

# SmartGen

MAKING CONTROL SMARTER

## HGM9420N\_HGM9420LT

### GENSET CONTROLLER

### USER MANUAL



郑州众智科技股份有限公司  
SMARTGEN(ZHENGZHOU)TECHNOLOGY CO.,LTD.

## SmartGen Registered trademark

No. 28 Xuemei Street, Zhengzhou, Henan, China

Tel: +86-371-67988888/67981888/67992951

+86-371-67981000 (overseas)

Fax: +86-371-67992952

Web: [www.smartgen.com.cn](http://www.smartgen.com.cn)

[www.smartgen.cn](http://www.smartgen.cn)

Email: [sales@smartgen.cn](mailto:sales@smartgen.cn)



All rights reserved. No part of this publication may be reproduced in any material form (including photocopying or storing in any medium by electronic means or other) without the written permission of the copyright holder.

SmartGen reserves the right to change the contents of this document without prior notice.

**Table 1 Software Version**

Date	Version	Note
2019-12-10	1.0	Original release.
2020-12-22	1.1	Optimize some details.
2021-12-16	1.2	Modify "Table 50 Order Model" in appendix.
2022-12-22	1.3	Update company logo and address information.
2023-05-19	1.4	Add HGM9420N-G and HGM9420LT-G.

**Table 2 Symbol Instruction**

Symbol	Instruction
 NOTE	Highlights an essential element of a procedure to ensure correctness.
 CAUTION	Indicates a procedure or practice, which, if not strictly observed, could result in damage or destruction of equipment.

SmartGen

# CONTENTS

1	OVERVIEW.....	6
2	PERFORMANCE AND CHARACTERISTICS.....	7
3	SPECIFICATION .....	10
4	OPERATION.....	12
4.1	INDICATOR LAMP .....	12
4.2	KEYS FUNCTION.....	13
4.3	LCD DISPLAY .....	14
4.3.1	MAIN DISPLAY.....	14
4.3.2	USER MENU AND PARAMETER SETTING.....	16
4.4	AUTO START/STOP OPERATION .....	18
4.4.1	ILLUSTRATION.....	18
4.4.2	AUTO START SEQUENCE.....	18
4.4.3	AUTO STOP SEQUENCE.....	19
4.5	MANUAL START/STOP OPERATION.....	19
5	CONTROLLER ATS CONTROL PROCEDURES .....	20
5.1	ATS CONTROL PROCEDURE FOR SYNC TRANSFER DISABLED .....	20
5.1.1	MANUAL TRANSFER PROCEDURE.....	20
5.1.2	AUTO TRANSFER PROCEDURE .....	20
5.2	ATS CONTROL PROCEDURE FOR SYNC TRANSFER ENABLED .....	21
5.2.1	MANUAL TRANSFER PROCEDURE.....	21
5.2.2	AUTO TRANSFER PROCEDURE .....	22
6	PROTECTIONS.....	26
6.1	WARNING ALARMS.....	26
6.2	BLOCK ALARMS .....	33
6.3	TRIP ALARMS .....	39
6.4	TRIP AND STOP ALARMS.....	45
6.5	SHUTDOWN ALARMS .....	51
7	WIRING CONNECTION.....	57
8	SCOPES AND DEFINITIONS OF PROGRAMMABLE PARAMETERS.....	60
8.1	CONTENTS AND SCOPES OF PARAMETERS.....	60
8.2	ENABLE DEFINITION OF DIGITAL OUTPUT PORTS 1-10.....	77
8.2.1	DEFINITION OF DIGITAL OUTPUT PORTS 1-10.....	77
8.2.2	DEFINED PERIOD OUTPUT.....	85
8.2.3	DEFINED COMBINATION OUTPUT .....	85
8.3	DEFINED CONTENTS OF DIGITAL INPUT PORTS 1-10.....	86
8.4	SELECTION OF SENSORS .....	89
8.5	CONDITIONS OF CRANK DISCONNECT SELECTION.....	90
9	PARAMETERS SETTING .....	91
10	CYCLE START .....	91
11	SENSOR SETTING.....	92

12	COMMISSIONING .....	93
13	TYPICAL APPLICATION .....	94
14	NEL TRIP DESCRIPTION.....	96
15	DUMMY LOAD CONNECTION .....	97
16	FUEL CONSUMPTION ILLUSTRATION .....	98
17	ETHERNET PORT .....	99
18	HOST USB PORT .....	100
19	INSTALLATION .....	101
19.1	SGE02 EXPANSION MODULE .....	101
19.1.1	4G ANTENNA PORT .....	101
19.1.2	GPS ANTENNA PORT .....	101
19.1.3	SIM CARD INSTALLATION .....	101
19.2	FIXING CLIPS .....	102
19.3	CASE DIMENSIONS AND CUTOUT SIZE .....	102
20	SMS MESSAGE ALARM AND REMOTE CONTROL .....	104
20.1	SMS MESSAGE ALARM.....	104
20.2	SMS MESSAGE REMOTE CONTROL.....	104
21	CONNECTIONS OF CONTROLLER AND J1939 ENGINE.....	106
21.1	CUMMINS ISB/ISBE .....	106
21.2	CUMMINS QSL9 .....	106
21.3	CUMMINS QSM11 (IMPORT) .....	107
21.4	CUMMINS QSX15-CM570 .....	107
21.5	CUMMINS GCS-MODBUS .....	108
21.6	CUMMINS QSM11.....	108
21.7	CUMMINS QSZ13.....	109
21.8	DETROIT DIESEL DDEC III/IV .....	109
21.9	DEUTZ EMR2 .....	110
21.10	JOHN DEERE.....	110
21.11	MTU MDEC.....	110
21.12	MTU ADEC (SMART MODULE) .....	111
21.13	MTU ADEC (SAM MODULE) .....	111
21.14	PERKINS .....	112
21.15	SCANIA .....	112
21.16	VOLVO EDC3 .....	112
21.17	VOLVO EDC4 .....	113
21.18	VOLVO-EMS2.....	113
21.19	YUCHAI .....	114
21.20	WEICHAI .....	114
22	FAULT FINDING .....	115
23	APPENDIX .....	116

## 1 OVERVIEW

**HGM9420N\_HGM9420LT** genset controller is used for automatic control of single genset to realize automatic start/AMF/synchronous transfer/cloud monitoring. This series of controller integrates digital, intelligent, and network technology. It fits with LCD graphic display, optional Chinese, English and other languages interface, and it is reliable and easy to use.

**HGM9420N\_HGM9420LT** genset controller applies 32-bit microprocessor technology, realizing precise measuring of many parameters, value adjusting, and timing, threshold adjusting etc. functions. A majority of parameters can be adjusted from the front panel. All parameters can be adjusted via USB or RS485 port or Ethernet on PC. Controller fits with SAE J1939 port, which can communicate with multiple ECU (ENGINE CONTROL UNIT) units with J1939. With compact structure, simple wiring, and high reliability, it can be used in various genset automation systems.

**HGM9420N\_HGM9420LT** genset controller can connect with SGE02-4G network communication expansion module, which can make genset connected with Internet. After controller is logged in cloud server, it can upload the data information (includes: GPS positioning site, altitude etc.) at real time to the corresponding cloud server. Users can monitor and check genset running status and event log at real time by mobile APP (IOS or Android), or PC similar terminal device. Network communication module has SMS message function.

## 2 PERFORMANCE AND CHARACTERISTICS

**HGM9420N\_HGM9420LT:** fits Mains-Gen power monitoring for Mains/Gen automatic transfer control (AMF). It is used for single unit automation system formed by one Mains and one Genset. Mains can be disabled by setting mains option parameters for single unit automation. By remote start signal genset auto start and stop can be controlled. Mains parameter display only can be realized by setting mains option parameters; by remote start signal genset auto start and stop can be controlled. Synchronous transfer function can be enabled to realize Gen and Mains synchronous transfer function.

Main characteristics are as below:

- 240x128 LCD with backlight, multilingual interface (including English, Chinese or other languages) which can be chosen at the site, making commissioning convenient for factory personnel; For other languages, language package needs to be written by PC software;
- Language packages include: Simplified Chinese, Traditional Chinese, English, Spanish, Portuguese, Russian, Arabic, Turkish, Thai, French, Polish, German, Italian, Dutch, Japanese, Korean;
- 2 RS485 and 1 RJ45 Ethernet communication port, "4 remotes" (remote control, remote measuring, remote communication, and remote adjusting) can be realized by MODBUS protocol;
- 1 Fn key, can be set to other key function on the panel, or Fn key function;
- Suitable for 3-phase 4-wire, 3-phase 3-wire, single phase 2-wire, and 2-phase 3-wire systems with voltage 120/240V and frequency 50/60Hz;
- Collects and shows 3-phase voltage of Mains/Gen, 3-phase current, frequency, load power and Gen voltage harmonic parameters;

### Mains

Wire voltage	Uab, Ubc, Uca
Phase voltage	Ua, Ub, Uc
Frequency	Hz
Phase sequence	

### Gen

Wire voltage	Uab, Ubc, Uca
Phase voltage	Ua, Ub, Uc
Frequency	Hz
Phase sequence	
Harmonic wave	1 <sup>st</sup> -21 <sup>st</sup> harmonic content      waveform distortion

### Load

Current	Ia, Ib, Ic
Each phase and total active power	P
Reactive power	Q
Apparent power	S
Power factor	PF
Gen total energy	kWh, kvarh, kVAh
Earth current	A
Unbalanced current	A

Load output percentage	(active power/rated power)x100%
Average load of current run	kW
Total energy of current run	kWh
Average load of last run	kW
Historical max average load	kW

— Mains has over voltage, under voltage, over frequency, under frequency, loss of phase, reverse phase sequence function; Gen has over voltage, under voltage, over frequency, under frequency, over current, over power, reverse power, loss of phase, reverse phase sequence, unbalanced voltage high, waveform distortion high, earth fault, unbalanced current high, power factor low, loss of excitation detection function;

— Synchronous transfer enabled parameters: voltage difference of Gen and Mains, frequency difference of Gen and Mains, phase angle difference of Gen and Mains;

— Collect precisely various parameters of engine:

Temperature	Unit: °C/°F
Oil pressure	Unit: kPa/psi/bar
Fuel Level	Unit: %
Speed	Unit: r/min (RPM)
Battery voltage	Unit: V
Charger D+ voltage	Unit: V
Total run time	max 65535 hours
Total start times	max 65535 times

— Control and protection function: automatic start/stop of the diesel genset, ATS (Auto Transfer Switch) control and perfect fault indication and protection function etc.;

— Parameter setting function: parameters can be modified by users and cannot be lost even in case of power outage; most of them can be adjusted from the front panel of the controller and all of them can be modified on PC by USB, RS485 port, or RJ45 Ethernet port;

— 3 fixed analog sensor inputs (temp., oil pressure, fuel level);

— 3 configurable sensors can be set to temp., pressure, or level sensor;

— Oil pressure sensor, level sensor, flexible sensor 1, flexible sensor 2 inputs can directly connect resistance, voltage, or current sensor; other sensor inputs only can connect resistance sensor; if need to connect voltage or current type sensors, please notify us before order;

— Multiple temp., pressure, and fuel level sensor curves can be used directly, and custom sensor curve can be done;

— Multiple crank disconnect conditions (speed, engine oil pressure, gen frequency) are optional;

— Wide power supply range DC (8~35)V, suitable for different starting battery voltage environment;

— Event log, real-time clock, scheduled start (start the genset once a day/week/month with load or not), scheduled stop (stop the genset at the set period per day/week/month) functions; cyclic start function of two gensets is fitted;

— Alarm data record function, which allows to record the genset data of 5 alarms;

- A USB Host port, where U flash of FAT32 format can be inserted, can put controller configured parameters to the controller, or save controller parameters to the U flash; Historical data can be saved;
- Accumulated run time of A and B and accumulated electric energy of A and B; Users can reset it as 0 and re-accumulate the value, making convenience for users to count the total value as they wish;
- Heater, cooler and fuel pump control functions;
- Applicable for water pump unit; it can also be used as an indicating instrument (only indication, alarm, no action for relays);
- Maintenance function; 3 groups of maintenance parameters, maintenance time, pre-alarm A time, pre-alarm B time, pre-alarm time due action, and maintenance time due action can be set;
- By judging DC voltage, auto charging start function can be realized;
- Through CAN (2) port or RS485 (2) port cycle start function of two gensets can be realized; master run time and backup run time can be set;
- Through CAN port, AIN24, AIN26-M02, AIN8, DIN16A and DOUT16B expansion module and BAC150CAN charger can be connected;
- By setting oil tank volume and oil consumption curve, residue fuel, residue run time and real-time oil consumption can be displayed;
- Monitoring data communication protocol address is customized by users;
- PLC function is fitted;
- By connecting SGE02-4G module, wireless network can connect with cloud server;
- By connecting SGE02-4G module, SMS function can be realized; when alarms occur, it can automatically send alarm information to the pre-set 5 phone numbers and also control genset and check genset status by messages;
- By connecting SGE02-4G module, GPS positioning function can be realized to obtain genset location;
- Genset data can be uploaded at changing by applying network data communication protocol of JSON format; at the same time network flow are extremely reduced by using compression algorithm; when alarms occur, it can immediately upload data to the server;
- IP65 waterproof level is achieved with the help of rubber-ring gasket between shell and control fascia;
- Metal fixing clips employed to fix the controller and make it perform better under high temperature environment;
- Modular structure design, flame-retardant ABS shell, pluggable terminal, built-in mounting, compact structure with easy installation.

3 SPECIFICATION

**Table 3 Technical Specification**

Item	Content
Working Voltage	Range: DC8V - DC35V continuous, DC reverse connection protection Resolution: 0.1V Accuracy: 1%
Overall Consumption	<7W (Standby mode: ≤2.5W)
AC Voltage	Phase voltage Range: AC15V - AC360V (ph-N) Resolution: 0.1V Accuracy: 0.5%
	Wire voltage Range: AC30V - AC620V (ph-ph) Resolution: 0.1V Accuracy: 0.5%
AC Frequency	Range: 5Hz - 75Hz Resolution: 0.01Hz Accuracy: 0.1Hz
AC Current	Rated: 5A Range: 0A - 10A Resolution: 0.1A Accuracy: 1%
Speed Sensor Voltage	Voltage Range: 1.0V - 24V (RMS) Frequency Range: 5Hz - 10000Hz
Charger(D+) Voltage	Range: DC0V - DC60V continuous Resolution: 0.1V Accuracy: 1%
DC Voltage	Range: DC0V - DC100V Resolution: 0.1V Accuracy: 1%
Analog Sensor	Resistor Input Range: 0Ω - 6000Ω Resolution: 0.1 Accuracy: 1Ω (below 300Ω)
	Voltage Input Range: 0V - 10V Resolution: 0.001V Accuracy: 1%
	Current Input Range: 0mA - 20mA Resolution: 0.01mA Accuracy: 1%
Crank Relay Output	16A 24V DC power supply output (relay output)
Fuel Relay Output	16A 24V DC power supply output (relay output)
Aux. Relay Output 1	16A 24V DC power supply output (relay output)

Item	Content
Aux. Relay Output 2	8A 24V DC power supply output (relay output)
Aux. Relay Output 3	8A 24V DC power supply output (relay output)
Aux. Relay Output 4	16A 250V AC volt-free output
Aux. Relay Output 5	16A 250V AC volt-free output
Aux. Relay Output 6	16A 250V AC volt-free output
Aux. Output 7-10	1A DC30V transistor B- output
Digital Input 1-10	Low threshold voltage 1.2V; high limit voltage is 60V;
RS485 port	Isolated, half-duplex, 9600 baud rate, maximum communication length 1000m
Internet Access	Self-adapting 10/100Mbit
CAN Port	Isolated, maximum communication length 250m, Belden 9841 cable or equivalent
EMC/CE Certification	EN 61326-1: 2013
Vibration Test	5 - 8 Hz: 17 mm 8 - 100 Hz: acceleration 4g 100 - 500Hz: acceleration 2g IEC 60068-2-6
Shock Test	50g, 11ms, half-sine, complete shock test from three directions, and 18 times shock for each test IEC 60068-2-27
Bump Test	25g, 16ms, half-sine IEC 60255-21-2
Production Compliance	According to EN 61010-1 installation category (over voltage category) III, 300V, pollution class 2, altitude 3000m
Case Dimensions	242mm x 186mm x 49mm
Panel Cutout	214mm x 160mm
Working Temperature	HGM9420N: (-25~+70)°C HGM9420LT: (-40~+70)°C
Working Humidity	(20~93)%RH
LCD Display (HGM9420LT)	Under the temperature of -40°C, after power on for 20s it can display normally; after power on for 2min, dynamic display responses normally.
Storage Temperature	HGM9420N: (-30~+80)°C HGM9420LT: (-45~+80)°C
Protection Level	Front Enclosure: IP65 when rubber-ring gasket is installed between the enclosure and the control screen Rear Enclosure: IP20
Insulation Intensity	Apply AC2.2kV voltage between high voltage terminal and low voltage terminal and the leakage current is not more than 3mA within 1min.
Weight	0.91kg

## 4 OPERATION

### 4.1 INDICATOR LAMP



**Fig.1 HGM9420N\_HGM9420LT Panel Indication**

**NOTE:** Description for parts of indicators.

**Table 4 Alarm Indicator Description**

Alarm Type	Alarm Indicator
Warning	Slow flashing (1 time per second)
Block	Slow flashing (1 time per second)
Trip	Fast flashing (5 times per second)
Trip and Stop	Fast flashing (5 times per second)
Shutdown	Fast flashing (5 times per second)
No Alarm	Extinguished

**NOTE 1:** Running indicator: is normally illuminated after crank disconnection and before ETS stop and extinguished for other periods;

**NOTE 2:** Gen normal indicator: is normally illuminated when the generator is normal; flashing when generator state is abnormal; extinguished when there is no generating power.













**NOTE 3:** Mains normal indicator: is always illuminated when mains is normal, flashing when mains is abnormal, extinguished when there is no mains.



**NOTE 4:** Fn function key indicator: is illuminated when Fn function key is pressed, extinguished when group keys are pressed.

**NOTE 5:** When mains disabled, mains normal indicator is extinguished, meanwhile mains close/open key won't work.

## 4.2 KEYS FUNCTION





**Table 5 Keys Function Description**

Icons	Keys	Description
	Stop Key	Stop the running generator in Auto/Manual mode; Reset alarm in stop mode; Press for over 3s, panel indicators can be tested (lamp test); During stop process, press this key again to stop the generator immediately.
	Start Key	Start the static genset in Manual mode; During start process, press this key again can enter the next phase quickly.
	Manual Key	Press this key and the controller goes in Manual mode.
	Auto Key	Press this key and controller goes in Auto mode.
	Mute/ Reset Alarm Key	Remove the alarm sound; Remove the alarm by pressing for over 3s.
	Fn Key	Combine with other key to make shortcut setting; It can also be set to other function key (start key, stop key etc.).
	Close/Open Key	Close/open Gen or Mains breaker in manual mode.
	Up/Increase Key	1) Screen scroll; 2) Move up the cursor and increase value in setting menu.
	Down/Decrease Key	1) Screen scroll; 2) Move down the cursor and decrease value in setting menu.
	Left Key	1) Page scroll; 2) Left move the cursor in setting menu.
	Right Key	1) Page scroll; 2) Right move the cursor in setting menu.
	Set/Confirm Key	1) Enter setting screen; 2) Enter next menu in setting or confirm the settings.
	Exit Key	1) Return to main menu; 2) Return to previous menu in setting.

**NOTE:** Press  and  simultaneously in manual mode and it can force the generator to crank. At this time the controller shall not judge whether the genset start is successful or not according to the starting conditions. It is

controlled by the operator. When operator observes that the genset has started, he/she should release the key and the start output will be deactivated. Safety on delay will be initiated.





**NOTE:** Regarding ECU genset, in Stop/Auto mode, Press  key and it shall power on the ECU (fuel output and ECU power output are active.).

**NOTE:** Fn key and other keys combination function. When engine type is NTSC1, press  and  simultaneously, engine target speed will increase 50 turns; press  and  simultaneously, engine target speed will decrease 50 turns.

**CAUTION:** Factory default password is "00318", and users can change it in case others change the advanced parameter settings. Please clearly remember the password after changing. If you forget it, please contact SmartGen services and send the PD information in the controller page of "ABOUT" to the service personnel.

## 4.3 LCD DISPLAY

### 4.3.1 MAIN DISPLAY

Paging is applied for the main screen;   is used for page scroll and   for screen scroll.

**Main Screen** includes the following contents:

Gen: voltage, frequency, current, active power, reactive power;

Mains: voltage;

Engine: speed, temperature, engine oil pressure, liquid level, battery voltage;

Part of status displays.

**Status** page includes the following contents:

SGE02-4G status, genset status, Mains status, and breaker status.

**Engine** page includes the following contents:

Engine speed, engine temperature, engine oil pressure, fuel level, battery voltage, charger voltage, accumulated running time, accumulated start times, DC voltage.

**NOTE:** If CAN BUS is connected and engine information is from J1939, this page also includes: coolant pressure, coolant level, fuel temperature, fuel pressure, inlet temperature, exhaust temperature, turbo pressure, fuel consumption, total fuel consumption and so on. (Different engines have different parameters.)

**NOTE:** If AIN24 expansion module, or AIN16-M02 expansion module, or BAC150CAN expansion module is enabled, engine page also displays related monitoring data of expansion module.

**NOTE:** If oil tank volume and oil consumption setting are enabled, engine page also displays residue fuel, residue running time of fuel, and oil consumption parameters.

**NOTE:** If flexible sensor 1, flexible sensor 2, and flexible sensor 3 are enabled, engine page also displays the data of flexible sensor 1, flexible sensor 2, and flexible sensor 3.

**Gen** page includes the following contents:

Phase voltage, wire voltage, frequency, phase sequence.

**NOTE:** If harmonic display is enabled, gen page also displays harmonic content, voltage unbalance percentage.

**Load** page includes the following contents:

Load current, active power of different phases, total active power and percentage, reactive power of different phases, total reactive power, apparent power of different phases, total apparent power, power factor of different phases, average power factor, accumulated active electric energy, accumulated

reactive electric energy, accumulated apparent electric energy, earth current and percentage, unbalanced current and percentage, average load of this run, historical max average load, average load of last run, accumulated electric energy of this run.

**▲NOTE:** P stands for active power; Q stands for reactive power;

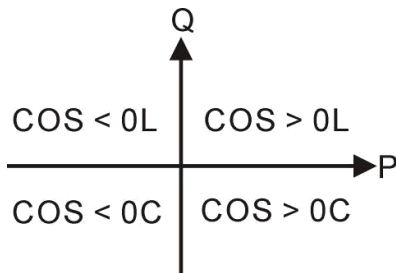

**Table 6 Power Factor Display Description**

Power Factor	Conditions	Active Power	Reactive Power	Remark
COS>0L	P>0, Q>0	Input	Input	Load is resistive induction.
COS>0C	P>0, Q<0	Input	Output	Load is resistive capacitance.
COS<0L	P<0, Q>0	Output	Input	Load equals an under excitation generator.
COS<0C	P<0, Q<0	Output	Output	Load equals an over excitation generator.

**▲NOTES:**

1. Input active power, and generator sends electricity to load.
2. Output active power, and load supplies electricity to generator.
3. Input reactive power, and generator sends reactive power to load.
4. Output reactive power, and load sends reactive power to generator.

**Mains** page includes the following contents:

Phase voltage, wire voltage, frequency, phase sequence.

**Sync.** page includes the following contents:

**▲NOTE:** This displays when Sync. Transfer is enabled.

Voltage difference, frequency difference, phase difference.

**Alarm** page includes the following contents:

**▲NOTE:** For ECU alarms and shutdown alarms, if the detailed alarm information is displayed, check the engine according to it. Otherwise, please check the engine manual according to SPN alarm code.

**Event log** page includes the following contents:

Records about all start/stop events (alarm events except warnings, manual start/stop events) and the real time when events occur.

**Maintenance Countdown** page includes the following contents:

3 maintenance countdowns display.

**▲NOTE:** If 3 maintenance countdowns are not enabled, they are not displayed.

**Others** page includes the following:

Module date and time, input and output port status, communication indication, RS485 configuration, Ethernet configuration (if enabled), LCD temperature, MCU temperature.

**NOTE:** HGM9420N controller LCD temperature is +++°C.

**About** page includes the following contents:

Release software version, hardware version, and product PD number.

## 4.3.2 USER MENU AND PARAMETER SETTING

Press  key for more than 1s and it enters user menu.

- Parameter Setting

After inputting the correct password (factory default is 00318) you can enter the parameter setting screen.

- Language

Optional Simplified Chinese, English and others.

- Commissioning

On load, off load and users-defined commissioning are optional. Defined commissioning can be configured regarding load on or load off, commissioning time, and which mode it shall return after commissioning (manual mode, auto mode and stop mode).

- U Flash Configurations Writing and Reading

Configuration files in U flash can be checked; loading configuration files, saving configuration files, saving new configuration files, configuration files can also be saved and loaded on PC; configuration file suffix name is “.lgm”.





- Clear users' accumulation





It can clear accumulated running time A and B, accumulated electric energy A and B.



Parameter settings include following contents:







- ◇ Module setting
- ◇ Mains setting
- ◇ Timers setting
- ◇ Engine setting
- ◇ Generator setting
- ◇ Load setting
- ◇ ATS setting
- ◇ Analog sensor setting
- ◇ Digital input setting
- ◇ Digital output setting
- ◇ Scheduled run setting
- ◇ Scheduled not run setting
- ◇ Maintenance setting
- ◇ Alt. config setting
- ◇ Master-slave cycle start setting
- ◇ Sync. setting
- ◇ Expansion setting

For example:

Return	Start Delay	<b>Set Menu 1:</b>   is used to change the contents needed to set;  is used to enter the setting (Set Menu 2);  is used to exit from setting.
Module	Stop Delay	
Mains	Pre-heat Delay	
<b>Timers</b>	Fuel Delay	
Engine	Cranking Time	
Generator	Crank Rest Time	
Load	Safety On Time	
Switch	Start Idle Time	
Analog Sensor	Warming Up Time	
Digital Input	Cooling Time	

Start Delay	00030s	<b>Set Menu 2:</b>   is used to change the contents needed to set;  is used to confirm the setting (Set Menu 3),  returns to previous menu (Set Menu 1).
<b>Stop Delay</b>		
Pre-heat Delay		
Fuel Delay		
Cranking Time		
Crank Rest Time		
Safety On Time		
Start Idle Time		
Warming Up Time		
Cooling Time		

Start Delay	00030s	<b>Set Menu 3:</b>  is used to enter the setting (Set Menu 4),  is used to return to previous menu (Set Menu 2).
<b>Stop Delay</b>		
Pre-heat Delay		
Fuel Delay		
Cranking Time		
Crank Rest Time		
Safety On Time		
Start Idle Time		
Warming Up Time		
Cooling Time		

Start Delay	00030s	<b>Set Menu 4:</b>   is used to change cursor position;   is used to change the value where the cursor is;  is used to confirm the setting (Set Menu 3),  is used to exit the setting (Set Menu 3).
<b>Stop Delay</b>		
Pre-heat Delay		
Fuel Delay		
Cranking Time		
Crank Rest Time		
Safety On Time		
Start Idle Time		
Warming Up Time		
Cooling Time		

**NOTE:** At configuration, press  and it can directly exit from the setting.

## 4.4 AUTO START/STOP OPERATION

### 4.4.1 ILLUSTRATION

Press  key and the indicator beside is illuminated, which means the genset is at Auto Start Mode.

### 4.4.2 AUTO START SEQUENCE

a) HGM9420N\_HGM9420LT start conditions:

**Mains enabled:** when Mains is abnormal (over voltage, under voltage, over frequency, under frequency, loss of phase, reverse phase sequence), controller enters “Mains abnormal delay”, LCD mains status line displays countdown. When Mains abnormal delay is over, it enters “start delay”; or when remote start (on load) input is active, it enters “start delay”.

**Mains disabled or Mains only displayed:** when remote start (on load) input is active, it enters “start delay”.





- b) “Start delay” countdown will be displayed on genset status line;
- c) When start delay is over, preheating relay is energized (if configured), “preheat delay XX s” information will be displayed on status line;
- d) After the above delay, the fuel relay is energized, and then the starting relay is engaged. During the “start time”, if the genset does not start, then fuel relay and starting relay stop outputting, and enters “crank rest time”, waiting for next crank;
- e) Should the start continue beyond the set attempts, the controller issues “start failure” and stops the genset and at the same time alarm page on LCD displays “start failure alarm”;
- f) If it starts during the attempts, it enters “safety on time”, and during this period Low Oil Pressure, High Temperature, Under speed and Charge Alternator Failure alarms are all inactive; After “safety on time”, it enters “start idle delay” (if configured);
- g) During “start idle delay”, under speed, under frequency, under voltage alarms are inhibited. When this delay is over, “warming up delay” is initiated (if configured);
- h) When synchronous transfer is disabled, mains abnormal start or remote start (on load) input is active, and when warming up delay is over, if gen is normal, gen status indicator is illuminated; if gens voltage, frequency meet the on-load requirements, gen close relay outputs and genset takes the load. Gen supply indicator is illuminated, and genset enters normal running status; if genset voltage or frequency is abnormal, controller issues alarm and shutdowns (LCD alarm page displays gen alarm type);
- i) When synchronous transfer is enabled, mains is normal and remote start (on load) input is active, when warming up delay is over, if gen is normal, then gen status indicator is illuminated. Controller issues close signal after waiting for genset and mains meeting the sync. requirement; after controller detects gen close feedback, it immediately issues mains open signal, and genset takes the load;
- j) When synchronous transfer is enabled, mains abnormal start, and warming up delay is over, if gen is normal, gen status indicator is illuminated; if genset voltage, frequency is up to the load requirement, then gen close relay outputs, and genset takes the load. Gen supply indicator is illuminated and genset enters normal running status.

**▲NOTE:** When Remote Start is applied to start (Off Load), the procedure is the same as above. Only when it is in procedure h) or i), generator close relay is deactivated, and moreover, genset is off load.

## 4.4.3 AUTO STOP SEQUENCE

- a) In the process of genset normal running, if mains recovers, genset enters "Mains voltage normal delay". When Mains normal is confirmed, Mains status indicator is illuminated and "stop delay" is initiated. Or when remote start input is inactive, "stop delay" is initiated;
- b) After stop delay is over:
  - 1) **Synchronous Transfer Disabled:** Cooling Time is initiated, and at the same time gen close relay is disconnected; after "switch transfer delay", Mains close relay outputs and Mains takes the load; Gen supply indicator is extinguished and Mains supply indicator is illuminated;
  - 2) **Synchronous Transfer Enabled:** Controller issues Mains close signal after waiting for genset and Mains meeting sync. requirement; when Mains close feedback signal is detected, it immediately issues Gen open signal; Gen supply indicator is extinguished, and Mains takes the load; Mains supply indicator is illuminated and Cooling Time is initiated;
- c) At entering "stop idle delay" (if configured), the idling speed relay is energized;
- d) "ETS solenoid hold" begins, ETS relay is energized while fuel relay is de-energized, and complete stop is detected automatically;
- e) "Fail to stop delay" begins, and complete stop is detected automatically;
- f) When generator stops completely, "after stop delay" will be initiated. Otherwise, controller enters "fail to stop" period, and issues failed to stop alarm (If generator stops successfully after "fail to stop" alarm has initiated, "after stop delay" will be initiated and the alarm will automatically be removed.);
- g) Generator is placed into its standby mode after its "after stop delay";

## 4.5 MANUAL START/STOP OPERATION





- a) HGM9420N\_HGM9420LT: Manual mode is selected by pressing the  key; a LED beside it will be illuminated to confirm the operation; then press  key to start the gen-set; it can detect crank disconnect condition and generator accelerates to high-speed running automatically. With high temperature, low oil pressure, over speed and abnormal voltage during generator running, controller can protect genset to stop quickly (please refer to c-i of **4.4.2 Automatic Start Sequence** for detailed procedures). Load breaker can't transfer automatically in manual mode, load breaker close/open can be realized by manually pressing   key.
- b) MANUAL STOP: Press  and it can shut down the running generators. (Please refer to b-g of **4.4.3 Automatic Start Sequence** for detailed procedures).



## 5 CONTROLLER ATS CONTROL PROCEDURES





### 5.1 ATS CONTROL PROCEDURE FOR SYNC TRANSFER DISABLED

#### 5.1.1 MANUAL TRANSFER PROCEDURE

When controller is in **Manual** mode, the switch control procedures will start through manual transfer procedures. Users can control the loading transfer of ATS via pressing breaker close/open keys.

**Mains Enabled:** If open detection is disabled, press gen close/open key  ; if gen takes the load, then switch open outputs; if load is disconnected, then gen closes; if Mains takes the load, then mains opens; when open delay is over, gen closes. Press mains close/open key  , if mains takes the load, then switch open outputs; if load is disconnected, then Mains closes; if Gen takes the load, then gen opens; when open delay is over, Mains closes.

If open detection is enabled and Mains taking load transfers to Gen taking load, first press Mains open key  , after open delay, press Gen close key, and Gen closes (directly press Gen close key, no action). If Gen loading transfers to Mains loading, the same procedure as above;

**Mains Disabled:** Press Gen close/open key  , if Gen doesn't take the load, then Gen close outputs. Press Gen close/open key  , if Gen takes the load, then Gen open outputs.

#### 5.1.2 AUTO TRANSFER PROCEDURE

When controller is in Auto or Stop mode, the switch control procedure is automatic control procedure.

a) If input configuration is close status auxiliary input:

**Mains Enabled:**

- If open detection is enabled and Mains loading transfers to Gen loading, after open delay and transfer interval delay, failed to transfer starts to detect at the same time of open output. After detection time is due, if it fails to open, then Gen won't close; otherwise Gen closes. At the same time of Gen close, failed to transfer starts to detect. After detection time is due, if it fails to close, then wait for gen close. If failed to transfer warning is enabled, close/open failure will issue warning signal. About Gen loading transferring to Mains loading, the same is as above.
- If open detection is disabled and Mains loading transfers to Gen loading, after open delay and transfer interval delay, Gen closes. At the same time of gen close, failed to transfer starts to detect. After detection time is due, if it fails to close, then wait for gen close; if failed to transfer warning is enabled, warning signal will be issued. About Gen loading transferring to Mains loading, the same is as above.

**Mains Disabled**

- When open detection is enabled, gen on-load changes to gen off-load. After open delay in the process of open output, transfer failure is detected. When the detection time is due, if open fails, then open is waited for, otherwise open is completed. For generator off-load changing to generator

on-load, after close delay, in the process of close output, transfer failure is detected. When the detection time is due, if close fails, then close is waited for, otherwise close is completed.

- If transfer failure warning is enabled, then open/close failures shall issue warning signals.
- When open detection is disabled, generator on-load changes to generator off-load. After open delay, open is completed. For generator off-load changing to generator on-load, after close delay, in the process of close output, transfer failure is detected. When the detection time is due, if close fails, then close is waited for, otherwise close is completed. If transfer failure warning is enabled, then close failure shall issue warning signal.

b) In case input port is not configured as close status auxiliary input:

### **Mains Enabled:**

For mains on-load changing to generator on-load, after open delay and transfer rest delay, generator close occurs. For generator on-load changing to mains on-load, it is the same as above.

### **Mains Disabled:**

For generator off-load changing to generator on-load, generator close outputs. For generator on-load changing to generator off-load, generator open outputs.

**NOTE 1:** In case of applying ATS without neutral breaking, open detection shall be disabled.

**NOTE 2:** In case of applying ATS with neutral breaking, open detection can be enabled and disabled. If it is enabled, please configure open output.

**NOTE 3:** In case of applying AC contactor, open detection is recommended to be enabled.

## **5.2 ATS CONTROL PROCEDURE FOR SYNCHRONOUS TRANSFER ENABLED**

### **5.2.1 MANUAL TRANSFER PROCEDURE**



Breaker is switched by manual control if controller is in manual mode.



Operator controls ATS load transfer via C/O key.

### **Mains Enabled:**



Press Gen close/open key   :

1. In case of generator on-load, then generator open outputs;
2. In case of generator&mains off-load, then generator close occurs;
3. In case of mains on-load, when generator synchronization close is over, mains open occurs and generator is on-load.



**NOTE:** In the process of waiting for synchronization or if synchronization fails, press mains C/O key   to cancel synchronization, and mains breaker is open. Then press gen C/O key to force gen take load.

Press Mains Close/Open key   :

1. In case of gen on-load, then mains open outputs;
2. In case of mains/gen both off-load, then mains close occurs;
3. In case of gen on-load, then mains synchronization close is over, gen open occurs and mains is on-load.

**NOTE:** In the process of waiting for synchronization or if synchronization fails, press generator C/O key   to cancel synchronization, and generator breaker is open. Then press mains C/O key to force mains take load.

### **Mains Disabled:**

Press Gen C/O key  , and if generator is off-load, then generator close outputs; if generator is on-load, then generator open outputs.

## 5.2.2 AUTO TRANSFER PROCEDURE

Breaker is switched by automatic control if controller in auto or stop mode.

### **Mains Enabled:**

1. For mains on-load changing to generator on-load,  
Generator close outputs when genset and mains meet synchronization conditions. When the controller detects generator close feedback signal, mains open outputs and generator is on-load. If generator close is outputted, generator close feedback signal is not detected during the C/O synchronization period, generator open is outputted and mains is on-load. Mains open status is detected at the time of mains open output. When the C/O synchronization time is due, if mains open fails, generator open outputs. If synchronization signal is not detected during the set synchronization failure time, then synchronization failure alarm is issued. If synchronization failure alarm is warning and transfer is forced to be enabled after synchronization failure, then mains open outputs. After open delay, mains open status is detected at the time of mains open output. When detection time is due, if mains open fails, then generator shall not close, otherwise, after transfer delay generator close outputs. Generator close status is detected at the time of generator close output. When the detection time is due, if generator close fails generator close is waited for. Transfer procedure is as below:

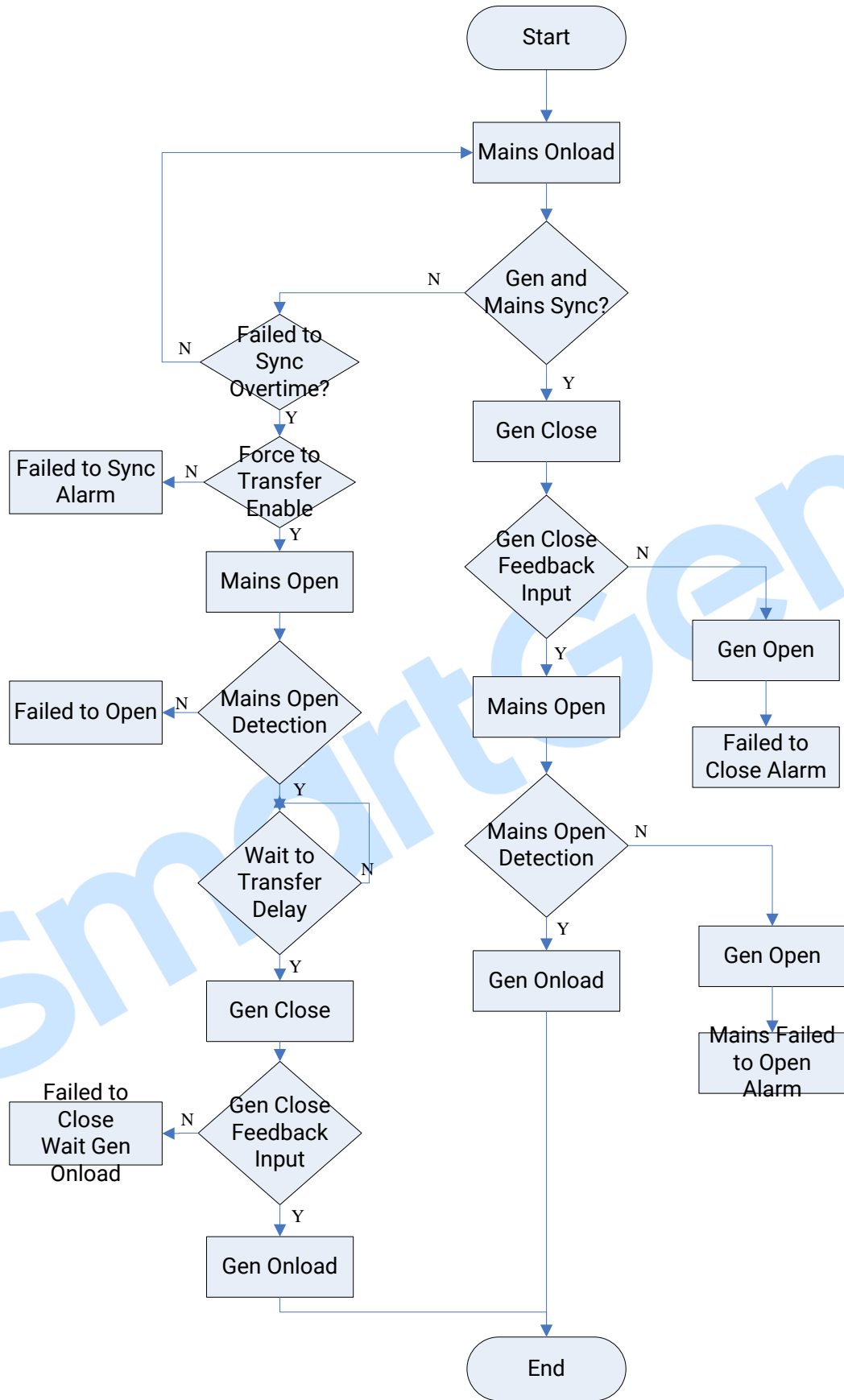

Fig. 2 Mains Onload Transferring to Gen Onload

2. For gen on-load changing to mains on-load,

Mains close outputs when genset and mains meet synchronization conditions. When the controller detects mains close feedback signal, generator open outputs and mains is on-load. If mains close is outputted, mains close feedback signal is not detected during the C/O synchronization period, mains open is outputted and generator is on-load. Generator open status is detected at the time of generator open output. When the C/O synchronization time is due, if generator open fails, mains open outputs. If synchronization signal is not detected during the set synchronization failure time, then synchronization failure alarm is issued. If synchronization failure alarm is warning and transfer is forced to be enabled after synchronization failure, then generator open outputs. After open delay, generator open status is detected at the time of generator open output. When detection time is due, if generator open fails, then mains shall not close, otherwise, after transfer delay mains close outputs. Mains close status is detected at the time of mains close output. When the detection time is due, if mains close fails mains close is waited for. Transfer procedure is as below:

SmartGen

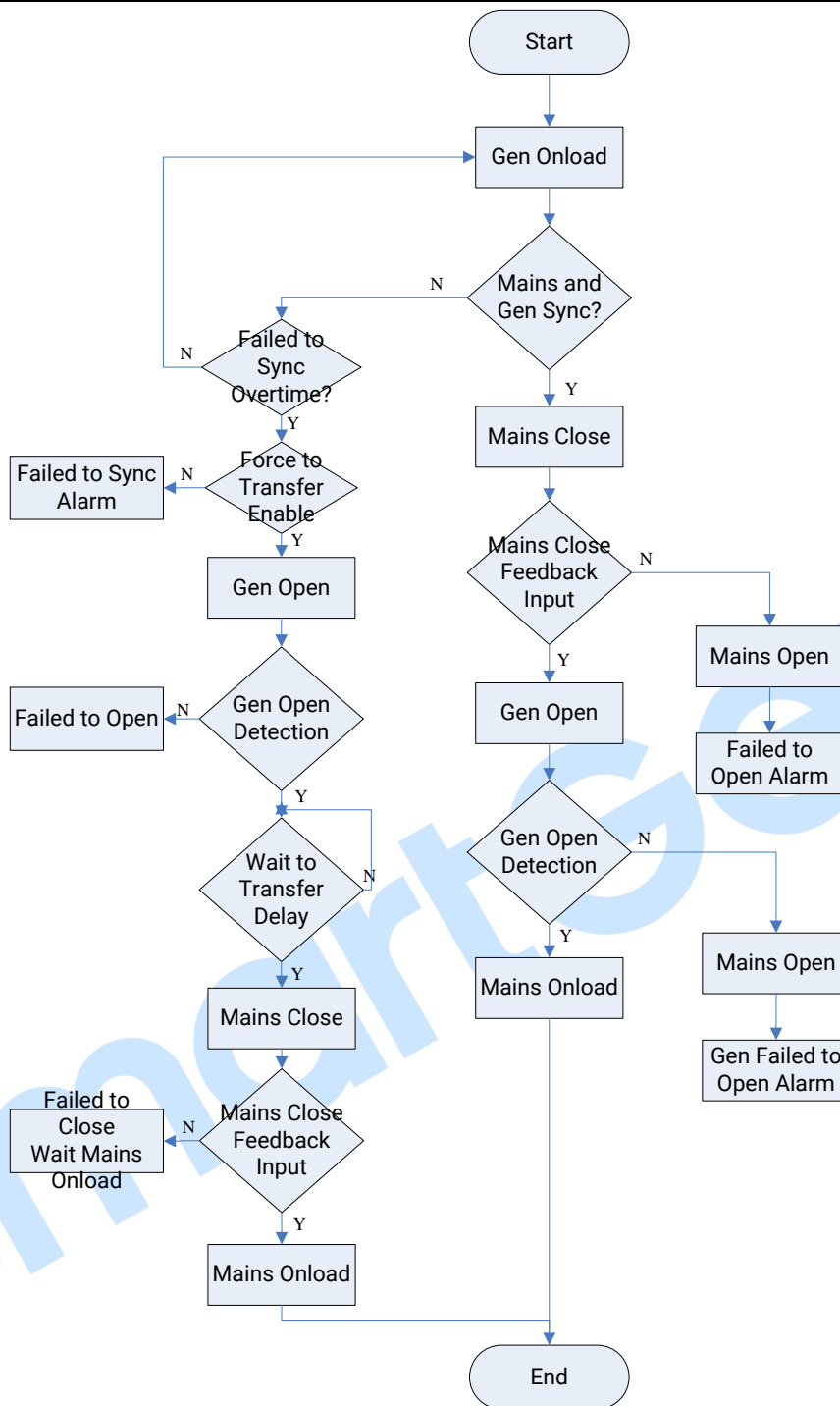



Fig. 3 Gen Onload Transferring to Mains Onload

**Mains Disabled:**

For generator off-load changing to generator on-load, generator close outputs. For generator on-load changing to generator off-load, generator open outputs.

**NOTE 1:** Mains close status and Generator close status are needed to be configured for input port, otherwise controller shall issue mains breaker failure warning or generator breaker failure warning.

**NOTE 2:** For synchronization failure alarm, it is needed to press  longer to remove the alarm.

**NOTE 3:** If synchronization C/O detection time is less than breaker C/O time, then synchronization C/O detection time is breaker C/O time.

6 PROTECTIONS

6.1 WARNING ALARMS

When controller detects the warning alarm, it only issues warning, and the genset does not open and shut down. When the warning signal disappears, alarm reset automatically.

Table 7 Warning Alarms

No	Type	Description
1	Over Speed	When this is enabled, and the controller detects that the genset speed is above the pre-set limit, it will initiate a warning. It is always detected.
2	Under Speed	When this is enabled and the controller detects that the genset speed is below the pre-set limit, it will initiate a warning. It is detected after "warming up" and before "stop idle".
3	Loss of Speed Signal	When the controller detects the engine speed is 0, it shall issue a warning. It is detected after "safety on time" before "ETS solenoid hold".
4	Gen Over Frequency	When this is enabled, and the controller detects the frequency is above the preset limit, it shall issue a warning. It is detected always.
5	Gen Under Frequency	When this is enabled, and the controller detects the frequency is below the preset limit, it shall issue a warning. It is detected after "warming up" before "stop idle".
6	Gen Over Voltage	When this is enabled, and the controller detects the voltage is above the preset limit, it shall issue a warning. It is always detected.
7	Gen Under Voltage	When this is enabled, and the controller detects the voltage is below the preset limit, it shall issue a warning. It is detected after "warming up" before "stop idle".
8	Gen Over Current	When this is enabled, and the controller detects the current is above the preset limit, it shall issue a warning. It is always detected.
9	Unbalanced Current	When this is enabled, and the controller detects the value is above the preset limit, it shall issue a warning. It is always detected.
10	Earth Fault	When this is enabled, and the controller detects the earth current is above the preset limit, it shall issue a warning. It is always detected.
11	Reverse Power	When this is enabled, and the controller detects the reverse power (negative) is above the preset limit, it shall issue a warning. It is always detected.
12	Over Power	When this is enabled, and the controller detects the genset power

No	Type	Description
		(positive) is above the preset limit, it shall issue a warning. It is always detected.
13	Loss Excitation Fault	When this is enabled, and the controller detects the genset reactive power (negative) is above the preset limit, it shall issue a warning. It is always detected.
14	ECU Alarm	When the controller receives the engine alarm signal from J1939, it shall issue a warning. It is always detected.
15	Temp. Sensor Open	When the controller detects the sensor circuit is open, it shall issue a warning. It is always detected.
16	Engine Temp High	When this is enabled, and the controller detects the temp. is above the preset limit, it shall issue a warning. It is detected after "safety on time" before "ETS solenoid hold".
17	Engine Temp Low	When this is enabled, and the controller detects the temp. is below the preset limit, it shall issue a warning. It is detected after "safety on time" before "ETS solenoid hold".
18	Oil Pressure Sensor Open	When the controller detects the sensor circuit is open, it shall issue a warning. It is always detected.
19	Oil Pressure Low	When this is enabled, and the controller detects the pressure is below the preset limit, it shall issue a warning. It is detected after "safety on time" before "ETS solenoid hold".
20	Oil Pressure Sensor Wrong	When voltage or current input is selected for the curve type of the controller, and the controller detects input signal is abnormal, it shall issue a warning, and meanwhile the curve is transferred to resistance type to prevent damaging the controller. It is detected always.
21	Fuel Level Sensor Open	When the controller detects the sensor circuit is open, it shall issue a warning. It is always detected.
22	Fuel Level Low	When this is enabled, and the controller detects the level is below the preset limit, it shall issue a warning. It is always detected.
23	Fuel Level Sensor Wrong	When voltage or current input is selected for the curve type of the controller, and the controller detects input signal is abnormal, it will issue a warning signal; meanwhile curve type will transfer to resistance type to prevent damaging the controller. It is always detected.
24	Flex. Sensor 1 Open	When controller detects sensor is open, it will issue a warning signal; It is always detected.
25	Flex. Sensor 1 High	When over high warning is enabled, and the controller detects the sensor value is above the preset upper limit, it shall issue a warning.

No	Type	Description
		It is detected after "safety on time" before "ETS solenoid hold" when the sensor is selected as temperature sensor and pressure sensor; It is always detected when the sensor is selected as fuel level sensor.
26	Flex. Sensor 1 Low	When over low warning is enabled, and the controller detects the sensor value is below the preset low limit, it shall issue a warning. It is detected after "safety on time" before "ETS solenoid hold" when the sensor is selected as temperature sensor and pressure sensor; It is always detected when the sensor is selected as fuel level sensor.
27	Flex. Sensor 1 Wrong	When voltage or current input is selected for the curve type of the controller, and the controller detects input signal is abnormal, it shall issue a warning, and meanwhile the curve is transferred to resistance type to prevent damaging the controller. It is detected always.
28	Flex. Sensor 2 Open	When the controller detects the sensor circuit is open, it shall issue a warning. It is always detected.
29	Flex. Sensor 2 High	When over high warning is enabled, and the controller detects the sensor value is above the preset upper limit, it shall issue a warning. It is detected after "safety on time" before "ETS solenoid hold" when the sensor is selected as temperature sensor and pressure sensor; It is always detected when the sensor is selected as fuel level sensor.
30	Flex. Sensor 2 Low	When over low warning is enabled, and the controller detects the sensor value is below the preset low limit, it shall issue a warning. It is detected after "safety on time" before "ETS solenoid hold" when the sensor is selected as temperature sensor and pressure sensor; It is always detected when the sensor is selected as fuel level sensor.
31	Flex. Sensor 2 Wrong	When voltage or current input is selected for the curve type of the controller, and the controller detects input signal is abnormal, it shall issue a warning, and meanwhile the curve is transferred to resistance type to prevent damaging the controller. It is detected always.
32	Flex. Sensor 3 Open	When the controller detects the sensor circuit is open, it shall issue a warning. It is always detected.
33	Flex. Sensor 3 High	When over high warning is enabled, and the controller detects the sensor value is above the preset upper limit, it shall issue a warning. It is detected after "safety on time" before "ETS solenoid hold" when the sensor is selected as temperature sensor and pressure sensor; It is always detected when the sensor is selected as fuel level sensor.
34	Flex. Sensor 3 Low	When over low warning is enabled, and the controller detects the sensor value is below the preset low limit, it shall issue a warning. It is detected after "safety on time" before "ETS solenoid hold" when the sensor is selected as temperature sensor and pressure sensor;

No	Type	Description
		It is always detected when the sensor is selected as fuel level sensor.
35	Fail to Stop	After "fail to stop delay" is over, if the genset does not stop completely, it will initiate a warning alarm.
36	Charge Alternator Failure	When this is enabled and the controller detects that charger voltage is below the pre-set limit, it will initiate a warning alarm. It is detected when the genset is normally running.
37	Battery Over Volt	When this is enabled, and the controller detects the battery voltage is above the preset limit, it shall issue a warning signal. It is always detected.
38	Battery Under Volt	When this is enabled, and the controller detects the battery voltage is below the preset limit, it shall issue a warning signal. It is always detected.
39	Fail to Sync.	If the controller doesn't detect sync. signal within the pre-set time, it will initiate a warning alarm. It is detected when breaker closes.
40	Gen Breaker Alarm	When Sync. transfer is enabled, and when gen close status input is not set for controller input port, the controller will initiate a warning alarm. It is always detected.
41	Mains C/O Alarm	When Sync. transfer is enabled, and when mains close status input is not set for controller input port, the controller will initiate a warning alarm. It is always detected.
42	Maintenance Time 1 Due	Maintenance 1 enabled, when maintenance 1 countdown is equal to maintenance 1 countdown A or maintenance 1 countdown B, or maintenance 1 countdown is 0, controller will issue a warning signal. It is detected when genset is running.
43	Maintenance Time 2 Due	Maintenance 2 enabled, when maintenance 2 countdown is equal to maintenance 2 countdown A or maintenance 2 countdown B, or maintenance 2 countdown is 0, controller will issue a warning signal; It is detected when genset is running.
44	Maintenance Time 3 Due	Maintenance 3 enabled, when maintenance 3 countdown is equal to maintenance 3 countdown A or maintenance 3 countdown B, or maintenance 3 countdown is 0, controller will issue a warning signal; It is detected when genset is running.
45	Gen Reverse Phase Sequence	When controller detects gen reverse phase sequence, controller issues a warning signal. Gen reverse phase sequence detection enabled, it is detected when 3P4W or 2P3W phase voltage is over 30V, 3P3W wire voltage is over 50V.
46	Gen Loss of Phase	When controller detects gen loss of phase, controller issues a warning signal; Gen loss of phase enabled, it is detected when 3P4W or 2P3W phase voltage is above 30V, or 3P3W wire voltage is above 50V.

No	Type	Description
47	Switch Failure	When controller detects switch close/open failure and switch failure warning is enabled, controller issues a warning signal.
48	Digital Input Alarm	When digital input port is selected to user defined and it is active, controller issues related input alarm signal; It is detected in the detection range of input port settings.
49	PLC Function Alarm	When PLC function selects user defined and it is active, controller issues related PLC function alarm signal. It is detected in the detection range of PLC function settings.
50	DIN16 Comm. Fail	When DIN16 communication is enabled and the controller cannot receive the communication data, it will initiate a warning. It is always detected.
51	DIN16 Input Alarm	When DIN16 input is set users-defined and if it is active, the controller will initiate a warning. It is detected in the detection range set in the input.
52	DOUT16 Comm. Fail	When DOUT16 communication is enabled and the controller cannot receive the communication data, it will initiate a warning. It is always detected.
53	AIN24 Comm. Fail	When AIN24 communication is enabled and the controller cannot receive the communication data of AIN24, it will initiate a warning. It is always detected.
54	AIN24 Cylinder Temp. High	When this is enabled and the controller detects cylinder temperature has exceeded the pre-set value, it will initiate a warning alarm. It is detected after "safety on time" before "ETS solenoid hold".
55	AIN24 Exhaust Temp. High	When this is enabled and the controller detects exhaust temperature has exceeded the pre-set value, it will initiate a warning alarm. It is detected after "safety on time" before "ETS solenoid hold".
56	AIN24 Cylinder Temp. Difference High	When this is enabled and the controller detects cylinder temp. difference has exceeded the pre-set value, it will initiate a warning alarm. It is detected after "safety on time" before "ETS solenoid hold".
57	AIN24 Sensor Open	When the controller detects the sensor circuit is open, it shall issue a warning. It is always detected.
58	AIN24 Sensor High	When over high warning is enabled, and the controller detects the sensor value is above the preset upper limit, it shall issue a warning. It is detected after "safety on time" before "ETS solenoid hold" when the sensor is selected as temperature sensor and pressure sensor; It is always detected when the sensor is selected as fuel level sensor.
59	AIN24 Sensor Low	When over low warning is enabled, and the controller detects the sensor value is below the preset lower limit, it shall issue a warning. It is detected after "safety on time" before "ETS solenoid hold" when the sensor is selected as temperature sensor and pressure sensor; It is always detected when the sensor is selected as fuel level sensor.

No	Type	Description
60	Power Factor Low	When this is enabled and the controller detects that the generator power factor has fallen below the pre-set value, it will initiate a warning alarm. It is always detected.
61	THD High	When this is enabled and the controller detects that the THD has exceeded the pre-set value, it will initiate a warning alarm. It is always detected.
62	Gen Volt Unbalance	When this is enabled and the controller detects that the voltage unbalanced value has exceeded the pre-set value, it will initiate a warning alarm. It is always detected.
63	Cycle Start Comm. Fail	Cycle start is enabled, when controller cannot receive the communication data of another controller, controller issues alarm signal. It is detected when controller is in auto mode.
64	SGE02-4G Comm. Fail	When SGE02 (4G wireless communication expansion card) is enabled, and GSM module is not detected, controller issues a warning signal; It is detected always.
65	AIN16-M02 Comm. Fail	When AIN16-M02 is enabled, and when controller cannot receive the communication data of AIN16-M02 module, controller issues a warning signal; It is detected always.
66	AIN16-M02 Sensor Open	When controller detects sensor is open, controller issues an alarm signal; It is detected always.
67	AIN16-M02 Sensor High	When over high warning is enabled, and the controller detects the sensor value is above the preset upper limit, it shall issue a warning. It is detected after "safety on time" before "ETS solenoid hold" when the sensor is selected as temperature sensor and pressure sensor; It is always detected when the sensor is selected as fuel level sensor.
68	AIN16-M02 Sensor Low	When over low warning is enabled, and the controller detects the sensor value is below the preset lower limit, it shall issue a warning. It is detected after "safety on time" before "ETS solenoid hold" when the sensor is selected as temperature sensor and pressure sensor; It is always detected when the sensor is selected as fuel level sensor.
69	AIN8 Comm. Fail	AIN8 enabled; when controller cannot receive AIN8 module communication data, it will issue alarm signal; It is detected always.
70	AIN8 Sensor Open	When controller detects sensor open, it issues alarm signal; It is detected always.
71	AIN8 Sensor High	Enabled; when the sensor value detected by the controller is over the pre-set upper limit, controller issues alarm signal; When sensor type selects temp sensor and pressure sensor, it is

No	Type	Description
		detected after "safety on time" before "ETS solenoid hold"; It is detected always when sensor type selects liquid level sensor.
72	AIN8 Sensor Low	Enabled; when the sensor value detected by the controller is below the pre-set lower limit, controller issues alarm signal; When sensor type selects temp sensor and pressure sensor, it is detected after "safety on time" before "ETS solenoid hold"; It is detected always when sensor type selects liquid level sensor.
73	BAC150CAN Comm. Fail	When BAC150CAN is enabled, and when controller cannot receive communication data of BAC150CAN module, controller issues a warning signal; It is always detected.

SmartGen

**6.2 BLOCK ALARMS**

When the controller detects block signals, it only issues warning and the genset does not shut down and not open. Users need to reset alarms manually.

**Table 8 Block Alarms**

No	Type	Description
1	Over Speed	When this is enabled, and the controller detects that the genset speed is above the pre-set limit, it will initiate a block alarm. It is always detected.
2	Under Speed	When this is enabled and the controller detects that the genset speed is below the pre-set limit, it will initiate a block alarm. It is detected after "warming up" and before "stop idle".
3	Loss of Speed Signal	When the controller detects the genset speed is 0, it shall issue a block alarm. It is detected after "safety on time" before "ETS solenoid hold".
4	Gen Over Frequency	When this is enabled, and the controller detects the genset frequency is above preset limit, it shall issue a block alarm. It is always detected.
5	Gen Under Frequency	When this is enabled, and the controller detects the frequency is below the preset limit, it shall issue a block alarm. It is detected after "warming up" and before "stop idle".
6	Gen Over Voltage	When this is enabled, and the controller detects the genset voltage is above preset limit, it shall issue a block alarm. It is always detected.
7	Gen Under Voltage	When this is enabled, and the controller detects the voltage is below the preset limit, it shall issue a block alarm. It is detected after "warming up" and before "stop idle".
8	Gen Over Current	When this is enabled, and the controller detects the genset current is above preset limit, it shall issue a block alarm. It is always detected.
9	Unbalanced Current	When this is enabled, and the controller detects the unbalanced current is above preset limit, it shall issue a block alarm. It is always detected.
10	Earth Fault	When this is enabled, and the controller detects the earth current is above the preset limit, it shall issue a block alarm. It is always detected.
11	Reverse Power	When this is enabled, and the controller detects the reverse power (negative) is above the preset limit, it shall issue a block alarm. It is always detected.
12	Over Power	When this is enabled, and the controller detects the genset power (positive) is above the preset limit, it shall issue a block alarm. It is always detected.
13	Loss Excitation Fault	When this is enabled, and the controller detects the genset reactive

No	Type	Description
		power (negative) is above the preset limit, it shall issue a block alarm. It is always detected.
14	ECU Alarm	When the controller receives the engine alarm signal from J1939, it shall issue a block alarm. It is always detected.
15	Temp. Sensor Open	When the controller detects the sensor circuit is open, it shall issue a block alarm. It is always detected.
16	Engine Temp High	When this is enabled, and the controller detects the temp. is above the preset limit, it shall issue a block alarm. It is detected after "safety on time" before "ETS solenoid hold".
17	Engine Temp Low	When this is enabled, and the controller detects the temp. is below the preset limit, it shall issue a block alarm. It is detected after "safety on time" before "ETS solenoid hold".
18	Oil Pressure Sensor Open	When the controller detects the sensor circuit is open, it shall issue a block alarm. It is always detected.
19	Oil Pressure Low	When this is enabled, and the controller detects the pressure is below the preset limit, it shall issue a block alarm. It is detected after "safety on time" before "ETS solenoid hold".
20	Oil Pressure Sensor Wrong	When voltage or current input is selected for the curve type of the controller, and the controller detects input signal is abnormal, it shall issue a block alarm, and meanwhile the curve is transferred to resistance type to prevent damaging the controller. It is always detected.
21	Fuel Level Sensor Open	When the controller detects the sensor circuit is open, it shall issue a block alarm. It is always detected.
22	Fuel Level Low	When this is enabled, and the controller detects the level is below the preset limit, it shall issue a block alarm. It is always detected.
23	Fuel Level Sensor Wrong	When voltage or current input is selected for the curve type of the controller, and the controller detects input signal is abnormal, it shall issue a block alarm, and meanwhile the curve is transferred to resistance type to prevent damaging the controller. It is detected always.
24	Flex. Sensor 1 Open	When the controller detects the sensor circuit is open, it shall issue a block alarm. It is always detected.
25	Flex. Sensor 1 High	When over high block alarm is enabled, and the controller detects the sensor value is above the preset upper limit, it shall issue a block alarm. It is detected after "safety on time" before "ETS solenoid hold" when the sensor is selected as temperature sensor and pressure sensor;

No	Type	Description
		It is always detected when the sensor is selected as fuel level sensor.
26	Flex. Sensor 1 Low	When over low block alarm is enabled, and the controller detects the sensor value is below the preset low limit, it shall issue a block alarm. It is detected after "safety on time" before "ETS solenoid hold" when the sensor is selected as temperature sensor and pressure sensor; It is always detected when the sensor is selected as fuel level sensor.
27	Flex. Sensor 1 Wrong	When voltage or current input is selected for the curve type of the controller, and the controller detects input signal is abnormal, it shall issue a block alarm, and meanwhile the curve is transferred to resistance type to prevent damaging the controller. It is always detected.
28	Flex. Sensor 2 Open	When the controller detects the sensor circuit is open, it shall issue a block alarm. It is always detected.
29	Flex. Sensor 2 High	When over high block alarm is enabled, and the controller detects the sensor value is above the preset upper limit, it shall issue a block alarm. It is detected after "safety on time" before "ETS solenoid hold" when the sensor is selected as temperature sensor and pressure sensor; It is always detected when the sensor is selected as fuel level sensor.
30	Flex. Sensor 2 Low	When over low block alarm is enabled, and the controller detects the sensor value is below the preset low limit, it shall issue a block alarm. It is detected after "safety on time" before "ETS solenoid hold" when the sensor is selected as temperature sensor and pressure sensor; It is always detected when the sensor is selected as fuel level sensor.
31	Flex. Sensor 2 Wrong	When voltage or current input is selected for the curve type of the controller, and the controller detects input signal is abnormal, it shall issue a block alarm, and meanwhile the curve is transferred to resistance type to prevent damaging the controller. It is always detected.
32	Flex. Sensor 3 Open	When the controller detects the sensor circuit is open, it shall issue a block alarm. It is always detected.
33	Flex. Sensor 3 High	When over high block alarm is enabled, and the controller detects the sensor value is above the preset upper limit, it shall issue a block alarm. It is detected after "safety on time" before "ETS solenoid hold" when the sensor is selected as temperature sensor and pressure sensor; It is always detected when the sensor is selected as fuel level sensor.
34	Flex. Sensor 3 Low	When over low block alarm is enabled, and the controller detects the sensor value is below the preset low limit, it shall issue a block alarm. It is detected after "safety on time" before "ETS solenoid hold" when the sensor is selected as temperature sensor and pressure sensor; It is always detected when the sensor is selected as fuel level sensor.
35	Failed to Stop	After "fail to stop delay" is over, if the genset does not stop completely,

No	Type	Description
		it will initiate a block alarm.
36	Charge Alternator Failure	When this is enabled, and the controller detects the charger voltage value is below the preset limit, it shall issue a block alarm. It is detected when the genset is normally running.
37	Battery Over Volt	When this is enabled, and the controller detects the battery voltage is above the preset limit, it shall issue a block signal. It is always detected.
38	Battery Under Volt	When this is enabled, and the controller detects the battery voltage is below the preset limit, it shall issue a block signal. It is always detected.
39	Maintenance Time 1 Due	Maintenance 1 enabled, when maintenance 1 countdown is equal to maintenance 1 countdown A or maintenance 1 countdown B, or maintenance 1 countdown is 0, controller will issue a block signal. It is detected when genset is running.
40	Maintenance Time 2 Due	Maintenance 2 enabled, when maintenance 2 countdown is equal to maintenance 2 countdown A or maintenance 2 countdown B, or maintenance 2 countdown is 0, controller will issue a block signal; It is detected when genset is running.
41	Maintenance Time 3 Due	Maintenance 3 enabled, when maintenance 3 countdown is equal to maintenance 3 countdown A or maintenance 3 countdown B, or maintenance 3 countdown is 0, controller will issue a block signal; It is detected when genset is running.
42	Digital Input Alarm	When the digital input port is set users-defined and if it is active, the controller will initiate a block signal for the input port. It is detected in the detection range set for the input port.
43	PLC Functions Alarm	When PLC function is set users-defined and if it is active, the controller will initiate a block signal. It is detected in the detection range set by the PLC function.
44	DIN16 Comm. Fail	When DIN16 communication is enabled and the controller cannot receive the communication data of DIN16, it will initiate a block signal. It is always detected.
45	DIN16 Input Alarm	When DIN16 input is set users-defined and if it is active, the controller will initiate a block signal. It is detected in the detection range set in the input.
46	DOUT16 Comm. Fail	When DOUT16 communication is enabled and the controller cannot receive the communication data of DOUT16, it will initiate a block signal. It is always detected.
47	AIN24 Comm. Fail	When AIN24 communication is enabled and the controller cannot receive the communication data, it will initiate a block signal. It is always detected.
48	AIN24 Cylinder Temp. High	When this is enabled and the controller detects cylinder temperature has exceeded the pre-set value, it will initiate a block alarm.

No	Type	Description
		It is detected after "safety on time" before "ETS solenoid hold".
49	AIN24 Exhaust Temp. High	When this is enabled and the controller detects exhaust temperature has exceeded the pre-set value, it will initiate a block alarm. It is detected after "safety on time" before "ETS solenoid hold".
50	AIN24 Cylinder Temp. Difference High	When this is enabled and the controller detects cylinder temp. difference has exceeded the pre-set value, it will initiate a block alarm. It is detected after "safety on time" before "ETS solenoid hold".
51	AIN24 Sensor Open	When the controller detects the sensor circuit is open, it shall issue a block alarm. It is always detected.
52	AIN24 Sensor High	When over high alarm is enabled, and the controller detects the sensor value is above the preset upper limit, it shall issue a block alarm. It is detected after "safety on time" before "ETS solenoid hold" when the sensor is selected as temperature sensor and pressure sensor; It is always detected when the sensor is selected as fuel level sensor.
53	AIN24 Sensor Low	When over low alarm is enabled, and the controller detects the sensor value is below the preset lower limit, it shall issue a block alarm. It is detected after "safety on time" before "ETS solenoid hold" when the sensor is selected as temperature sensor and pressure sensor; It is always detected when the sensor is selected as fuel level sensor.
54	Power Factor Low	When this is enabled and the controller detects that the generator power factor has fallen below the pre-set limit, it will initiate a block alarm. It is always detected.
55	THD High	When this is enabled and the controller detects that the THD has exceeded the pre-set limit, it will initiate a block alarm. It is always detected.
56	Gen Volt Imbalance	When this is enabled and the controller detects that the voltage unbalanced value has exceeded the pre-set limit, it will initiate a block alarm. It is always detected.
57	AIN16-M02 Comm. Fail	When AIN16-M02 is enabled, and when controller cannot receive the communication data of AIN16-M02 module, controller issues a block signal; It is always detected.
58	AIN16-M02 Sensor Open	When controller detects sensor is open, controller issues an alarm signal; It is always detected.
59	AIN16-M02 Sensor High	When over high alarm is enabled, and the controller detects the sensor value is above the preset upper limit, it shall issue an alarm. It is detected after "safety on time" before "ETS solenoid hold" when the sensor is selected as temperature sensor and pressure sensor; It is always detected when the sensor is selected as fuel level sensor.

No	Type	Description
60	AIN16-M02 Sensor Low	When over low alarm is enabled, and the controller detects the sensor value is below the preset lower limit, it shall issue an alarm. It is detected after "safety on time" before "ETS solenoid hold" when the sensor is selected as temperature sensor and pressure sensor; It is always detected when the sensor is selected as fuel level sensor.
61	AIN8 Comm. Fail	AIN8 enabled; when controller cannot receive AIN8 module communication data, it will issue alarm signal; It is always detected.
62	AIN8 Sensor Open	When controller detects sensor open, it issues alarm signal; It is always detected.
63	AIN8 Sensor High	Enabled; when the sensor value detected by the controller is over the pre-set upper limit, controller issues alarm signal; When sensor type selects temp sensor and pressure sensor, it is detected after safety on run before ETS stop; It is detected always when sensor type selects liquid level sensor.
64	AIN8 Sensor Low	Enabled; when the sensor value detected by the controller is below the pre-set lower limit, controller issues alarm signal; When sensor type selects temp sensor and pressure sensor, it is detected after safety on run before ETS stop; It is detected always when sensor type selects liquid level sensor.
65	BAC150CAN Comm. Fail	When BAC150CAN is enabled, and when controller cannot receive communication data of BAC150CAN module, controller issues an alarm signal; It is always detected.

**6.3 TRIP ALARMS**

When controller detects safety trip signals, it will open breaker immediately but not stop the genset. Users need to reset alarms manually.

**Table 9 Trip Alarms**

No	Type	Description
1	Over Speed	When this is enabled, and the controller detects that the genset speed is above the pre-set limit, it will initiate an alarm signal. It is always detected.
2	Under Speed	When this is enabled and the controller detects that the genset speed is below the pre-set limit, it will initiate an alarm signal. It is detected after "warming up" and before "stop idle".
3	Loss of Speed Signal	When the controller detects the genset speed is 0, it shall issue an alarm signal. It is detected after "safety on time" before "ETS solenoid hold".
4	Gen Over Frequency	When this is enabled, and the controller detects the genset frequency is above preset limit, it shall issue an alarm signal. It is always detected.
5	Gen Under Frequency	When this is enabled, and the controller detects the frequency is below the preset limit, it shall issue an alarm signal. It is detected after "warming up" and before "stop idle".
6	Gen Over Voltage	When this is enabled, and the controller detects the genset voltage is above preset limit, it shall issue an alarm signal. It is always detected.
7	Gen Under Voltage	When this is enabled, and the controller detects the voltage is below the preset limit, it shall issue an alarm signal. It is detected after "warming up" and before "stop idle".
8	Gen Over Current	When this is enabled, and the controller detects the genset current is above preset limit, it shall issue an alarm signal. It is always detected.
9	Unbalanced Current	When this is enabled, and the controller detects the unbalanced current is above preset limit, it shall issue an alarm signal. It is always detected.
10	Earth Fault	When this is enabled, and the controller detects the earth current is above the preset limit, it shall issue an alarm signal. It is always detected.
11	Reverse Power	When this is enabled, and the controller detects the reverse power (negative) is above the preset limit, it shall issue an alarm signal. It is always detected.
12	Over Power	When this is enabled, and the controller detects the genset power (positive) is above the preset limit, it shall issue an alarm signal. It is always detected.
13	Loss Excitation Fault	When this is enabled, and the controller detects the genset reactive

No	Type	Description
		power (negative) is above the preset limit, it shall issue an alarm signal. It is always detected.
14	ECU Alarm	When the controller receives the engine alarm signal from J1939, it shall issue an alarm signal. It is always detected.
15	Temp. Sensor Open	When the controller detects the sensor circuit is open, it shall issue an alarm signal. It is always detected.
16	Engine Temp High	When this is enabled, and the controller detects the temp. is above the preset limit, it shall issue an alarm signal. It is detected after "safety on time" before "ETS solenoid hold".
17	Engine Temp Low	When this is enabled, and the controller detects the temp. is below the preset limit, it shall issue an alarm signal. It is detected after "safety on time" before "ETS solenoid hold".
18	Oil Pressure Sensor Open	When the controller detects the sensor circuit is open, it shall issue an alarm signal. It is always detected.
19	Oil Pressure Low	When this is enabled, and the controller detects the pressure is below the preset limit, it shall issue an alarm signal. It is detected after "safety on time" before "ETS solenoid hold".
20	Oil Pressure Sensor Wrong	When voltage or current input is selected for the curve type of the controller, and the controller detects input signal is abnormal, it shall issue an alarm signal, and meanwhile the curve is transferred to resistance type to prevent damaging the controller. It is detected always.
21	Fuel Level Sensor Open	When the controller detects the sensor circuit is open, it shall issue an alarm signal. It is always detected.
22	Fuel Level Low	When this is enabled, and the controller detects the level is below the preset limit, it shall issue an alarm signal. It is always detected.
23	Fuel Level Sensor Wrong	When voltage or current input is selected for the curve type of the controller, and the controller detects input signal is abnormal, it shall issue an alarm signal, and meanwhile the curve is transferred to resistance type to prevent damaging the controller. It is always detected.
24	Flex. Sensor 1 Open	When the controller detects the sensor circuit is open, it shall issue an alarm signal. It is always detected.
25	Flex. Sensor 1 High	When over high alarm is enabled, and the controller detects the sensor value is above the preset upper limit, it shall issue an alarm signal. It is detected after "safety on time" before "ETS solenoid hold" when the sensor is selected as temperature sensor and pressure sensor;

No	Type	Description
		It is always detected when the sensor is selected as fuel level sensor.
26	Flex. Sensor 1 Low	When over low alarm is enabled, and the controller detects the sensor value is below the preset low limit, it shall issue an alarm signal. It is detected after "safety on time" before "ETS solenoid hold" when the sensor is selected as temperature sensor and pressure sensor; It is always detected when the sensor is selected as fuel level sensor.
27	Flex. Sensor 1 Wrong	When voltage or current input is selected for the curve type of the controller, and the controller detects input signal is abnormal, it shall issue an alarm signal, and meanwhile the curve is transferred to resistance type to prevent damaging the controller. It is always detected.
28	Flex. Sensor 2 Open	When the controller detects the sensor circuit is open, it shall issue an alarm signal. It is always detected.
29	Flex. Sensor 2 High	When over high alarm is enabled, and the controller detects the sensor value is above the preset upper limit, it shall issue an alarm signal. It is detected after "safety on time" before "ETS solenoid hold" when the sensor is selected as temperature sensor and pressure sensor; It is always detected when the sensor is selected as fuel level sensor.
30	Flex. Sensor 2 Low	When over low alarm is enabled, and the controller detects the sensor value is below the preset low limit, it shall issue an alarm signal. It is detected after "safety on time" before "ETS solenoid hold" when the sensor is selected as temperature sensor and pressure sensor; It is always detected when the sensor is selected as fuel level sensor.
31	Flex. Sensor 2 Wrong	When voltage or current input is selected for the curve type of the controller, and the controller detects input signal is abnormal, it shall issue an alarm signal, and meanwhile the curve is transferred to resistance type to prevent damaging the controller. It is always detected.
32	Flex. Sensor 3 Open	When the controller detects the sensor circuit is open, it shall issue an alarm signal. It is always detected.
33	Flex. Sensor 3 High	When over high alarm is enabled, and the controller detects the sensor value is above the preset upper limit, it shall issue an alarm signal. It is detected after "safety on time" before "ETS solenoid hold" when the sensor is selected as temperature sensor and pressure sensor; It is always detected when the sensor is selected as fuel level sensor.
34	Flex. Sensor 3 Low	When over low alarm is enabled, and the controller detects the sensor value is below the preset low limit, it shall issue an alarm signal. It is detected after "safety on time" before "ETS solenoid hold" when the sensor is selected as temperature sensor and pressure sensor; It is always detected when the sensor is selected as fuel level sensor.
35	Charge Alternator	When this is enabled, and the controller detects the charger voltage

No	Type	Description
	Failure	value is below the preset limit, it shall issue an alarm signal. It is detected when the genset is normally running.
36	Battery Over Volt	When this is enabled, and the controller detects the battery voltage is above the preset limit, it shall issue an alarm signal. It is always detected.
37	Battery Under Volt	When this is enabled, and the controller detects the battery voltage is below the preset limit, it shall issue an alarm signal. It is always detected.
38	Fail to Sync.	If the controller doesn't detect sync. signal within the pre-set time, it will initiate an alarm signal. It is detected when breaker closes.
39	Gen C/O Alarm	When sync. transfer is enabled and controller detects gen switch close/open failure, controller issues an alarm signal; It is always detected.
40	Mains C/O Alarm	When sync. transfer is enabled and controller detects mains switch close/open failure, controller issues an alarm signal; It is always detected.
41	Maintenance Time 1 Due	When this is enabled, and when maintenance 1 countdown is equal to maintenance 1 countdown A or maintenance 1 countdown B, or maintenance 1 countdown is 0, controller will initiate an alarm signal. It is detected when the genset is running.
42	Maintenance Time 2 Due	When this is enabled, and when maintenance 2 countdown is equal to maintenance 2 countdown A or maintenance 2 countdown B, or maintenance 2 countdown is 0, controller will initiate an alarm signal. It is detected when the genset is running.
43	Maintenance Time 3 Due	When this is enabled, and when maintenance 3 countdown is equal to maintenance 3 countdown A or maintenance 3 countdown B, or maintenance 3 countdown is 0, controller will initiate an alarm signal. It is detected when the genset is running.
44	Digital Input Alarm	When the digital input port is set users-defined and if it is active, the controller will initiate an alarm signal for the input port. It is detected in the detection range set for the input port.
45	PLC Functions Alarm	When PLC function is set users-defined and if it is active, the controller will initiate an alarm signal. It is detected in the detection range set by the PLC function.
46	DIN16 Comm. Fail	When DIN16 communication is enabled and the controller cannot receive the communication data of DIN16, it will initiate an alarm signal. It is always detected.
47	DIN16 Input Alarm	When DIN16 input is set users-defined and if it is active, the controller will initiate an alarm signal. It is detected in the detection range set in the input.
48	DOUT16 Comm. Fail	When DOUT16 communication is enabled and the controller cannot receive the communication data of DOUT16, it will initiate an alarm

No	Type	Description
		signal. It is always detected.
49	AIN24 Comm. Fail	When AIN24 communication is enabled and the controller cannot receive the communication data of AIN24 module, it will initiate an alarm signal. It is always detected.
50	AIN24 Cylinder Temp. High	When this is enabled and the controller detects cylinder temperature has exceeded the pre-set value, it will initiate an alarm signal. It is detected after "safety on time" before "ETS solenoid hold".
51	AIN24 Exhaust Temp. High	When this is enabled and the controller detects exhaust temperature has exceeded the pre-set value, it will initiate an alarm signal. It is detected after "safety on time" before "ETS solenoid hold".
52	AIN24 Cylinder Temp. Difference High	When this is enabled and the controller detects cylinder temp. difference has exceeded the pre-set value, it will initiate an alarm signal. It is detected after "safety on time" before "ETS solenoid hold".
53	AIN24 Sensor Open	When the controller detects the sensor circuit is open, it shall issue an alarm signal. It is always detected.
54	AIN24 Sensor High	When over high alarm is enabled, and the controller detects the sensor value is above the preset upper limit, it shall issue an alarm signal. It is detected after "safety on time" before "ETS solenoid hold" when the sensor is selected as temperature sensor and pressure sensor; It is always detected when the sensor is selected as fuel level sensor.
55	AIN24 Sensor Low	When over low alarm is enabled, and the controller detects the sensor value is below the preset lower limit, it shall issue an alarm signal. It is detected after "safety on time" before "ETS solenoid hold" when the sensor is selected as temperature sensor and pressure sensor; It is always detected when the sensor is selected as fuel level sensor.
56	Power Factor Low	When this is enabled and the controller detects that the generator power factor has fallen below the pre-set limit, it will initiate an alarm signal. It is always detected.
57	THD High	When this is enabled and the controller detects that the THD has exceeded the pre-set limit, it will initiate an alarm signal. It is always detected.
58	Gen Volt Unbalance	When this is enabled and the controller detects that the voltage unbalanced value has exceeded the pre-set limit, it will initiate an alarm signal. It is always detected.
59	AIN16-M02 Comm. Fail	When AIN16-M02 is enabled, and when controller cannot receive the communication data of AIN16-M02 module, controller issues an alarm signal; It is always detected.

No	Type	Description
60	AIN16-M02 Sensor Open	When controller detects sensor is open, controller issues an alarm signal; It is always detected.
61	AIN16-M02 Sensor High	When over high alarm is enabled, and the controller detects the sensor value is above the preset upper limit, it shall issue an alarm. It is detected after "safety on time" before "ETS solenoid hold" when the sensor is selected as temperature sensor and pressure sensor; It is always detected when the sensor is selected as fuel level sensor.
62	AIN16-M02 Sensor Low	When over low alarm is enabled, and the controller detects the sensor value is below the preset lower limit, it shall issue an alarm. It is detected after "safety on time" before "ETS solenoid hold" when the sensor is selected as temperature sensor and pressure sensor; It is always detected when the sensor is selected as fuel level sensor.
63	AIN8 Comm. Fail	AIN8 enabled; when controller cannot receive AIN8 module communication data, it will issue alarm signal; It is always detected.
64	AIN8 Sensor Open	When controller detects sensor open, it issues alarm signal; It is always detected.
65	AIN8 Sensor High	Enabled; when the sensor value detected by the controller is over the pre-set upper limit, controller issues alarm signal; When sensor type selects temp sensor and pressure sensor, it is detected after "safety on time" before "ETS solenoid hold"; It is detected always when sensor type selects liquid level sensor.
66	AIN8 Sensor Low	Enabled; when the sensor value detected by the controller is below the pre-set lower limit, controller issues alarm signal; When sensor type selects temp sensor and pressure sensor, it is detected after "safety on time" before "ETS solenoid hold"; It is detected always when sensor type selects liquid level sensor.
67	BAC150CAN Comm. Fail	When BAC150CAN is enabled, and when controller cannot receive communication data of BAC150CAN module, controller issues an alarm signal; It is always detected.

**6.4 TRIP AND STOP ALARMS**

When controller detects trip and stop signals, it will open breaker directly and genset stops after cooling. Users need to reset alarms manually.

**Table 10 Trip and Stop Alarms**

No	Type	Description
1	Over Speed	When this is enabled, and the controller detects that the genset speed is above the pre-set limit, it will initiate an alarm signal. It is always detected.
2	Under Speed	When this is enabled and the controller detects that the genset speed is below the pre-set limit, it will initiate an alarm signal. It is detected after "warming up" and before "stop idle".
3	Loss of Speed Signal	When the controller detects the genset speed is 0, it shall issue an alarm signal. It is detected after "safety on time" before "ETS solenoid hold".
4	Gen Over Frequency	When this is enabled, and the controller detects the genset frequency is above preset limit, it shall issue an alarm signal. It is always detected.
5	Gen Under Frequency	When this is enabled, and the controller detects the frequency is below the preset limit, it shall issue an alarm signal. It is detected after "warming up" and before "stop idle".
6	Gen Over Voltage	When this is enabled, and the controller detects the genset voltage is above preset limit, it shall issue an alarm signal. It is always detected.
7	Gen Under Voltage	When this is enabled, and the controller detects the voltage is below the preset limit, it shall issue an alarm signal. It is detected after "warming up" and before "stop idle".
8	Gen Over Current	When this is enabled, and the controller detects the genset current is above preset limit, it shall issue an alarm signal. It is always detected.
9	Unbalanced Current	When this is enabled, and the controller detects the unbalanced current is above preset limit, it shall issue an alarm signal. It is always detected.
10	Earth Fault	When this is enabled, and the controller detects the earth current is above the preset limit, it shall issue an alarm signal. It is always detected.
11	Reverse Power	When this is enabled, and the controller detects the reverse power (negative) is above the preset limit, it shall issue an alarm signal. It is always detected.
12	Over Power	When this is enabled, and the controller detects the genset power (positive) is above the preset limit, it shall issue an alarm signal. It is always detected.
13	Loss Excitation Fault	When this is enabled, and the controller detects the genset reactive

No	Type	Description
		power (negative) is above the preset limit, it shall issue an alarm signal. It is always detected.
14	ECU Alarm	When the controller receives the engine alarm signal from J1939, it shall issue an alarm signal. It is always detected.
15	Temp. Sensor Open	When the controller detects the sensor circuit is open, it shall issue an alarm signal. It is always detected.
16	Engine Temp High	When this is enabled, and the controller detects the temp. is above the preset limit, it shall issue an alarm signal. It is detected after "safety on time" before "ETS solenoid hold".
17	Engine Temp Low	When this is enabled, and the controller detects the temp. is below the preset limit, it shall issue an alarm signal. It is detected after "safety on time" before "ETS solenoid hold".
18	Oil Pressure Sensor Open	When the controller detects the sensor circuit is open, it shall issue an alarm signal. It is always detected.
19	Oil Pressure Low	When this is enabled, and the controller detects the pressure is below the preset limit, it shall issue an alarm signal. It is detected after "safety on time" before "ETS solenoid hold".
20	Oil Pressure Sensor Wrong	When voltage or current input is selected for the curve type of the controller, and the controller detects input signal is abnormal, it shall issue an alarm signal, and meanwhile the curve is transferred to resistance type to prevent damaging the controller. It is always detected.
21	Fuel Level Sensor Open	When the controller detects the sensor circuit is open, it shall issue an alarm signal. It is always detected.
22	Fuel Level Low	When this is enabled, and the controller detects the level is below the preset limit, it shall issue an alarm signal. It is always detected.
23	Fuel Level Sensor Wrong	When voltage or current input is selected for the curve type of the controller, and the controller detects input signal is abnormal, it shall issue an alarm signal, and meanwhile the curve is transferred to resistance type to prevent damaging the controller. It is always detected.
24	Flex. Sensor 1 Open	When the controller detects the sensor circuit is open, it shall issue an alarm signal. It is always detected.
25	Flex. Sensor 1 High	When over high alarm is enabled, and the controller detects the sensor value is above the preset upper limit, it shall issue an alarm signal. It is detected after "safety on time" before "ETS solenoid hold" when the sensor is selected as temperature sensor and pressure sensor;

No	Type	Description
		It is always detected when the sensor is selected as fuel level sensor.
26	Flex. Sensor 1 Low	When over low alarm is enabled, and the controller detects the sensor value is below the preset low limit, it shall issue an alarm signal. It is detected after "safety on time" before "ETS solenoid hold" when the sensor is selected as temperature sensor and pressure sensor; It is always detected when the sensor is selected as fuel level sensor.
27	Flex. Sensor 1 Wrong	When voltage or current input is selected for the curve type of the controller, and the controller detects input signal is abnormal, it shall issue an alarm signal, and meanwhile the curve is transferred to resistance type to prevent damaging the controller. It is always detected.
28	Flex. Sensor 2 Open	When the controller detects the sensor circuit is open, it shall issue an alarm signal. It is always detected.
29	Flex. Sensor 2 High	When over high alarm is enabled, and the controller detects the sensor value is above the preset upper limit, it shall issue an alarm signal. It is detected after "safety on time" before "ETS solenoid hold" when the sensor is selected as temperature sensor and pressure sensor; It is always detected when the sensor is selected as fuel level sensor.
30	Flex. Sensor 2 Low	When over low alarm is enabled, and the controller detects the sensor value is below the preset low limit, it shall issue an alarm signal. It is detected after "safety on time" before "ETS solenoid hold" when the sensor is selected as temperature sensor and pressure sensor; It is always detected when the sensor is selected as fuel level sensor.
31	Flex. Sensor 2 Wrong	When voltage or current input is selected for the curve type of the controller, and the controller detects input signal is abnormal, it shall issue an alarm signal, and meanwhile the curve is transferred to resistance type to prevent damaging the controller. It is always detected.
32	Flex. Sensor 3 Open	When the controller detects the sensor circuit is open, it shall issue an alarm signal. It is always detected.
33	Flex. Sensor 3 High	When over high alarm is enabled, and the controller detects the sensor value is above the preset upper limit, it shall issue an alarm signal. It is detected after "safety on time" before "ETS solenoid hold" when the sensor is selected as temperature sensor and pressure sensor; It is always detected when the sensor is selected as fuel level sensor.
34	Flex. Sensor 3 Low	When over low alarm is enabled, and the controller detects the sensor value is below the preset low limit, it shall issue an alarm signal. It is detected after "safety on time" before "ETS solenoid hold" when the sensor is selected as temperature sensor and pressure sensor; It is always detected when the sensor is selected as fuel level sensor.
35	Charge Alternator	When this is enabled, and the controller detects the charger voltage

No	Type	Description
	Failure	value is below the preset limit, it shall issue an alarm signal. It is detected when the genset is normally running.
36	Battery Over Volt	When this is enabled, and the controller detects the battery voltage is above the preset limit, it shall issue an alarm signal. It is always detected.
37	Battery Under Volt	When this is enabled, and the controller detects the battery voltage is below the preset limit, it shall issue an alarm signal. It is always detected.
38	Maintenance Time 1 Due	When this is enabled, and when maintenance 1 countdown is equal to maintenance 1 countdown A or maintenance 1 countdown B, or maintenance 1 countdown is 0, controller will initiate an alarm signal. It is detected when the genset is running.
39	Maintenance Time 2 Due	When this is enabled, and when maintenance 2 countdown is equal to maintenance 2 countdown A or maintenance 2 countdown B, or maintenance 2 countdown is 0, controller will initiate an alarm signal. It is detected when the genset is running.
40	Maintenance Time 3 Due	When this is enabled, and when maintenance 3 countdown is equal to maintenance 3 countdown A or maintenance 3 countdown B, or maintenance 3 countdown is 0, controller will initiate an alarm signal. It is detected when the genset is running.
41	Digital Input Alarm	When the digital input port is set users-defined and if it is active, the controller will initiate an alarm signal for the input port. It is detected in the detection range set for the input port.
42	PLC Functions Alarm	When PLC function is set users-defined and if it is active, the controller will initiate an alarm signal. It is detected in the detection range set by the PLC function.
43	DIN16 Comm. Fail	When DIN16 communication is enabled and the controller cannot receive the communication data of DIN16, it will initiate an alarm signal. It is always detected.
44	DIN16 Input Alarm	When DIN16 input is set users-defined and if it is active, the controller will initiate an alarm signal. It is detected in the detection range set in the input.
45	DOUT16 Comm. Fail	When DOUT16 communication is enabled and the controller cannot receive the communication data, it will initiate an alarm signal. It is always detected.
46	AIN24 Comm. Fail	When AIN24 communication is enabled and the controller cannot receive the communication data of AIN24, it will initiate an alarm signal. It is always detected.
47	AIN24 Cylinder Temp. High	When this is enabled and the controller detects cylinder temperature has exceeded the pre-set value, it will initiate an alarm signal. It is detected after "safety on time" before "ETS solenoid hold".
48	AIN24 Exhaust Temp. High	When this is enabled and the controller detects exhaust temperature has exceeded the pre-set value, it will initiate an alarm signal.

No	Type	Description
		It is detected after "safety on time" before "ETS solenoid hold".
49	AIN24 Cylinder Temp. Difference High	When this is enabled and the controller detects cylinder temp. difference has exceeded the pre-set value, it will initiate an alarm signal. It is detected after "safety on time" before "ETS solenoid hold".
50	AIN24 Sensor Open	When the controller detects the sensor circuit is open, it shall issue an alarm signal. It is always detected.
51	AIN24 Sensor High	When over high alarm is enabled, and the controller detects the sensor value is above the preset upper limit, it shall issue an alarm signal. It is detected after "safety on time" before "ETS solenoid hold" when the sensor is selected as temperature sensor and pressure sensor; It is always detected when the sensor is selected as fuel level sensor.
52	AIN24 Sensor Low	When over low alarm is enabled, and the controller detects the sensor value is below the preset lower limit, it shall issue an alarm signal. It is detected after "safety on time" before "ETS solenoid hold" when the sensor is selected as temperature sensor and pressure sensor; It is always detected when the sensor is selected as fuel level sensor.
53	Power Factor Low	When this is enabled and the controller detects that the gen power factor has fallen below the pre-set limit, it will initiate an alarm signal. It is always detected.
54	THD High	When this is enabled and the controller detects that the THD has exceeded the pre-set limit, it will initiate an alarm signal. It is always detected.
55	Gen Volt Unbalance	When this is enabled and the controller detects that the voltage unbalanced value has exceeded the pre-set limit, it will initiate an alarm signal. It is always detected.
56	AIN16-M02 Comm. Fail	When AIN16-M02 is enabled, and when controller cannot receive the communication data of AIN16-M02 module, controller issues an alarm signal; It is always detected.
57	AIN16-M02 Sensor Open	When controller detects sensor is open, controller issues an alarm signal; It is always detected.
58	AIN16-M02 Sensor High	When over high alarm is enabled, and the controller detects the sensor value is above the preset upper limit, it shall issue an alarm. It is detected after "safety on time" before "ETS solenoid hold" when the sensor is selected as temperature sensor and pressure sensor; It is always detected when the sensor is selected as fuel level sensor.
59	AIN16-M02 Sensor Low	When over low alarm is enabled, and the controller detects the sensor value is below the preset lower limit, it shall issue an alarm. It is detected after "safety on time" before "ETS solenoid hold" when the sensor is selected as temperature sensor and pressure sensor;

No	Type	Description
		It is always detected when the sensor is selected as fuel level sensor.
60	AIN8 Comm. Fail	AIN8 enabled; when controller cannot receive AIN8 module communication data, it will issue alarm signal; It is always detected.
61	AIN8 Sensor Open	When controller detects sensor open, it issues alarm signal; It is always detected.
62	AIN8 Sensor High	Enabled; when the sensor value detected by the controller is over the pre-set upper limit, controller issues alarm signal; When sensor type selects temp sensor and pressure sensor, it is detected after "safety on time" before "ETS solenoid hold"; It is detected always when sensor type selects liquid level sensor.
63	AIN8 Sensor Low	Enabled; when the sensor value detected by the controller is below the pre-set lower limit, controller issues alarm signal; When sensor type selects temp sensor and pressure sensor, it is detected after "safety on time" before "ETS solenoid hold"; It is detected always when sensor type selects liquid level sensor.
64	BAC150CAN Comm. Fail	When BAC150CAN is enabled, and when controller cannot receive communication data of BAC150CAN module, controller issues an alarm signal; It is always detected.

**6.5 SHUTDOWN ALARMS**

When controller detects shutdown alarms, it will open breaker directly and shut down the generator. Users need to reset alarms manually.

**Table 11 Shutdown Alarms**

No	Type	Description
1	Emergency Stop	When the controller detects emergency stop signals, it will initiate a shutdown alarm signal. It is always detected.
2	Over Speed	When this is enabled, and the controller detects that the genset speed is above the pre-set limit, it will initiate an alarm signal. It is always detected.
3	Under Speed	When this is enabled and the controller detects that the genset speed is below the pre-set limit, it will initiate an alarm signal. It is detected after "warming up" and before "stop idle".
4	Loss of Speed Signal	When the controller detects the genset speed is 0, it shall issue an alarm signal. It is detected after "safety on time" before "ETS solenoid hold".
5	Gen Over Frequency	When this is enabled, and the controller detects the genset frequency is above preset limit, it shall issue an alarm signal. It is always detected.
6	Gen Under Frequency	When this is enabled, and the controller detects the frequency is below the preset limit, it shall issue an alarm signal. It is detected after "warming up" and before "stop idle".
7	Gen Over Voltage	When this is enabled, and the controller detects the genset voltage is above preset limit, it shall issue an alarm signal. It is always detected.
8	Gen Under Voltage	When this is enabled, and the controller detects the voltage is below the preset limit, it shall issue an alarm signal. It is detected after "warming up" and before "stop idle".
9	Gen Over Current	When this is enabled, and the controller detects the genset current is above preset limit, it shall issue an alarm signal. It is always detected.
10	Unbalanced Current	When this is enabled, and the controller detects the unbalanced current is above preset limit, it shall issue an alarm signal. It is always detected.
11	Earth Fault	When this is enabled, and the controller detects the earth current is above the preset limit, it shall issue an alarm signal. It is always detected.
12	Reverse Power	When this is enabled, and the controller detects the reverse power (negative) is above the preset limit, it shall issue an alarm signal. It is always detected.
13	Over Power	When this is enabled, and the controller detects the genset power

No	Type	Description
		(positive) is above the preset limit, it shall issue an alarm signal. It is always detected.
14	Loss Excitation Fault	When this is enabled, and the controller detects the genset reactive power (negative) is above the preset limit, it shall issue an alarm signal. It is always detected.
15	ECU Alarm	When the controller receives the engine alarm signal from J1939, it shall issue an alarm signal. It is always detected.
16	Temp. Sensor Open	When the controller detects the sensor circuit is open, it shall issue an alarm signal. It is always detected.
17	Engine Temp High	When this is enabled, and the controller detects the temp. is above the preset limit, it shall issue an alarm signal. It is detected after "safety on time" before "ETS solenoid hold".
18	Engine Temp Low	When this is enabled, and the controller detects the temp. is below the preset limit, it shall issue an alarm signal. It is detected after "safety on time" before "ETS solenoid hold".
19	Oil Pressure Sensor Open	When the controller detects the sensor circuit is open, it shall issue an alarm signal. It is always detected.
20	Oil Pressure Low	When this is enabled, and the controller detects the pressure is below the preset limit, it shall issue an alarm signal. It is detected after "safety on time" before "ETS solenoid hold".
21	Oil Pressure Sensor Wrong	When voltage or current input is selected for the curve type of the controller, and the controller detects input signal is abnormal, it shall issue an alarm signal, and meanwhile the curve is transferred to resistance type to prevent damaging the controller. It is always detected.
22	Fuel Level Sensor Open	When the controller detects the sensor circuit is open, it shall issue an alarm signal. It is always detected.
23	Fuel Level Low	When this is enabled, and the controller detects the level is below the preset limit, it shall issue an alarm signal. It is always detected.
24	Fuel Level Sensor Wrong	When voltage or current input is selected for the curve type of the controller, and the controller detects input signal is abnormal, it shall issue an alarm signal, and meanwhile the curve is transferred to resistance type to prevent damaging the controller. It is always detected.
25	Flex. Sensor 1 Open	When the controller detects the sensor circuit is open, it shall issue an alarm signal. It is always detected.
26	Flex. Sensor 1 High	When over high alarm is enabled, and the controller detects the sensor

No	Type	Description
		value is above the preset upper limit, it shall issue an alarm signal. It is detected after "safety on time" before "ETS solenoid hold" when the sensor is selected as temperature sensor and pressure sensor; It is always detected when the sensor is selected as fuel level sensor.
27	Flex. Sensor 1 Low	When over low alarm is enabled, and the controller detects the sensor value is below the preset low limit, it shall issue an alarm signal. It is detected after "safety on time" before "ETS solenoid hold" when the sensor is selected as temperature sensor and pressure sensor; It is always detected when the sensor is selected as fuel level sensor.
28	Flex. Sensor 1 Wrong	When voltage or current input is selected for the curve type of the controller, and the controller detects input signal is abnormal, it shall issue an alarm signal, and meanwhile the curve is transferred to resistance type to prevent damaging the controller. It is always detected.
29	Flex. Sensor 2 Open	When the controller detects the sensor circuit is open, it shall issue an alarm signal. It is always detected.
30	Flex. Sensor 2 High	When over high alarm is enabled, and the controller detects the sensor value is above the preset upper limit, it shall issue an alarm signal. It is detected after "safety on time" before "ETS solenoid hold" when the sensor is selected as temperature sensor and pressure sensor; It is always detected when the sensor is selected as fuel level sensor.
31	Flex. Sensor 2 Low	When over low alarm is enabled, and the controller detects the sensor value is below the preset low limit, it shall issue an alarm signal. It is detected after "safety on time" before "ETS solenoid hold" when the sensor is selected as temperature sensor and pressure sensor; It is always detected when the sensor is selected as fuel level sensor.
32	Flex. Sensor 2 Wrong	When voltage or current input is selected for the curve type of the controller, and the controller detects input signal is abnormal, it shall issue an alarm signal, and meanwhile the curve is transferred to resistance type to prevent damaging the controller. It is always detected.
33	Flex. Sensor 3 Open	When the controller detects the sensor circuit is open, it shall issue an alarm signal. It is always detected.
34	Flex. Sensor 3 High	When over high alarm is enabled, and the controller detects the sensor value is above the preset upper limit, it shall issue an alarm signal. It is detected after "safety on time" before "ETS solenoid hold" when the sensor is selected as temperature sensor and pressure sensor; It is always detected when the sensor is selected as fuel level sensor.
35	Flex. Sensor 3 Low	When over low alarm is enabled, and the controller detects the sensor value is below the preset low limit, it shall issue an alarm signal. It is detected after "safety on time" before "ETS solenoid hold" when the

No	Type	Description
		sensor is selected as temperature sensor and pressure sensor; It is always detected when the sensor is selected as fuel level sensor.
36	Charge Alternator Failure	When this is enabled, and the controller detects the charger voltage value is below the preset limit, it shall issue an alarm signal. It is detected when the genset is normally running.
37	Battery Over Volt	When this is enabled, and the controller detects the battery voltage is above the preset limit, it shall issue an alarm signal. It is always detected.
38	Battery Under Volt	When this is enabled, and the controller detects the battery voltage is below the preset limit, it shall issue an alarm signal. It is always detected.
39	Maintenance Time 1 Due	When this is enabled, and when maintenance 1 countdown is equal to maintenance 1 countdown A or maintenance 1 countdown B, or maintenance 1 countdown is 0, controller will initiate an alarm signal. It is detected when the genset is running.
40	Maintenance Time 2 Due	When this is enabled, and when maintenance 2 countdown is equal to maintenance 2 countdown A or maintenance 2 countdown B, or maintenance 2 countdown is 0, controller will initiate an alarm signal. It is detected when the genset is running.
41	Maintenance Time 3 Due	When this is enabled, and when maintenance 3 countdown is equal to maintenance 3 countdown A or maintenance 3 countdown B, or maintenance 3 countdown is 0, controller will initiate an alarm signal. It is detected when the genset is running.
42	Gen Reverse Phase	When controller detects gen reverse phase sequence, it issues alarm signal; Gen reverse phase is enabled, it is detected when 3P4W or 2P3W phase voltage is over 30V, 3P3W wire voltage is over 50V;
43	Gen Loss of Phase	When controller detects gen loss of phase, it issues an alarm signal; Gen loss of phase is enabled, it is detected when 3P4W or 2P3W phase voltage is over 30V, 3P3W wire voltage is over 50V;
44	Digital Input Alarm	When the digital input port is set users-defined and if it is active, the controller will initiate an alarm signal for the input port. It is detected in the detection range set for the input port.
45	PLC Functions Alarm	When PLC function is set users-defined and if it is active, the controller will initiate an alarm signal. It is detected in the detection range set by the PLC function.
46	DIN16 Comm. Fail	When DIN16 communication is enabled and the controller cannot receive the communication data, it will initiate an alarm signal. It is always detected.
47	DIN16 Input Alarm	When DIN16 input is set users-defined and if it is active, the controller will initiate an alarm signal. It is detected in the detection range set in the input.
48	DOU16 Comm. Fail	When DOU16 communication is enabled and the controller cannot

No	Type	Description
		receive the communication data, it will initiate an alarm signal. It is always detected.
49	AIN24 Comm. Fail	When AIN24 communication is enabled and the controller cannot receive the communication data, it will initiate an alarm signal. It is always detected.
50	AIN24 Cylinder Temp. High	When this is enabled and the controller detects cylinder temperature has exceeded the pre-set value, it will initiate an alarm signal. It is detected after "safety on time" before "ETS solenoid hold".
51	AIN24 Exhaust Temp. High	When this is enabled and the controller detects exhaust temperature has exceeded the pre-set value, it will initiate an alarm signal. It is detected after "safety on time" before "ETS solenoid hold".
52	AIN24 Cylinder Temp. Difference High	When this is enabled and the controller detects cylinder temp. difference has exceeded the pre-set value, it will initiate an alarm signal. It is detected after "safety on time" before "ETS solenoid hold".
53	AIN24 Sensor Open	When the controller detects the sensor circuit is open, it shall issue an alarm signal. It is always detected.
54	AIN24 Sensor High	When over high alarm is enabled, and the controller detects the sensor value is above the preset upper limit, it shall issue an alarm signal. It is detected after "safety on time" before "ETS solenoid hold" when the sensor is selected as temperature sensor and pressure sensor; It is always detected when the sensor is selected as fuel level sensor.
55	AIN24 Sensor Low	When over low alarm is enabled, and the controller detects the sensor value is below the preset lower limit, it shall issue an alarm signal. It is detected after "safety on time" before "ETS solenoid hold" when the sensor is selected as temperature sensor and pressure sensor; It is always detected when the sensor is selected as fuel level sensor.
56	Power Factor Low	When this is enabled and the controller detects that the generator power factor has fallen below the pre-set limit, it will initiate an alarm signal. It is always detected.
57	THD High	When this is enabled and the controller detects that the THD has exceeded the pre-set limit, it will initiate an alarm signal. It is always detected.
58	Gen Volt Unbalance	When this is enabled and the controller detects that the voltage unbalanced value has exceeded the pre-set limit, it will initiate an alarm signal. It is always detected.
59	AIN16-M02 Comm. Fail	When AIN16-M02 is enabled, and when controller cannot receive the communication data of AIN16-M02 module, controller issues an alarm signal; It is always detected.
60	AIN16-M02 Sensor	When controller detects sensor is open, controller issues an alarm

No	Type	Description
	Open	signal; It is always detected.
61	AIN16-M02 Sensor High	When over high alarm is enabled, and the controller detects the sensor value is above the preset upper limit, it shall issue an alarm. It is detected after "safety on time" before "ETS solenoid hold" when the sensor is selected as temperature sensor and pressure sensor; It is always detected when the sensor is selected as fuel level sensor.
62	AIN16-M02 Sensor Low	When over low alarm is enabled, and the controller detects the sensor value is below the preset lower limit, it shall issue an alarm. It is detected after "safety on time" before "ETS solenoid hold" when the sensor is selected as temperature sensor and pressure sensor; It is always detected when the sensor is selected as fuel level sensor.
63	AIN8 Comm. Fail	AIN8 enabled; when controller cannot receive AIN8 module communication data, it will issue alarm signal; It is always detected.
64	AIN8 Sensor Open	When controller detects sensor open, it issues alarm signal; It is always detected.
65	AIN8 Sensor High	Enabled; when the sensor value detected by the controller is over the pre-set upper limit, controller issues alarm signal; When sensor type selects temp sensor and pressure sensor, it is detected after "safety on time" before "ETS solenoid hold"; It is detected always when sensor type selects liquid level sensor.
66	AIN8 Sensor Low	Enabled; when the sensor value detected by the controller is below the pre-set lower limit, controller issues alarm signal; When sensor type selects temp sensor and pressure sensor, it is detected after "safety on time" before "ETS solenoid hold"; It is detected always when sensor type selects liquid level sensor.
67	BAC150CAN Comm. Fail	When BAC150CAN is enabled, and when controller cannot receive communication data of BAC150CAN module, controller issues an alarm signal; It is always detected.

7 WIRING CONNECTION

HGM9420N\_HGM9420LT controller back panel is as below:

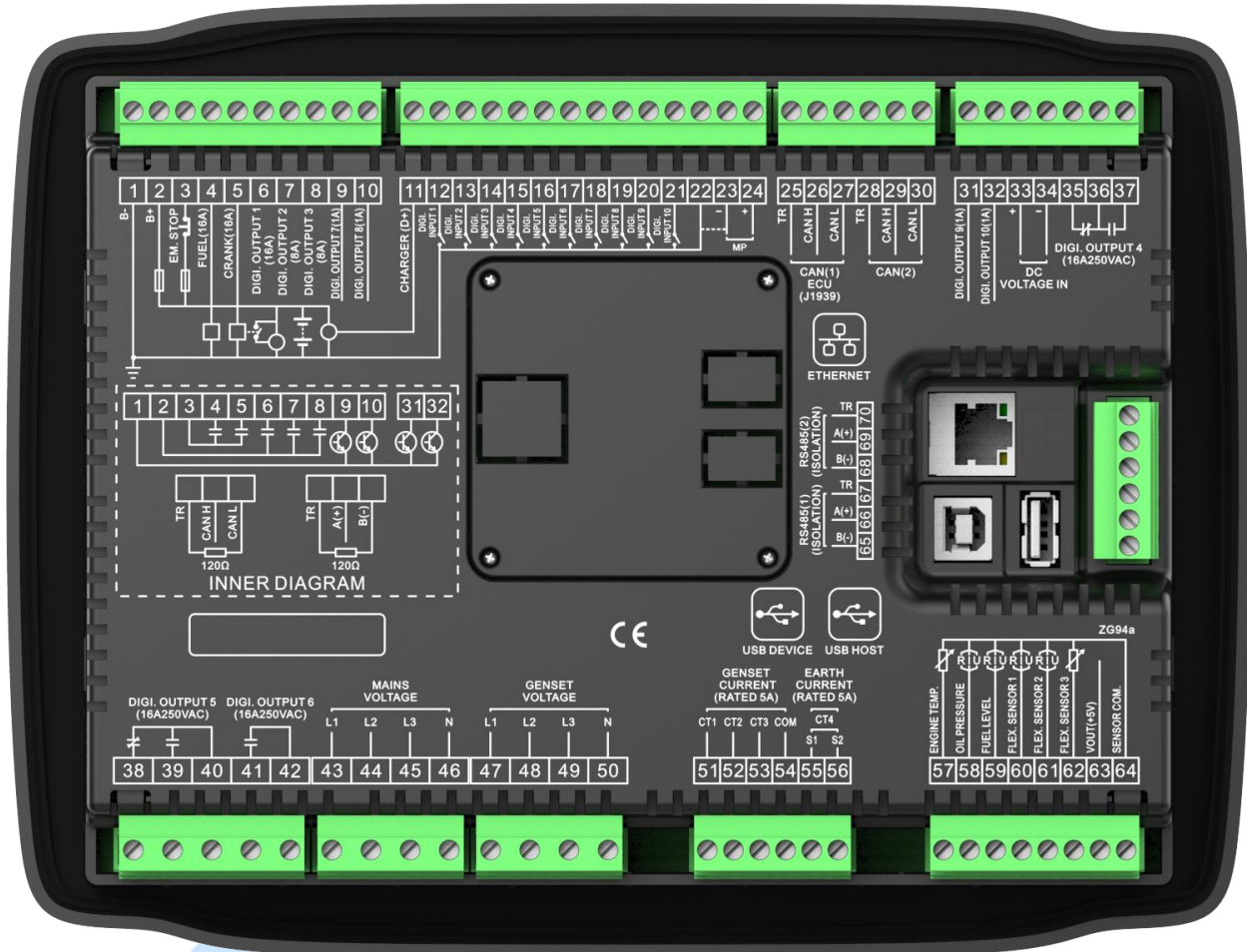

Fig. 4 Controller Back Panel

Table 12 Terminal Connection Description

No.	Functions	Cable Size	Remark
1	B-	2.5mm <sup>2</sup>	Connect with starter battery negative.
2	B+	2.5mm <sup>2</sup>	Connect with starter battery positive. If wire length is over 30m, it's better to double wires in parallel. Max. 20A fuse is recommended.
3	Emergency Stop Input	2.5mm <sup>2</sup>	Connect with B+ via emergency stop button.
4	Fuel Relay Output	1.5mm <sup>2</sup>	B+ is supplied by 3 points, rated 16A.
5	Crank Relay Output	1.5mm <sup>2</sup>	B+ is supplied by 3 points, rated 16A. Connect to starter coil.
6	Digi. Output 1	1.5mm <sup>2</sup>	B+ is supplied by 2 points, rated 16A.
7	Digi. Output 2	1.5mm <sup>2</sup>	B+ is supplied by 2 points, rated 8A.
8	Digi. Output 3	1.5mm <sup>2</sup>	B+ is supplied by 2 points, rated 8A.
9	Digi. Output 7	1.5mm <sup>2</sup>	DC30V supply (negative) output (transistor), rated 1A.
10	Digi. Output 8	1.5mm <sup>2</sup>	DC30V supply (negative) output (transistor), rated 1A.

No.	Functions	Cable Size	Remark
11	Charger (D+)	1.0mm <sup>2</sup>	Connect with Charger D+ (WL) terminal. If this terminal doesn't exist, hang it in the air.
12	Digi. Input 1	1.0mm <sup>2</sup>	Ground connected is active (B-).
13	Digi. Input 2	1.0mm <sup>2</sup>	Ground connected is active (B-).
14	Digi. Input 3	1.0mm <sup>2</sup>	Ground connected is active (B-).
15	Digi. Input 4	1.0mm <sup>2</sup>	Ground connected is active (B-).
16	Digi. Input 5	1.0mm <sup>2</sup>	Ground connected is active (B-).
17	Digi. Input 6	1.0mm <sup>2</sup>	Ground connected is active (B-).
18	Digi. Input 7	1.0mm <sup>2</sup>	Ground connected is active (B-).
19	Digi. Input 8	1.0mm <sup>2</sup>	Ground connected is active (B-).
20	Digi. Input 9	1.0mm <sup>2</sup>	Ground connected is active (B-).
21	Digi. Input 10	1.0mm <sup>2</sup>	Ground connected is active (B-).
22	Magnetic pickup shield	0.5mm <sup>2</sup>	Connect with speed sensor, and shielding line is recommended. B- is already connected with speed sensor input 2 inside controller.
23	MP2		
24	MP1		
25	ECU TR	/	Impedance-120Ω shielding wire is recommended, and the single-end shall be earth connected. Short connect TR with H and then connect to 120Ω terminal resistor.
26	ECU CAN H	0.5mm <sup>2</sup>	
27	ECU CAN L	0.5mm <sup>2</sup>	
28	CAN(2) TR	/	Impedance-120Ω shielding wire is recommended, and the single-end shall be earth connected. Short connect TR with H and then connect to 120Ω terminal resistor.
29	CAN(2) CAN H	0.5mm <sup>2</sup>	
30	CAN(2) CAN L	0.5mm <sup>2</sup>	
31	Digi. Output 9	1.5mm <sup>2</sup>	DC 30V supply (negative) output (transistor), rated 1A.
32	Digi. Output 10	1.5mm <sup>2</sup>	DC 30V supply (negative) output (transistor), rated 1A.
33	DC Voltage In +	1.0mm <sup>2</sup>	Connect DC battery pack externally.
34	DC Voltage In -	1.0mm <sup>2</sup>	
35	Digi. Output 4	2.5mm <sup>2</sup>	Normally close output, rated 16A.
36			Public points of relay.
37			Normally open output, rated 16A.
38	Digi. Output 5	2.5mm <sup>2</sup>	Normally close output, rated 16A.
39			Public points of relay.
40			Normally open output, rated 16A.
41	Digi. Output 6	2.5mm <sup>2</sup>	Normally open output, rated 16A.
42			Public points of relay.
43	Mains L1 Phase Voltage Input	1.0mm <sup>2</sup>	Connect to Mains L1 Phase (2A fuse is recommended).
44	Mains L2 Phase Voltage Input	1.0mm <sup>2</sup>	Connect to Mains L2 Phase (2A fuse is recommended).
45	Mains L3 Phase Voltage Input	1.0mm <sup>2</sup>	Connect to Mains L3 Phase (2A fuse is recommended).
46	Mains N Wire Input	1.0mm <sup>2</sup>	Connect to Mains N wire.
47	Gen L1 Phase Voltage Input	1.0mm <sup>2</sup>	Connect to Gen L1 Phase (2A fuse is recommended).

No.	Functions	Cable Size	Remark
48	Gen L2 Phase Voltage Input	1.0mm <sup>2</sup>	Connect to Gen L2 Phase (2A fuse is recommended).
49	Gen L3 Phase Voltage Input	1.0mm <sup>2</sup>	Connect to Gen L3 Phase (2A fuse is recommended).
50	Gen N Wire Input	1.0mm <sup>2</sup>	Connect to Gen N wire.
51	CT A-phase Input	1.5mm <sup>2</sup>	Connect to CT secondary coil (rated 5A) externally.
52	CT B-phase Input	1.5mm <sup>2</sup>	Connect to CT secondary coil (rated 5A) externally.
53	CT C-phase Input	1.5mm <sup>2</sup>	Connect to CT secondary coil (rated 5A) externally.
54	CT COM	1.5mm <sup>2</sup>	Please refer to following installation illustration.
55	Earth CT Input	1.5mm <sup>2</sup>	Outside connect to CT secondary coil (rated 5A).
56		1.5mm <sup>2</sup>	
57	Engine Temp. Sensor	1.0mm <sup>2</sup>	Connect to temperature resistance sensor.
58	Oil Pressure Sensor	1.0mm <sup>2</sup>	Connect to engine oil pressure sensor. Voltage type (0V-10V), current type (4mA-20mA) and resistance sensor can be chosen.
59	Fuel Level Sensor	1.0mm <sup>2</sup>	Connect to fuel level resistance sensor. Voltage type (0V-10V), current type (4mA-20mA) and resistance sensor can be chosen.
60	Flex. Sensor 1	1.0mm <sup>2</sup>	Connect to temp./fuel level/pressure type sensor. Voltage type (0V-10V), current type (4mA-20mA) and resistance sensor can be chosen.
61	Flex. Sensor 2	1.0mm <sup>2</sup>	Connect to temp./fuel level/pressure type sensor. Voltage type (0V-10V), current type (4mA-20mA) and resistance sensor can be chosen.
62	Flex. Sensor 3	1.0mm <sup>2</sup>	Connect to temp./fuel level/pressure resistance sensor.
63	VOUT(+5V)	1.0mm <sup>2</sup>	Provide +5V voltage for voltage type sensor, and current is below 50mA.
64	Sensor COM.	/	Public sensor terminal, and battery negative is already connected in the controller.
65	RS485(1) B(-)	0.5mm <sup>2</sup>	Impedance-120Ω shielding wire is recommended, and the single-end shall be earth connected. Short connect TR with A(+) and then connect to 120Ω terminal resistor.
66	RS485(1) A(+)	0.5mm <sup>2</sup>	
67	RS485(1) TR	/	
68	RS485(2) B(-)	0.5mm <sup>2</sup>	Impedance-120Ω shielding wire is recommended, and the single-end shall be earth connected. Short connect TR with A(+) and then connect to 120Ω terminal resistor.
69	RS485(2) A(+)	0.5mm <sup>2</sup>	
70	RS485(2) TR	/	

**NOTE 1:** The slave USB ports on the controller rear panel are configurable parameter ports, and users can directly program the controller on PC.

**NOTE 2:** The master USB port on the controller rear panel is U flash, by which controller parameters can be lead in or export out.

**NOTE 3:** Expansion SGE02-4G module can be inserted on the back panel.

8 SCOPES AND DEFINITIONS OF PROGRAMMABLE PARAMETERS

8.1 CONTENTS AND SCOPES OF PARAMETERS

Table 13 Parameter Configuration Contents and Scopes

No.	Items	Parameters	Defaults	Description
Module Setting				
1.	Power On Mode	(0-2)	0	0: Stop Mode 1: Manual Mode 2: Auto Mode
2.	Module Address	(1-254)	1	Controller address for remote monitoring
3.	Language	(0-2)	0	0: Simplified Chinese 1: English 2: Other
4.	Password	(0-65535)	00318	It is used to enter advanced parameter setting.
5.	Daylight Saving Time	(0-1)	0	0: Disable 1: Enable Start and end time for this can be set.
6.	Date and Time			It is used for date and time settings.
7.	Temperature Unit	(0-1)	0	0: °C; 1: °F
8.	Pressure Unit	(0-2)	0	0: kPa 1: psi 2: bar
9.	Backlight Time	(0-3600)s	300	
10.	Network	(0-1)	1	0: Disable 1: Enable
11.	J1939-75	(0-1)	0	0: Disable 1: Enable
12.	Alarm Data Interval	(0-60.0)s	0.1	
13.	Custom Protocol	(0-1)	0	0: Disable 1: Enable
14.	Fn Function	(0-6)	0	0: Fn Key 1: Stop Key 2: Start Key 3: Manual Key 4: Auto Key 5: Mains Close/Open Key 6: Gen Close/Open Key
Mains Setting				
1.	Mains Options	(0-2)	1	0: Disable; 1: AMF; 2: Only Indication
2.	AC System	(0-3)	0	0: 3P4W 1: 3P3W 2: 2P3W 3: 1P2W
3.	Normal Delay	(0-3600)s	10	Check time from Mains abnormal to normal;
4.	Abnormal Delay	(0-3600)s	5	Check time from Mains normal to abnormal;

No.	Items	Parameters	Defaults	Description
5.	Loss of Phase	(0-1)	1	0: Disable; 1: Enable
6.	Reverse Phase Seq.	(0-1)	1	0: Disable; 1: Enable
7.	Rated Voltage	(30-30000)V	230	Provide standards for Mains over voltage and under voltage; if PT is fitted, this value is primary voltage of PT.
8.	PT Fitted	(0-1)	0	0: Disable; 1: Enable
		(30-30000)V	100	Mains primary voltage.
		(30-1000)V	100	Mains secondary voltage.
9.	Over Voltage	(0-1)	1	Set value is percentage of Mains rated voltage; Return and delay value can also be set.
		(0-200.0)%	120.0	
		(0-200.0)%	116.0	
		(0-3600)s	5	
10.	Under Voltage	(0-1)	1	
		(0-200.0)%	80.0	
		(0-200.0)%	84.0	
		(0-3600)s	5	
11.	Rated Frequency	(10.0-75.0)Hz	50.0	Provide standards for Mains over frequency and under frequency.
12.	Over Frequency	(0-1)	0	Set value is percentage of Mains rated frequency; Return value and delay value can also be set.
		(0-200.0)%	114.0	
		(0-200.0)%	110.0	
		(0-3600)s	5	
13.	Under Frequency	(0-1)	0	
		(0-200.0)%	90.0	
		(0-200.0)%	94.0	
		(0-3600)s	5	
<b>Timer Setting</b>				
1.	Start Delay	(0-3600)s	5	Time from mains abnormal or remote start signal is active to genset is starting.
2.	Stop Delay	(0-3600)s	30	Time from mains normal or remote start signal is inactive to genset is stopping.
3.	Pre-heat Delay	(0-3600)s	0	Time for pre-powering the heat plug before starter is powered up.
4.	Fuel Time	(1-3600)s	1	Fuel output time before crank output.
5.	Cranking Time	(3-60)s	8	Time for starter power on each time.
6.	Crank Rest Time	(3-60)s	10	The waiting time before second power up when engine start fails.
7.	Safety On Time	(0-3600)s	10	Alarms for low oil pressure, high temperature, under speed, under frequency /voltage, charging failure are inactive.
8.	Start Idle Time	(0-3600)s	10	Running time for genset idling speed when the genset is starting.

No.	Items	Parameters	Defaults	Description
9.	Warming Up Time	(0-3600)s	30	Warming up time between genset switch on and high speed running.
10.	Cooling Time	(0-3600)s	60	Radiating time before genset stop, after it unloads.
11.	Stop Idle Time	(0-3600)s	10	Running time for genset idling speed when the genset is stopping.
12.	ETS Hold Time	(0-3600)s	20	Time for the stop electromagnet energization as the genset is stopping.
13.	Fail to Stop	(0-3600)s	0	Time after "idle delay" is over before the complete stop when "ETS Hold Time" is set "0"; time after "ETS Hold Time" delay is over before the complete stop when it is set other than "0".
14.	After Stop Time	(0-3600)s	0	Time between a complete stop and standby.
15.	Gas Engine Timers	(0-1)	0	0: Disable 1: Enable
16.	Choke On Time	(0-60)s	0	Output time for gas thickening after the unit starts.
17.	Gas On Delay	(0-60)s	0	
18.	Ignition Off	(0-60)s	0	
19.	Smart Pre-heat	(0-1) (0-2) (0-300)°C	0 0 40	0: Disable 1: Enable When it is enabled, the controller will stop pre-heating earlier according to the set conditions. Sensors are available, and when it is above the set value, it shall end the pre-heating.
20.	Smart Start Idle	(0-1) (0-2) (0-300)°C	0 0 50	0: Disable 1: Enable When it is enabled, the controller will stop pre-heating earlier according to the set conditions. Sensors are available, and when it is above the set value, it shall end start idle process.
<b>Engine Setting</b>				
1.	Engine Type	(0-39)	0	Default: non-ECU engine
2.	Flywheel Teeth	(10-300)	118	Tooth number of the engine, for judging of starter separation conditions and inspecting of engine speed. See following installation instructions.
3.	Rated Speed	(0-6000)r/min	1500	Offer standard to judge over/under/loading speed.
4.	Loading Speed	(0-100.0)%	90.0	Set value is percentage of rated speed. Controller detects when it is ready to load. It won't enter normal running period when

No.	Items	Parameters	Defaults	Description
				speed is under loading speed.
5.	Start Attempts	(1-10)times	3	Maximum start times for start failures; when it reaches up to the set value, controller will issue failed to start signal.
6.	Disc. Condition	(0-6)	2	Please refer to Table 17. 3 kinds of conditions for starter and engine separation; and they can be used separately, or used simultaneously in order to separate motor and engine as soon as possible.
7.	Disconnect Freq	(0-200.0)%	24.0	Set value is gen rated frequency percentage; when gen freq. is above pre-set value, starter will separate; Please refer to following installation illustration.
8.	Disconnect Speed	(0-200.0)%	24.0	Set value is rated speed percentage; when speed is above pre-set value, starter will separate; Please refer to following installation illustration.
9.	Disconnect OP	(0-1000)kPa	200	When engine oil pressure is above pre-set value, starter will separate; Please refer to following installation illustration.
10.	ECU Fault Lamp	(0-5)	1	0: None; 1: Warning; 2: Block; 3: Trip; 4: Trip and Stop; 5: Shutdown
11.	ECU Stop Lamp	(0-5)	5	
12.	ECU Warning Lamp	(0-5)	1	
13.	ECU Protect Lamp	(0-5)	1	
14.	Battery Voltage	(0-60.0)V	24.0	Provide standards for battery over voltage and under voltage.
15.	Battery Over Volt. 1	(0-1)	1	0: Disable 1: Enable
		(0-200.0)%	120.0	Set value is batt. rated volt percentage.
		(0-200.0)%	115.0	Return value is batt. rated volt percentage.
		(0-3600)s	60	Delay value
16.	Battery Over Volt. 2	(0-1)	0	0: Disable 1: Enable
		(0-200.0)%	120.0	Set value is batt. rated volt percentage.
		(0-200.0)%	115.0	Return value is batt. rated volt percentage.
		(0-3600)s	60	Delay value
17.	Battery Under Volt. 1	(0-1)	1	0: Disable 1: Enable
		(0-200.0)%	85.0	Set value is batt. rated volt percentage.
		(0-200.0)%	90.0	Return value is batt. rated volt percentage.
		(0-3600)s	60	Delay value
18.	Battery Under Volt. 2	(0-1)	0	0: Disable 1: Enable
		(0-200.0)%	85.0	Set value is batt. rated volt percentage.
		(0-200.0)%	90.0	Return value is batt. rated volt percentage.
		(0-3600)s	60	Delay value
18.	Battery Under Volt. 2	(0-1)	0	0: Disable 1: Enable
		(0-200.0)%	85.0	Set value is batt. rated volt percentage.
		(0-200.0)%	90.0	Return value is batt. rated volt percentage.
		(0-3600)s	60	Delay value

No.	Items	Parameters	Defaults	Description
		(0-200.0)% (0-200.0)% (0-3600)s (0-5)	85.0 90.0 60 0	Set value is batt. rated volt percentage. Return value is batt. rated volt percentage. Delay value Action
19.	Charge Alt Failure	(0-1) (0-60.0)V (0-60.0)V (0-3600)s (0-5)	1 8.0 10.0 10 1	0: Disable    1: Enable Set Value Return Value Delay Value Action
20.	DC Volt. Start	(0-1) (0-60.0)V (0-60.0)V (0-3600)s	0 46.6 53.8 60	0: Disable    1: Enable Start Value Stop Value Delay Value
21.	Over Speed 1	(0-1) (0-200.0)% (0-200.0)% (0-3600)s (0-5)	1 114.0 112.0 2 5	0: Disable    1: Enable Set value is rated speed percentage; Return value is rated speed percentage; Delay value Action
22.	Over Speed 2	(0-1) (0-200.0)% (0-200.0)% (0-3600)s (0-5)	1 110.0 108.0 5 1	0: Disable    1: Enable Set value is rated speed percentage; Return value is rated speed percentage; Delay value Action
23.	Under Speed 1	(0-1) (0-200.0)% (0-200.0)% (0-3600)s (0-5)	1 80.0 82.0 3 5	0: Disable    1: Enable Set value is rated speed percentage; Return value is rated speed percentage; Delay value Action
24.	Under Speed 2	(0-1) (0-200.0)% (0-200.0)% (0-3600)s (0-5)	1 86.0 90.0 5 1	0: Disable    1: Enable Set value is rated speed percentage; Return value is rated speed percentage; Delay value Action
25.	Loss of Speed Signal Action	(0-5)	5	0: None; 1: Warning; 2: Block; 3: Trip; 4: Trip and Stop; 5: Shutdown
26.	Loss of Speed Signal Delay	(0-3600)s	5	Time from detecting speed is 0 to action confirm.
<b>Generator Setting</b>				
1.	AC System	(0-3)	0	0: 3P4W; 1: 3P3W; 2: 2P3W; 3: 1P2W.
2.	Poles	(2-64)	4	Numbers of generator poles; this value is used for engine speed calculation when speed sensor is not installed.

No.	Items	Parameters	Defaults	Description
3.	Rated Voltage	(30-30000)V	230	Provide standards for judging gen over voltage, under voltage and loading voltage. If PT is fitted, this is primary voltage of PT; when AC system is 3P3W, this value is wire voltage; for other AC systems, this value is phase voltage.
4.	Loading Voltage	(0-200.0)%	85.0	Set value is rated voltage percentage; controller detected when it prepares to take load; when gen voltage is less than loading voltage, genset won't enter normal running period.
5.	Rated Frequency	(10.0-75.0)Hz	50.0	Offer standards for detecting over/under/loading frequency.
6.	Loading Frequency	(0-200.0)%	85.0	Percentage of generator rated frequency; controller detects when it prepares to take load; when gen frequency is less than loading frequency, it won't enter normal running period.
7.	PT Fitted	(0-1)	0	0: Disable 1: Enable
8.	Harmonic Display	(0-1)	0	0: Disable 1: Enable
9.	Loss of Phase	(0-1)	1	0: Disable 1: Enable
10.	Reverse Phase Seq.	(0-1)	1	0: Disable 1: Enable
11.	Over Volt 1	(0-1) (0-200.0)% (0-200.0)% (0-3600)s (0-5)	1 120.0 118.0 3 5	0: Disable 1: Enable Set value is gen rated voltage percentage; Return value is gen rated voltage percentage; Delay value Action
12.	Over Volt 2	(0-1) (0-200.0)% (0-200.0)% (0-3600)s (0-5)	1 110.0 108.0 5 1	0: Disable 1: Enable Set value is gen rated voltage percentage; Return value is gen rated voltage percentage. Delay value Action
13.	Under Volt 1	(0-1) (0-200.0)% (0-200.0)% (0-3600)s (0-5)	1 80.0 82.0 3 5	0: Disable 1: Enable Set value is gen rated voltage percentage; Return value is gen rated voltage percentage. Delay value Action
14.	Under Volt 2	(0-1) (0-200.0)% (0-200.0)%	1 84.0 86.0	0: Disable 1: Enable Set value is gen rated voltage percentage; Return value is gen rated voltage

No.	Items	Parameters	Defaults	Description
		(0-3600)s (0-5)	5 1	percentage. Delay value Action
15.	Volt Imbalance 1	(0-1) (0-200.0)% (0-200.0)% (0-3600)s (0-5)	1 10.0 5.0 5 1	0: Disable 1: Enable Set value is degree of unbalance of gen voltage. Return value is degree of unbalance of gen voltage. Delay value Action
16.	Volt Imbalance 2	(0-1) (0-200.0)% (0-200.0)% (0-3600)s (0-5)	0 10.0 5.0 5 0	0: Disable 1: Enable Set value is gen degree of unbalance. Return value is gen degree of unbalance. Delay value Action
17.	THD Alarm 1	(0-1) (0-200.0)% (0-200.0)% (0-3600)s (0-5)	0 10.0 5.0 5 0	0: Disable 1: Enable Set value is degree of distortion of gen voltage. Return value is degree of distortion of gen voltage. Delay value Action
18.	THD Alarm 2	(0-1) (0-200.0)% (0-200.0)% (0-3600)s (0-5)	0 10.0 5.0 5 0	0: Disable 1: Enable Set value is degree of distortion of gen voltage. Return value is degree of distortion of gen voltage. Delay value Action
19.	Over Freq. 1	(0-1) (0-200.0)% (0-200.0)% (0-3600)s (0-5)	1 114.0 112.0 2 5	0: Disable 1: Enable Set value is gen rated frequency percentage. Return value is gen rated frequency percentage. Delay value Action
20.	Over Freq. 2	(0-1) (0-200.0)% (0-200.0)% (0-3600)s (0-5)	1 110.0 108.0 5 1	0: Disable 1: Enable Set value is gen rated frequency percentage. Return value is gen rated frequency percentage. Delay value Action

No.	Items	Parameters	Defaults	Description
21.	Under Freq. 1	(0-1) (0-200.0)% (0-200.0)% (0-3600)s (0-5)	1 80.0 82.0 3 5	0: Disable 1: Enable Set value is gen rated frequency percentage. Return value is gen rated frequency percentage. Delay value Action
22.	Under Freq. 2	(0-1) (0-200.0)% (0-200.0)% (0-3600)s (0-5)	1 84.0 86.0 5 1	0: Disable 1: Enable Set value is gen rated frequency percentage. Return value is gen rated frequency percentage. Delay value Action
<b>Load Setting</b>				
1.	CT Ratio	(5-6000)/5	500	Ratio of external connected current transformer.
2.	Rated Current	(5-6000)A	500	It is rated current of generator and used for loading current standard.
3.	CT Position	(0-1)	0	0: Load; 1: Gen
4.	Over Current 1	(0-1) (0-200.0)% (0-200.0)% (0-3600)s (0-5)	1 120.0 118.0 3 4	0: Disable 1: Enable Set value is percentage of rated current. Return value is percentage of rated current. Delay value Action
5.	Over Current 2	(0-1) (0-200.0)% (0-200.0)% (0-3600)s (0-5)	1 110.0 108.0 5 1	0: Disable 1: Enable Set value is percentage of rated current. Return value is percentage of rated current. Delay value Action
6.	Unbalance Current 1	(0-1) (0-200.0)% (0-200.0)% (0-3600)s (0-5)	1 20.0 18.0 5 1	0: Disable 1: Enable Set value is percentage of rated current. Return value is percentage of rated current. Delay value Action
7.	Unbalance Current 2	(0-1) (0-200.0)% (0-200.0)% (0-3600)s (0-5)	0 20.0 18.0 5 0	0: Disable 1: Enable Set value is percentage of rated current. Return value is percentage of rated current. Delay value Action
8.	Earth Fault 1	(0-1) (0-200.0)% (0-200.0)%	1 20.0 18.0	0: Disable 1: Enable Set value is percentage of rated current. Return value is percentage of rated current.

No.	Items	Parameters	Defaults	Description
		(0-3600)s (0-5)	5 1	Delay value Action
9.	Earth Fault 2	(0-1) (0-200.0)% (0-200.0)% (0-3600)s (0-5)	0 20.0 18.0 5 0	0: Disable 1: Enable Set value is percentage of rated current. Return value is percentage of rated current. Delay value Action
10.	Rated Power(kW)	(0-6000)kW	276	Genset rated active power, which is standard of loading active power.
11.	Rated Power(kvar)	(0-6000)kvar	210	Genset rated reactive power, which is standard of loading reactive power.
12.	Reverse Power 1	(0-1) (0-200.0)% (0-200.0)% (0-3600)s (0-5)	1 10.0 8.0 3 5	0: Disable 1: Enable Set value is percentage of rated active power. Return value is percentage of rated active power. Delay value Action
13.	Reverse Power 2	(0-1) (0-200.0)% (0-200.0)% (0-3600)s (0-5)	1 5.0 3.0 5 1	0: Disable 1: Enable Set value is percentage of rated active power. Return value is percentage of rated active power. Delay value Action
14.	Over Power 1	(0-1) (0-200.0)% (0-200.0)% (0-3600)s (0-5)	1 120.0 118.0 3 5	0: Disable 1: Enable Set value is percentage of rated active power. Return value is percentage of rated active power. Delay value Action
15.	Over Power 2	(0-1) (0-200.0)% (0-200.0)% (0-3600)s (0-5)	1 110.0 108.0 5 1	0: Disable 1: Enable Set value is percentage of rated active power. Return value is percentage of rated active power. Delay value Action
16.	Loss Excitation 1	(0-1) (0-200.0)% (0-200.0)% (0-3600)s	1 20.0 18.0 5	0: Disable 1: Enable Set value is percentage of rated reactive power. Return value is percentage of rated reactive

No.	Items	Parameters	Defaults	Description
		(0-5)	1	power. Delay value Action
17.	Loss Excitation 2	(0-1) (0-200.0)% (0-200.0)% (0-3600)s (0-5)	0 20.0 18.0 5 0	0: Disable    1: Enable Set value is percentage of rated reactive power. Return value is percentage of rated reactive power. Delay value Action
18.	PF Low 1	(0-1) (0-1.00) (0-1.00) (0-3600)s (0-5)	1 0.70 0.75 5 1	0: Disable    1: Enable Set value is gen power factor. Return value is gen power factor. Delay value Action
19.	PF Low 2	(0-1) (0-1.00) (0-1.00) (0-3600)s (0-5)	0 0.70 0.75 5 0	0: Disable    1: Enable Set value is gen power factor. Return value is gen power factor. Delay value Action
<b>Switch Setting</b>				
1.	Close Time	(0-20.0)s	5.0	Pulse width of switch on. When it is 0, it means output constantly.
2.	Open Time	(0-20.0)s	3.0	Pulse width of switch off.
3.	Check Time	(0-20.0)s	5.0	After ATS transfer, check time for switch auxiliary contact.
4.	Open Check Enable	(0-1)	0	0: Disable;    1: Enable
5.	Transfer Fail Warn	(0-1)	0	Interval time from Mains open to Gen close or from Gen open to Mains close.
6.	Transfer Time	(0-7200)s	5	
7.	Mains Abnormal Trip	(0-1)	1	0: Disable;    1: Enable
<b>Analog Sensor Setting</b>				
<b>Temperature Sensor</b>				
1.	Curve Type	(0-15)	8	SGD; For details please see Table 16.
2.	Open Act	(0-5)	1	0: None; 1: Warning; 2: Block; 3: Trip; 4: Trip and Stop; 5: Shutdown.
3.	Over Alarm 1	(0-1)	1	0: Disable    1: Enable
		((-50)-300)°C	98	Set value is engine temperature value.
		((-50)-300)°C	96	Set value is engine temperature value.
		(0-3600)s	3	Delay value
(0-5)	5	Action		
4.	Over Alarm 2	(0-1)	1	0: Disable    1: Enable
		((-50)-300)°C	95	Set value is engine temperature value.
		((-50)-300)°C	93	Set value is engine temperature value.

No.	Items	Parameters	Defaults	Description
		(0-3600)s	5	Delay value
		(0-5)	1	Action
5.	Under Alarm	(0-1)	0	0: Disable 1: Enable
		((-50)-300)°C	70	Set value is engine temperature value.
		((-50)-300)°C	75	Set value is engine temperature value.
		(0-3600)s	5	Delay value
		(0-5)	1	Action
6.	Custom Curve			
Oil Pressure Sensor				
1.	Curve Type	(0-15)	8	SGD; For details please see Table 16.
2.	Open Act	(0-5)	1	0: None; 1: Warning; 2: Block; 3: Trip; 4: Trip and Stop; 5: Shutdown.
3.	Under Alarm 1	(0-1)	1	0: Disable 1: Enable
		(0-1000)kPa	103	Set value is engine oil pressure value.
		(0-1000)kPa	117	Set value is engine oil pressure value.
		(0-3600)s	2	Delay value
		(0-5)	5	Action
4.	Under Alarm 2	(0-1)	1	0: Disable 1: Enable
		(0-1000)kPa	124	Set value is engine oil pressure value.
		(0-1000)kPa	138	Set value is engine oil pressure value.
		(0-3600)s	5	Delay value
		(0-5)	1	Action
5.	Custom Curve			
Fuel Level Sensor				
1.	Curve Type	(0-15)	4	SGD; For details please see Table 16.
2.	Open Act	(0-5)	0	0: None; 1: Warning; 2: Block; 3: Trip; 4: Trip and Stop; 5: Shutdown.
3.	Under Alarm 1	(0-1)	1	0: Disable 1: Enable
		(0-100)%	0	Set value is engine fuel level value.
		(0-100)%	5	Set value is engine fuel level value.
		(0-3600)s	5	Delay value
		(0-5)	5	Action
4.	Under Alarm 2	(0-1)	1	0: Disable 1: Enable
		(0-100)%	10	Set value is engine fuel level value.
		(0-100)%	15	Set value is engine fuel level value.
		(0-3600)s	5	Delay value
		(0-5)	1	Action
5.	Custom Curve			
6.	Fuel Tank Volume	(0-1)	0	0: Disable 1: Enable
		(0-10000)L	1000	Engine fuel volume value.
7.	Fuel Economy Enable	(0-1)	0	0: Disable 1: Enable
8.	Fuel Economy Curve			
Flexible Sensor 1				

No.	Items	Parameters	Defaults	Description
1.	Sensor Type	(0-3)	0	0: None 1: Temp Sensor 2: Pressure Sensor 3: Level Sensor
Flexible Sensor 2				
1.	Sensor Type	(0-3)	0	0: None 1: Temp Sensor 2: Pressure Sensor 3: Level Sensor
Flexible Sensor 3				
1.	Sensor Type	(0-3)	0	0: None 1: Temp Sensor 2: Pressure Sensor 3: Level Sensor
Digital Input Ports				
Digital Input Port 1				
1.	Contents Setting	(0-70)	28	Remote start (on load). For details see Table 15.
2.	Active Type	(0-1)	0	0: Close 1: Open
Digital Input Port 2				
1.	Contents Setting	(0-70)	26	Temperature high shutdown input. For details see Table 15.
2.	Active Type	(0-1)	0	0: Close 1: Open
Digital Input Port 3				
1.	Contents Setting	(0-70)	27	Low oil pressure shutdown input; For details see Table 15.
2.	Active Type	(0-1)	0	0: Close 1: Open
Digital Input Port 4				
1.	Contents Setting	(0-70)	0	User defined. For details see Table 15.
2.	Active Type	(0-1)	0	0: Close 1: Open
3.	Active Range	(0-3)	2	0: From safety on 1: From starting 2: Always 3: Never
4.	Active Actions	(0-5)	0	0: None; 1: Warning; 2: Block; 3: Trip; 4: Trip and Stop; 5: Shutdown
5.	Delay	(0-20.0)s	2.0	Time from detecting input port is active to confirm;
6.	Description			When input port is active, LCD displays the contents.
Digital Input Port 5				
1.	Contents Setting	(0-70)	0	Users-defined; For details see Table 15.
2.	Active Type	(0-1)	0	0: Close 1: Open
3.	Active Range	(0-3)	2	0: From safety on 1: From starting

No.	Items	Parameters	Defaults	Description
				2: Always 3: Never
4.	Active Actions	(0-5)	1	0: None; 1: Warning; 2: Block; 3: Trip; 4: Trip and Stop; 5: Shutdown
5.	Active Delay	(0-20.0)s	2.0	Time from detecting active to confirm
6.	Description			LCD displays detailed contents when the input is active.
<b>Digital Input Port 6</b>				
1.	Contents Setting	(0-70)	0	Users-defined; For details see Table 15.
2.	Active Type	(0-1)	0	0: Close 1: Open
3.	Active Range	(0-3)	2	0: From safety on 1: From starting 2: Always 3: Never
4.	Active Actions	(0-5)	2	0: None; 1: Warning; 2: Block; 3: Trip; 4: Trip and Stop; 5: Shutdown
5.	Active Delay	(0-20.0)s	2.0	Time from detecting active to confirm
6.	Description			LCD displays detailed contents when the input is active.
<b>Digital Input Port 7</b>				
1.	Contents Setting	(0~70)	5	Lamp test; For details see Table 15.
2.	Active Type	(0~1)	0	0: Close 1: Open
<b>Digital Input Port 8</b>				
1.	Contents Setting	(0-70)	0	User defined. For details see Table 15.
2.	Active Type	(0-1)	0	0: Close 1: Open
3.	Active Range	(0-3)	0	0: From safety on 1: From starting 2: Always 3: Never
4.	Active Actions	(0-5)	0	0: None; 1: Warning; 2: Block; 3: Trip; 4: Trip and Stop; 5: Shutdown
5.	Active Delay	(0-20.0)s	2.0	Time from detecting active to confirm.
6.	Description			LCD displays detailed contents when the input is active.
<b>Digital Input Port 9</b>				
1.	Contents Setting	(0-70)	0	Users-defined. For details see Table 15.
2.	Active Type	(0-1)	0	0: Close 1: Open
3.	Active Range	(0-3)	0	0: From safety on 1: From starting 2: Always 3: Never
4.	Active Actions	(0-5)	0	0: None; 1: Warning; 2: Block; 3: Trip; 4: Trip and Stop; 5: Shutdown
5.	Active Delay	(0-20.0)s	2.0	Time from detecting active to confirm
6.	Description			LCD displays detailed contents when the input is active.
<b>Digital Input Port 10</b>				
1.	Contents Setting	(0-70)	0	Users-defined. For details see Table 15.
2.	Active Type	(0-1)	0	0: Close 1: Open

No.	Items	Parameters	Defaults	Description
3.	Active Range	(0-3)	0	0: From safety on 1: From starting 2: Always 3: Never
4.	Active Actions	(0-5)	0	0: None; 1: Warning; 2: Block; 3: Trip; 4: Trip and Stop; 5: Shutdown
5.	Active Delay	(0-20.0)s	2.0	Time from detecting active to confirm
6.	Description			LCD displays detailed contents when the input is active.
<b>Digital Output Ports</b>				
<b>Digital Output Port 1</b>				
1.	Contents Setting	(0-299)	35	Idle speed control; For details please see Table 14.
2.	Active Type	(0-1)	0	0: Normally open; 1: Normally close
<b>Digital Output Port 2</b>				
3.	Contents Setting	(0~299)	48	Common alarm; For details please see Table 14.
4.	Active Type	(0~1)	0	0: Normally open; 1: Normally close
<b>Digital Output Port 3</b>				
1.	Contents Setting	(0~299)	38	Energize to stop; For details please see Table 14.
2.	Active Type	(0~1)	0	0: Normally open; 1: Normally close
<b>Digital Output Port 4</b>				
1.	Contents Setting	(0~299)	31	Mains close output; For details please see Table 14.
2.	Active Type	(0~1)	0	0: Normally open; 1: Normally close
<b>Digital Output Port 5</b>				
1.	Contents Setting	(0~299)	28	Open output; For details please see Table 14.
2.	Active Type	(0~1)	0	0: Normally open; 1: Normally close
<b>Digital Output Port 6</b>				
1.	Contents Setting	(0~299)	29	Gen close output; For details please see Table 14.
2.	Active Type	(0~1)	0	0: Normally open; 1: Normally close
<b>Digital Output Port 7</b>				
1.	Contents Setting	(0~299)	0	Not Used; For details please see Table 14.
2.	Active Type	(0~1)	0	0: Normally open; 1: Normally close
<b>Digital Output Port 8</b>				
1.	Contents Setting	(0~299)	0	Not Used; For details please see Table 14.
2.	Active Type	(0~1)	0	0: Normally open; 1: Normally close
<b>Digital Output Port 9</b>				
1.	Contents Setting	(0-299)	0	Not Used; For details please see Table 14.
2.	Active Type	(0-1)	0	0: Normally open; 1: Normally close
<b>Digital Output Port 10</b>				

No.	Items	Parameters	Defaults	Description
1.	Contents Setting	(0-299)	0	Not Used; For details please see Table 14.
2.	Active Type	(0-1)	0	0: Normally open; 1: Normally close
<b>Scheduled Run Setting</b>				
1	Scheduled Run	(0~1)	0	0: Disable; 1: Enable Circular setting (monthly, weekly, daily), start time setting, continuous time setting and loading selection are available.
<b>Scheduled Not Run Setting</b>				
1	Scheduled Not Run	(0~1)	0	0: Disable; 1: Enable Circular setting (monthly, weekly, daily), non-start time setting, and continuous time setting are available.
<b>Maintenance Setting</b>				
<b>Maintenance 1 Setting</b>				
1	Enable	(0-1)	0	0: Disable; 1: Enable Maintenance countdown, time due action, pre-alarm time of A and B and action can be set.
<b>Maintenance 2 Setting</b>				
1	Enable	(0-1)	0	0: Disable; 1: Enable Maintenance countdown, time due action, pre-alarm time of A and B and action can be set.
<b>Maintenance 3 Setting</b>				
1	Enable	(0-1)	0	0: Disable; 1: Enable Maintenance countdown, time due action, pre-alarm time of A and B and action can be set.
<b>Alternative Configuration</b>				
<b>Alt. Config. 1</b>				
1	Enable	(0-1)	0	0: Disable; 1: Enable Power supply system, rated voltage, rated frequency, rated speed, rated current, rated active power, rated reactive power can be set.
<b>Alt. Config. 2</b>				
2	Enable	(0-1)	0	0: Disable; 1: Enable Power supply system, rated voltage, rated frequency, rated speed, rated current, rated active power, rated reactive power can be set.
<b>Alt. Config. 3</b>				
3	Enable	(0-1)	0	0: Disable; 1: Enable

No.	Items	Parameters	Defaults	Description
				Power supply system, rated voltage, rated frequency, rated speed, rated current, rated active power, rated reactive power can be set.
<b>Cycle Start Setting</b>				
1.	Cycle Start Enabled	(0-1)	0	0: Disable; 1: Enable
2.	Priority Selection	(0-1)	0	0: Backup (slave); 1: Master
3.	Master Run Time (min)	(0-1440)	720	When enabled, it is master running time,
4.	Backup Run Time (min)	(0-1440)	720	When enabled, it is backup running time.
5.	Comm. Port	(0-1)	0	0: CAN(2); 1: RS485(2)
<b>Sync Setting</b>				
<b>Sync Check</b>				
1.	Check Enable	(0-1)	0	0: Disable; 1: Enable
2.	Check Volt Diff.	(0-30)V	3	Voltage difference of Gen and Mains; if it is below sync volt difference, then volt sync is considered.
3.	Check Pos Freq Diff.	(0-2.00)Hz	0.20	Freq difference of Gen and Mains; if it is below positive difference of sync, and above negative difference of sync, freq. sync is considered.
4.	Check Neg Freq Diff.	(0-2.00)Hz	0.10	
5.	Check Phase Ang Diff.	(0-20)°	10	Primary phase difference of Gen and Mains, if it is below phase angle difference of sync, phase sync is considered.
6.	Sync Failure Act	(0-5)	1	0: None; 1: Warning; 2: Block; 3: Trip; 4: Trip and Stop; 5: Shutdown
7.	Sync Failure Delay	(0-3600)s	120	Maximum waiting sync time; if time is due, but it still doesn't meet sync condition, then alarm is issued.
8.	C/O Check Time	(0.1-1.0)s	0.6	At sync transferring, sync close or open output delay starts; during the delay if correct close/open status is detected, then close/open pulse output is stopped; if after the delay correct status still is not detected, then alarm is issued. <b>NOTE:</b> If sync close/open detection time is smaller than close/open time, then sync close/open time is switch close/open time.
9.	Sync Failure Transfer	(0-1)	0	0: Disable 1: Enable
<b>NEL Settings</b>				
1.	Number	(1-3)	3	Details of function description please see the following description.
2.	Auto Trip	(0-1)	0	

No.	Items	Parameters	Defaults	Description	
3.	Auto Trip 1 Set Value	(0-200)%	90		
4.	Auto Trip 1 Delay	(0-3600)s	5		
5.	Auto Trip 2 Set Value	(0-200)%	100		
6.	Auto Trip 2 Delay	(0-3600)s	1		
7.	Auto Reconnection	(0-1)	0		
8.	Auto Reconnection Set Value	(0-200)%	50		
9.	Auto Reconnection Delay	(0-3600)s	5		
<b>Dummy Load</b>					
1.	Number	(1-3)	3		Details of function description please see the following description.
2.	Connect Enable	(0-1)	0		
3.	Connect Set Value 1	(0-200)%	20		
4.	Connect Delay 1	(0-3600)s	5		
5.	Connect Set Value 2	(0-200)%	10		
6.	Connect Delay 2	(0-3600)s	1		
7.	Auto Trip	(0-1)	0		
8.	Trip Set Value	(0-200)%	50		
9.	Trip Delay	(0-3600)s	5		
<b>Expansion Module</b>					
1.	Exp DIN16	(0-1)	0	0: Disable; 1: Enable	
2.	Exp DOUT16	(0-1)	0	0: Disable; 1: Enable	
3.	Exp AIN24 1	(0-1)	0	0: Disable; 1: Enable	
4.	Exp AIN24 2	(0-1)	0	0: Disable; 1: Enable	
5.	Exp AIN16-M02 1	(0-1)	0	0: Disable; 1: Enable	
6.	Exp AIN16-M02 2	(0-1)	0	0: Disable; 1: Enable	
7.	Exp AIN8	(0-1)	0	0: Disable; 1: Enable	
8.	SGE02-4G	(0-1)	0	0: Disable; 1: Enable	
9.	BAC150CAN	(0-1)	0	0: Disable; 1: Enable	

8.2 ENABLE DEFINITION OF DIGITAL OUTPUT PORTS 1-10

8.2.1 DEFINITION OF DIGITAL OUTPUT PORTS 1-10

Table 14 Definition of Digital Output Ports 1-10

No.	Type	Description
0	Not Used	
1	Custom Period 1	Details of function description please see the following description.
2	Custom Period 2	
3	Custom Period 3	
4	Custom Period 4	
5	Custom Period 5	
6	Custom Period 6	
7	Custom Combined 1	
8	Custom Combined 2	
9	Custom Combined 3	
10	Custom Combined 4	
11	Custom Combined 5	
12	Custom Combined 6	
13	Reserved	
14	Reserved	
15	Gas Choke On	When the gas timer is enabled, generator in crank status, it outputs in set choke on time, not output at other status.
16	Gas Ignition Control	When the gas timer is enabled, the action on generator start. After entering ETS status, it doesn't output in ignition off time.
17	Air Flap Control	Act on over speed shutdown and emergency stop. Air inflow can be closed.
18	Audible Alarm	Act on warning, block, trip, trip and stop, and shutdown. An annunciator can be connected externally. If "alarm mute" configurable input port is active, this is prohibited.
19	Louver Control	Act when genset is starting and disconnect when genset is stopped completely.
20	Fuel Pump Control	It is controlled by limit values of level sensor fuel pump.
21	Heater Control	It is controlled by heating limit values of temperature sensor.
22	Cooler Control	It is controlled by cooling limit values of temperature sensor.
23	Fuel Pre-supply	Act in the period from "cranking" to "safety on".
24	Generator Excite	Output in start process. If there is not generator frequency during high-speed running, it shall output for 2 seconds again.
25	Pre-lubricate	Act from pre-heating to safety on.
26	Remote Control	This port is controlled by communication (PC).
27	Reserved	
28	Open Breaker	Control breaker offload when sync. transfer is not enabled.
29	Close Gen Output	It can control generating switch to take load.

No.	Type	Description
30	Open Gen Breaker	It can control generating switch to take off load when sync. transfer is enabled.
31	Close Mains Output	It can control mains switch to take load.
32	Open Mains Breaker	It can control mains switch to take off load when sync. transfer is enabled.
33	Crank Relay	Genset outputs at crank status, not output at other status.
34	Fuel Relay	Act when genset is starting and disconnect when stop is completed. When gas timer is enabled, fuel relay output is used to control gas valve.
35	Idle Control	It is used for unit with idling control. Close before starting and open in warming up delay; Close during stopping idle mode and open when stop is completed.
36	Speed Raise Relay	Act during warming up time.
37	Speed Drop Relay	Act between the period "stop idle" and "failed to stop".
38	Energize to Stop	It is used for engines with ETS electromagnet. Close when stop idle is over and open when pre-set "ETS delay" is over.
39	Speed Drop Pulse	Act for 0.1s when controller enters "stop idle", used for control parts of ECU dropping to idle speed.
40	ECU Stop	Used for ECU engine to control its stop.
41	ECU Power	Used for ECU engine to control its power.
42	Speed Raise Pulse	Act for 0.1s when controller enters warming up delay; used for control parts of ECU raising to normal speed.
43	Crank Success	Close when a successful start signal is detected.
44	Generator OK	Act when generator is normally running.
45	Generator Available	Act between normal running and high-speed cooling.
46	Mains OK	Act when mains is normal.
47	Reserved	
48	Common Alarm	Act when genset common warning, common shutdown, common trip, common trip and stop, common block alarms occur.
49	Common Trip and Stop	Act when common trip and stop alarm occurs.
50	Common Shutdown	Act when common shutdown alarm occurs.
51	Common Trip	Act when common trip alarm occurs.
52	Common Warning	Act when common warning alarm occurs.
53	Common Block	Act when common block alarm occurs.
54	Battery Over Voltage	Act when battery's over voltage warning alarm occurs.
55	Battery Under Voltage	Act when battery's low voltage warning alarm occurs.
56	Charge Alternator Failure	Act when charging failure warning alarm occurs.
57	Reserved	
58	Reserved	
59	Reserved	
60	ECU Warning	Indicates ECU sends a warning signal.

No.	Type	Description
61	ECU Shutdown	Indicates ECU sends a shutdown signal.
62	ECU Comm. Failure	Indicates controller can't communicate with ECU.
63	Reserved	
64	Reserved	
65	Reserved	
66	Reserved	
67	Reserved	
68	Reserved	
69	Input 1 Active	Act when input port 1 is active.
70	Input 2 Active	Act when input port 2 is active.
71	Input 3 Active	Act when input port 3 is active.
72	Input 4 Active	Act when input port 4 is active.
73	Input 5 Active	Act when input port 5 is active.
74	Input 6 Active	Act when input port 6 is active.
75	Input 7 Active	Act when input port 7 is active.
76	Input 8 Active	Act when input port 8 is active.
77	Input 9 Active	Act when input port 9 is active.
78	Input 10 Active	Act when input port 10 is active.
79	Reserved	
80	Reserved	
81	Exp DI Input 1 Active	Act when expansion module DIN16 input port 1 function is active.
82	Exp DI Input 2 Active	Act when expansion module DIN16 input port 2 function is active.
83	Exp DI Input 3 Active	Act when expansion module DIN16 input port 3 function is active.
84	Exp DI Input 4 Active	Act when expansion module DIN16 input port 4 function is active.
85	Exp DI Input 5 Active	Act when expansion module DIN16 input port 5 function is active.
86	Exp DI Input 6 Active	Act when expansion module DIN16 input port 6 function is active.
87	Exp DI Input 7 Active	Act when expansion module DIN16 input port 7 function is active.
88	Exp DI Input 8 Active	Act when expansion module DIN16 input port 8 function is active.
89	Exp DI Input 9 Active	Act when expansion module DIN16 input port 9 function is active.
90	Exp DI Input 10 Active	Act when expansion module DIN16 input port 10 function is active.
91	Exp DI Input 11 Active	Act when expansion module DIN16 input port 11 function is active.
92	Exp DI Input 12 Active	Act when expansion module DIN16 input port 12 function is active.
93	Exp DI Input 13 Active	Act when expansion module DIN16 input port 13 function is active.
94	Exp DI Input 14 Active	Act when expansion module DIN16 input port 14 function is active.
95	Exp DI Input 15 Active	Act when expansion module DIN16 input port 15 function is active.
96	Exp DI Input 16 Active	Act when expansion module DIN16 input port 16 function is

No.	Type	Description
		active.
97	Reserved	
98	Reserved	
99	Emergency Stop	Act when emergency stop alarm occurs.
100	Fail to Start	Act when start failure alarm occurs.
101	Fail to Stop	Act when stop failure alarm occurs.
102	Under Speed Warn	Act when under speed warning occurs.
103	Under Speed Alarm	Act when under speed alarm (except warning) occurs.
104	Over Speed Warn	Act when over speed warning occurs.
105	Over Speed Alarm	Act when over speed alarm (except warning) occurs.
106	Reserved	
107	Reserved	
108	Reserved	
109	Gen Over Freq. Warn	Act when generator over frequency warning occurs.
110	Gen Over Freq. Alarm	Act when generator over frequency alarm (except warning) occurs.
111	Gen Over Volt Warn	Act when generator over voltage warning occurs.
112	Gen Over Volt Alarm	Act when generator over voltage alarm (except warning) occurs.
113	Gen Under Freq. Warn	Act when generator low frequency warning occurs.
114	Gen Under Freq. Alarm	Act when generator low frequency alarm (except warning) occurs.
115	Gen Under Volt. Warn	Act when generator low voltage warning occurs.
116	Gen Under Volt. Alarm	Act when generator low voltage alarm (except warning) occurs.
117	Gen Loss of Phase	Act when generator loss of phase occurs.
118	Gen Reverse Phase Sequence	Act when generator reverse phase sequence occurs.
119	Over Power Warn	Act when gen over power warning occurs.
120	Over Power Alarm	Act (except warning) when over power warning occurs.
121	Reverse Power Warn	Act when gen reverse power warning occurs.
122	Reverse Power Alarm	Act (except warning) when controller detects generator reverse power.
123	Over Current Warn	Act when over current warning occurs.
124	Over Current Alarm	Act when gen over current alarm (except warning) occurs.
125	Mains Inactive	Output when mains is inactive.
126	Mains Over Freq	
127	Mains Over Volt	
128	Mains Under Freq	
129	Mains Under Volt	
130	Mains Phase Seq Wrong	
131	Mains Loss of Phase	
132	Reserved	
133	Reserved	
134	NEL1 Trip	Details of function description please see the following

No.	Type	Description
135	NEL2 Trip	description.
136	NEL3 Trip	
137	Reserved	
138	Reserved	
139	High Temp Warn	Act when high-temperature warning occurs.
140	Low Temp Warn	Act when low temperature warning occurs.
141	High Temp Alarm	Act when high-temperature alarm (except warning) occurs.
142	Reserved	
143	Low OP Warn	Act when low oil pressure warning occurs.
144	Low OP Alarm	Act when low oil pressure alarm (except warning) occurs.
145	OP Sensor Open	Act when oil pressure sensor is open circuit.
146	Reserved	
147	Low FL Warn	Act when controller has low fuel level warning alarm.
148	Low FL Alarm	Act when controller has low fuel level alarm (except warning).
149	Reserved	
150	Flex Sensor 1 High Warn	Act when controller has flexible sensor 1 high warning alarm.
151	Flex Sensor 1 Low Warn	Act when controller has flexible sensor 1 low warning alarm.
152	Flex Sensor 1 High Alarm	Act when controller has flexible sensor 1 high alarm (except warning).
153	Flex Sensor 1 Low Alarm	Act when controller has flexible sensor 1 low alarm (except warning).
154	Flex Sensor 2 High Warn	Act when controller has flexible sensor 2 high warning alarm.
155	Flex Sensor 2 Low Warn	Act when controller has flexible sensor 2 low warning alarm.
156	Flex Sensor 2 High Alarm	Act when controller has flexible sensor 2 high alarm (except warning).
157	Flex Sensor 2 Low Alarm	Act when controller has flexible sensor 2 low alarm (except warning).
158	Flex Sensor 3 High Warn	Act when controller has flexible sensor 3 high warning alarm.
159	Flex Sensor 3 Low Warn	Act when controller has flexible sensor 3 low warning alarm.
160	Flex Sensor 3 High Alarm	Act when controller has flexible sensor 3 high alarm (except warning).
161	Flex Sensor 3 Low Alarm	Act when controller has flexible sensor 3 low alarm (except warning).
162	Exp1 Ch15 High Alarm	Act when expansion AIN24 1 sensor 15 high alarm (except warning) occurs.
163	Exp1 Ch15 High Warn	Act when expansion AIN24 1 sensor 15 high warning occurs.
164	Exp1 Ch15 Low Alarm	Act when expansion AIN24 1 sensor 15 low alarm (except warning) occurs.
165	Exp1 Ch15 Low Warn	Act when expansion AIN24 1 sensor 15 low warning occurs.
166	Exp1 Ch16 High Alarm	Act when expansion AIN24 1 sensor 16 high alarm (except warning) occurs.
167	Exp1 Ch16 High Warn	Act when expansion AIN24 1 sensor 16 high warning occurs.

No.	Type	Description
168	Exp1 Ch16 Low Alarm	Act when expansion AIN24 1 sensor 16 low alarm (except warning) occurs.
169	Exp1 Ch16 Low Warn	Act when expansion AIN24 1 sensor 16 low warning occurs.
170	Exp1 Ch17 High Alarm	Act when expansion AIN24 1 sensor 17 high alarm (except warning) occurs.
171	Exp1 Ch17 High Warn	Act when expansion AIN24 1 sensor 17 high warning occurs.
172	Exp1 Ch17 Low Alarm	Act when expansion AIN24 1 sensor 17 low alarm (except warning) occurs.
173	Exp1 Ch17 Low Warn	Act when expansion AIN24 1 sensor 17 low warning occurs.
174	Exp1 Ch18 High Alarm	Act when expansion AIN24 1 sensor 18 high alarm (except warning) occurs.
175	Exp1 Ch18 High Warn	Act when expansion AIN24 1 sensor 18 high warning occurs.
176	Exp1 Ch18 Low Alarm	Act when expansion AIN24 1 sensor 18 low alarm (except warning) occurs.
177	Exp1 Ch18 Low Warn	Act when expansion AIN24 1 sensor 18 low warning occurs.
178	Exp1 Ch19 High Alarm	Act when expansion AIN24 1 sensor 19 high alarm (except warning) occurs.
179	Exp1 Ch19 High Warn	Act when expansion AIN24 1 sensor 19 high warning occurs.
180	Exp1 Ch19 Low Alarm	Act when expansion AIN24 1 sensor 19 low alarm (except warning) occurs.
181	Exp1 Ch19 Low Warn	Act when expansion AIN24 1 sensor 19 low warning occurs.
182	Exp1 Ch20 High Alarm	Act when expansion AIN24 1 sensor 20 high alarm (except warning) occurs.
183	Exp1 Ch20 High Warn	Act when expansion AIN24 1 sensor 20 high warning occurs.
184	Exp1 Ch20 Low Alarm	Act when expansion AIN24 1 sensor 20 low alarm (except warning) occurs.
185	Exp1 Ch20 Low Warn	Act when expansion AIN24 1 sensor 20 low warning occurs.
186	Exp1 Ch21 High Alarm	Act when expansion AIN24 1 sensor 21 high alarm (except warning) occurs.
187	Exp1 Ch21 High Warn	Act when expansion AIN24 1 sensor 21 high warning occurs.
188	Exp1 Ch21 Low Alarm	Act when expansion AIN24 1 sensor 21 low alarm (except warning) occurs.
189	Exp1 Ch21 Low Warn	Act when expansion AIN24 1 sensor 21 low warning occurs.
190	Exp1 Ch22 High Alarm	Act when expansion AIN24 1 sensor 22 high alarm (except warning) occurs.
191	Exp1 Ch22 High Warn	Act when expansion AIN24 1 sensor 22 high warning occurs.
192	Exp1 Ch22 Low Alarm	Act when expansion AIN24 1 sensor 22 low alarm (except warning) occurs.
193	Exp1 Ch22 Low Warn	Act when expansion AIN24 1 sensor 22 low warning occurs.
194	Exp1 Ch23 High Alarm	Act when expansion AIN24 1 sensor 23 high alarm (except warning) occurs.
195	Exp1 Ch23 High Warn	Act when expansion AIN24 1 sensor 23 high warning occurs.

No.	Type	Description
196	Exp1 Ch23 Low Alarm	Act when expansion AIN24 1 sensor 23 low alarm (except warning) occurs.
197	Exp1 Ch23 Low Warn	Act when expansion AIN24 1 sensor 23 low warning occurs.
198	Exp1 Ch24 High Alarm	Act when expansion AIN24 1 sensor 24 high alarm (except warning) occurs.
199	Exp1 Ch24 High Warn	Act when expansion AIN24 1 sensor 24 high warning occurs.
200	Exp1 Ch24 Low Alarm	Act when expansion AIN24 1 sensor 24 low alarm (except warning) occurs.
201	Exp1 Ch24 Low Warn	Act when expansion AIN24 1 sensor 24 low warning occurs.
202	M02-1 Ch1 Low Warn	Act when expansion AIN16M02 Sensor 1 low warning occurs.
203	M02-1 Ch1 Low Alarm	Act when expansion AIN16M02 Sensor 1 low alarm (except warning) occurs.
204	M02-1 Ch1 High Warn	Act when expansion AIN16M02 Sensor 1 high warning occurs.
205	M02-1 Ch1 High Alarm	Act when expansion AIN16M02 Sensor 1 high alarm (except warning) occurs.
206	M02-1 Ch 2 Low Warn	Act when expansion AIN16M02 Sensor 2 low warning occurs.
207	M02-1 Ch 2 Low Alarm	Act when expansion AIN16M02 Sensor 2 low alarm (except warning) occurs.
208	M02-1 Ch 2 High Warn	Act when expansion AIN16M02 Sensor 2 high warning occurs.
209	M02-1 Ch 2 High Alarm	Act when expansion AIN16M02 Sensor 2 high alarm (except warning) occurs.
210	M02-1 Ch 3 Low Warn	Act when expansion AIN16M02 Sensor 3 low warning occurs.
211	M02-1 Ch 3 Low Alarm	Act when expansion AIN16M02 Sensor 3 low alarm (except warning) occurs.
212	M02-1 Ch 3 High Warn	Act when expansion AIN16M02 Sensor 3 high warning occurs.
213	M02-1 Ch 3 High Alarm	Act when expansion AIN16M02 Sensor 3 high alarm (except warning) occurs.
214	M02-1 Ch 4 Low Warn	Act when expansion AIN16M02 Sensor 4 low warning occurs.
215	M02-1 Ch 4 Low Alarm	Act when expansion AIN16M02 Sensor 4 low alarm (except warning) occurs.
216	M02-1 Ch 4 High Warn	Act when expansion AIN16M02 Sensor 4 high warning occurs.
217	M02-1 Ch 4 High Alarm	Act when expansion AIN16M02 Sensor 4 high alarm (except warning) occurs.
218	Reserved	
219	Reserved	
220	DL1 Connect	Details of function description please see the following description.
221	DL2 Connect	
222	DL3 Connect	
223-229	Reserved	
230	Stop Mode	Act when the system is in Stop mode.
231	Manual Mode	Act when the system is in Manual mode.
232	Reserved	Reserved

No.	Type	Description
233	Auto Mode	Act when the system is in Auto mode.
234	Gen Load Indication	Act when generator takes load.
235	Mains Load Indication	Act when mains takes load.
236	Reserved	
237	Reserved	
238	Reserved	
239	Reserved	
240-279	PLC Flag 1~40	PLC flag output.
280	AIN8 Ch1 Low Warn	Act when expansion AIN8 Sensor 1 low warning occurs.
281	AIN8 Ch1 Low Alarm	Act when expansion AIN8 Sensor 1 low alarm (except warning) occurs.
282	AIN8 Ch1 High Warn	Act when expansion AIN8 Sensor 1 high warning occurs.
283	AIN8 Ch1 High Alarm	Act when expansion AIN8 Sensor 1 high alarm (except warning) occurs.
284	AIN8 Ch 2 Low Warn	Act when expansion AIN8 Sensor 2 low warning occurs.
285	AIN8 Ch 2 Low Alarm	Act when expansion AIN8 Sensor 2 low alarm (except warning) occurs.
286	AIN8 Ch 2 High Warn	Act when expansion AIN8 Sensor 2 high warning occurs.
287	AIN8 Ch 2 High Alarm	Act when expansion AIN8 Sensor 2 high alarm (except warning) occurs.
288	AIN8 Ch 3 Low Warn	Act when expansion AIN8 Sensor 3 low warning occurs.
289	AIN8 Ch 3 Low Alarm	Act when expansion AIN8 Sensor 3 low alarm (except warning) occurs.
290	AIN8 Ch 3 High Warn	Act when expansion AIN8 Sensor 3 high warning occurs.
291	AIN8 Ch 3 High Alarm	Act when expansion AIN8 Sensor 3 high alarm (except warning) occurs.
292	AIN8 Ch 4 Low Warn	Act when expansion AIN8 Sensor 4 low warning occurs.
293	AIN8 Ch 4 Low Alarm	Act when expansion AIN8 Sensor 4 low alarm (except warning) occurs.
294	AIN8 Ch 4 High Warn	Act when expansion AIN8 Sensor 4 high warning occurs.
295	AIN8 Ch 4 High Alarm	Act when expansion AIN8 Sensor 4 high alarm (except warning) occurs.
296-299	Reserved	

### 8.2.2 DEFINED PERIOD OUTPUT

Defined period output is composed by 2 parts, **period output S1** and **condition output S2**.



While **S1** and **S2** are **TRUE** synchronously, **OUTPUT**;

While **S1** or **S2** is **FALSE**, **NOT OUTPUT**.

**Period output S1** can set generator's one or more period outputs freely, can set the delayed time and output time after entering into period.

**Condition output S2** can set as any conditions in output ports.

**▲NOTE 1:** When delay time and output time both are 0 in period output S1, it is TRUE in this period.

**▲NOTE 1:** When selected period is standby, it is cycle output, and other periods are single output.

For example:

Output period: start

Delay output time: 2s

Output time: 3s

Condition output contents: input port 1 is active

Close when condition output active/inactive: close when active (disconnect when inactive);

Output port 1 active, after enter "starts time" and delay 2s, this defined period output is outputting, after 3s, stop outputting;

Output port 1 inactive, defined output period is not outputting.

### 8.2.3 DEFINED COMBINATION OUTPUT

Defined combination output is composed by 3 parts, **or condition output S1**, **or condition output S2**, and **condition output S3**.

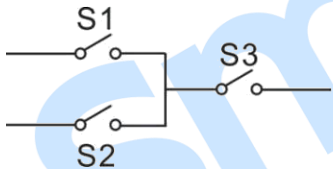

**S1** or **S2** is **TRUE**, while **S3** is **TRUE**, defined combination output is outputting;

**S1** and **S2** are **FALSE**, or **S3** is **FALSE**, defined combination output is not outputting.

**▲NOTE:** S1, S2, S3 can be set as any contents except for "defined combination output" itself in the output setting.

**▲NOTE:** 3 parts of defined combination output (S1, S2, S3) couldn't include or recursively include themselves.

For example:

Contents of or condition output S1: input port 1 is active;

Close when or condition output S1 is active /inactive: close when active (disconnect when inactive);

Contents of or condition output S2, input port 2 is active;

Close when or condition output S2 is active /inactive: close when active (disconnect when inactive);

Contents of and condition output S3: input port 3 is active;

Close when and condition output S3 is active /inactive: close when active (disconnect when inactive);

When input port 1 active or input port 2 active, if input port 3 is active, defined combination output is outputting; If input port 3 inactive, defined combination output is not outputting;

When input port 1 inactive and input port 2 inactive, whatever input port 3 is active or not, defined combination output is not outputting.

8.3 DEFINED CONTENTS OF DIGITAL INPUT PORTS 1-10

Table 15 Definition of Digital Input Ports 1-10 (GND Connected (B-) is active)

No.	Type	Description
0	User-defined	Users-defined alarm. Active range: Never: input inactive. Always: input is active all the time. From crank: detecting as soon as start. From safety on: detecting after safety on run delay. Active type: Close to activate; Open to activate. Delay: range (0-20.0s), default 2.0s.
1	Reserved	
2	Alarm Mute	Can prohibit "Audible Alarm" output when input is active.
3	Reset Alarm	Can reset shutdown, trip and stop, trip, block and warning alarm when input is active.
4	60Hz Active	Use for CANBUS engine and it is 60Hz when input is active.
5	Lamp Test	All LED indicators are illuminated when input is active.
6	Panel Lock	All keys on panel is inactive except navigation key and there is  in the right top corner in LCD when input is active.
7	Preheat	When genset enters preheat status, if input is active, it will always keep preheat status.
8	Idle Control Mode	Under voltage/frequency/speed protection is inactive.
9	Auto Stop Inhibit	In <b>Auto</b> mode, during generator normal running, when input is active, prohibit generator shutdown automatically.
10	Auto Start Inhibit	In <b>Auto</b> mode, prohibit generator start automatically when input is active.
11	Scheduled Start Inhibit	In <b>Auto</b> mode, prohibit scheduled start genset when input is active.
12	Reserved	
13	Gen Closed Aux	Connect generator loading switch's auxiliary point.
14	Gen Load Inhibit	Prohibit genset switch on when input is active.
15	Mains Closed Aux	Connect mains loading switch's auxiliary point.
16	Mains Load Inhibit	Prohibit mains switch on when input is active.
17	Auto Mode Input	When input is active, controller enters into Auto mode.
18	Auto Mode Inhibit	When input is active, controller won't work under Auto mode. Auto key on the panel and simulate auto key input do not work.
19	Controller Backlit	When input is active, LCD backlit is under half lit.
20	Controller Buzzer	When input is active, buzzer constantly outputs.
21	Alarm Stop Inhibit	All shutdown alarms are prohibited except emergency stop. (Means battle mode or override mode)
22	Instrument Mode	All outputs are prohibited in this mode.

No.	Type	Description
23	Reset Maintenance 1	Controller will set maintenance time and date as default when input is active.
24	Reset Maintenance 2	
25	Reset Maintenance 3	
26	High Temp. Shutdown	Connected sensor digital input.
27	Low OP Shutdown	Connected sensor digital input.
28	Remote Start Onload	In <b>Auto</b> mode, when input is active, genset can start automatically and take load after genset is OK; when input inactive, genset will stop automatically.
29	Remote Start Offload	In <b>Auto</b> mode, when input is active, genset can start automatically and won't take load after genset is OK; when input is inactive, genset will stop automatically.
30	Manual Start Aux	In <b>Manual</b> mode, when input is active, genset will start automatically; when input is inactive, genset will stop automatically. An external button can be connected to simulate as pressed.
31	Reserved	
32	Reserved	
33	Simulate Stop Key	An external button can be connected to simulate as pressed.
34	Simulate Manual Key	
35	Reserved	
36	Simulate Auto Key	An external button can be connected to simulate as pressed.
37	Simulate Start Key	
38	Simulate Gen C/O Key	
39	Simulate Mains C/O Key	
40	Low Water Level	Connect digital input of water level sensor.
41	Detonation Shutdown	Connect alarm input of detection module.
42	Middle Speed	
43	Rated Speed	
44	First Priority	
45	Aux Mains OK	In Auto mode, when input is active, it means Mains is normal.
46	Aux Mains Failure	In Auto mode, when input is active, it means Mains is abnormal; When input is active, alternative configuration is active; Alt. configuration can be set to different parameters for the convenience of users to select current configuration by input selection.
47	Alternative Config 1	When input is active, alt. configuration is active; Users can set different parameters to make it easy to select current configuration via input port.
48	Alternative Config 2	
49	Alternative Config 3	
50	Gas Leak Shutdown	Connect alarm input of detection module.
51	NEL Manual Trip	An external button (Not self-locking) can be connected; For function details please refer to following description.
52	NEL Manual Reconnect	
53	DL Manual Connect	An external button (Not self-locking) can be connected; For function details please refer to following description.
54	DL Manual Disconnect	
55	AIN16M02-1 mA-1	When AIN16M02-1 is enabled, input is active, 4-20mA output 1

No.	Type	Description
	Output	outputs current according to the set parameters automatically. When input is inactive, it outputs set default value (SW1).
56	AIN16M02-1 mA-2 Output	When AIN16M02-1 is enabled, input is active, 4-20mA output 2 outputs current according to the set parameters automatically. When input is inactive, it outputs set default value (SW1).
57	AIN16M02-1 mA-3 Output	When AIN16M02-1 is enabled, input is active, 4-20mA output 3 outputs current according to the set parameters automatically. When input is inactive, it outputs set default value (SW1).
58	AIN16M02-2 mA-1 Output	When AIN16M02-2 is enabled, input is active, 4-20mA output 1 outputs current according to the set parameters automatically. When input is inactive, it outputs set default value (SW1).
59	AIN16M02-2 mA-2 Output	When AIN16M02-2 is enabled, input is active, 4-20mA output 2 outputs current according to the set parameters automatically. When input is inactive, it outputs set default value (SW1).
60	Raise Speed Pulse Input	When engine type is 35 MTSC1 and input is active, target engine speed raises to 50RPM.
61	Drop Speed Pulse Input	When engine type is 35 MTSC1 and input is active, target engine speed reduces to 50RPM.
62	AIN16M02-2 mA-3 Output	When AIN16M02-2 is enabled, input is active, 4-20mA output 3 outputs current according to the set parameters automatically. When input is inactive, it outputs set default value (SW1).
63	Reserved	
64	Reserved	
65	Reserved	
66	Reserved	
67	Reserved	
68	Reserved	
69	Reserved	
70	Reserved	

8.4 SELECTION OF SENSORS

Table 16 Sensor Selection

No.	Sensor	Description	Remark
1	Temperature Sensor	0 Not used 1 Custom Res Curve 2 Custom (4-20)mA curve 3 Custom (0-10)V curve 4 VDO 5 CURTIS 6 DATCON 7 SGX 8 SGD 9 SGH 10 PT100 11 SUSUKI 12 PRO 13-15 Reserved	Defined resistance's range is (0~6)kΩ. Factory default is SGD sensor.
2	Oil Pressure (Pressure) Sensor	0 Not used 1 Custom Res Curve 2 Custom (4-20)mA curve 3 Custom (0-10)V curve 4 VDO 10Bar 5 CURTIS 6 DATCON 10Bar 7 SGX 8 SGD 9 SGH 10 VDO 5Bar 11 DATCON 5Bar 12 DATCON 7Bar 13 SUSUKI 14 PRO 15 Reserved	Default resistance type; Defined resistance's range is (0~6)kΩ. Default is SGD sensor.
3	Level (Fuel Level) Sensor	0 Not used 1 Custom Res Curve 2 Custom (4-20)mA curve 3 Custom (0-10)V curve 4 SGD 5 SGH 6-15 Reserved	Defined resistance's range is (0~6)kΩ. Factory default is SGH sensor.

**NOTE:** The input signal of Pressure, Fuel Level, flexible sensor 1, flexible sensor 2 can be resistance, current and voltage.

## 8.5 CONDITIONS OF CRANK DISCONNECT SELECTION

**Table 17 Crank Disconnect Conditions Selection**

No.	Setting Description
0	Frequency
1	Speed
2	Speed + Frequency
3	Oil pressure
4	Oil pressure + Frequency
5	Oil pressure + Speed
6	Oil pressure + Speed + Frequency

**▲NOTES:**

- 1) There are 3 conditions to make starter disconnected with engine, that is, speed, frequency and engine oil pressure. They all can be used separately. We recommend that engine oil pressure should be used with speed and generator frequency together, in order to make the starter motor separated with engine immediately.
- 2) Speed sensor is the magnetic equipment which is installed in starter for detecting flywheel teeth.
- 3) When it is set as speed sensor, users must ensure that the number of flywheel teeth is the same as setting, otherwise, "over speed stop" or "under speed stop" may be caused.
- 4) If genset without magnetic sensor, please don't select corresponding items, otherwise, "start fail" or "loss speed signal" may be caused.
- 5) If genset without oil pressure sensor, please don't select corresponding items.
- 6) If speed sensor is not selected in crank disconnect setting, the speed displayed on controller is calculated by generating signals.

## 9 PARAMETERS SETTING

Please change the controller parameters when generator is in standby mode only (e. g. Start conditions selection, configurable input, configurable output, various delay etc.), otherwise, alarming to stop and other abnormal conditions may happen.

**▲NOTE:** Maximum set value must over minimum set value in case that the condition of too high as well as too low will happen.

**▲NOTE:** When the warning alarm is set, please set the correct return value; otherwise, maybe there is abnormal alarm. When the maximum value is set, the return value must be less than the set value; when the minimum value is set, the return value must be over the set value.

**▲NOTE:** Please set the generator frequency value as low as possible when the genset is cranking, in order to make the starter separated quickly as soon as crank disconnection happens.

**▲NOTE:** Configurable input could not be set as the same items; otherwise, there are abnormal functions. However, the configurable output can be set as the same items.

## 10 CYCLE START

Cycle start is to control two gensets to start circularly. Two gensets are connected by CAN(2) or RS485(2). Master can control backup to start/stop genset by sending commands and check backup fault status. Master and backup can be set by parameter configurations, or decided by input setting. It is only active in Auto mode.

Operation procedure:

- a) Master waits for start and when remote start input is active, it starts automatically. Running time is the pre-set "Master Running Time";
- b) "Master Running Time" is over or shutdown alarm occurs, master sends start command to backup; and when backup remote start input is active, backup starts; when backup runs normally, master stops; backup running time is the pre-set time;
- c) In the whole process, master and backup can change current status information at real time by CAN(2) and RS485(2); when running time is over or backup shutdown alarm occurs, master starts again and it goes like this circularly;
- d) When communication is interrupted, controller issues "Cycle Communication Failure" alarm; when master remote start input is active, master starts; when backup remote start input is active, backup starts.

11 SENSOR SETTING

- 1) When sensors are reselected, the sensor curves will be transferred into the standard value. For example, if temperature sensor is SGH (120°C resistor type), its sensor curve is SGH (120°C resistor type); if select the SGD (120°C resistor type), the temperature sensor curve is SGD curve.
- 2) When there is difference between standard sensor curves and used sensor curves, users can select custom sensor curve and input self-defined sensor curve.
- 3) When the sensor curve is inputted, X value (resistor) must be inputted from small to large, otherwise, mistake occurs.
- 4) If sensor type is selected as “none”, sensor curve is not working.
- 5) If the corresponding sensor has alarm switch only, users must set this sensor as “none”, otherwise, shutdown or warning may occur.
- 6) The headmost or backmost values in the vertical coordinates can be set as the same as below.

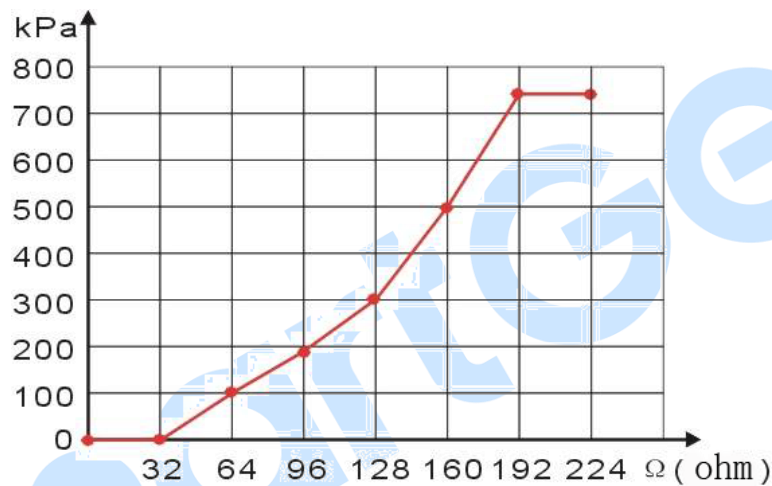

Fig.5 Sensor Curve Diagram

Table 18 Normal Pressure Unit Conversion Form

Item	N/m <sup>2</sup> Pa	kgf/cm <sup>2</sup>	bar	psi
1Pa	1	1.02x10 <sup>-5</sup>	1x10 <sup>-5</sup>	1.45x10 <sup>-4</sup>
1kgf/cm <sup>2</sup>	9.8x10 <sup>4</sup>	1	0.98	14.2
1bar	1x10 <sup>5</sup>	1.02	1	14.5
1psi	6.89x10 <sup>3</sup>	7.03x10 <sup>-2</sup>	6.89x10 <sup>-2</sup>	1

## 12 COMMISSIONING

Please make sure the following checks are made before commissioning,

- Ensure all the wiring connections are correct and wire diameter is suitable.
- Ensure that the controller DC power has fuse, and controller's positive and negative and starter battery are correctly connected.
- Emergency stop input is connected to the positive pole of starter battery via emergency stop button's normally closed point and fuse.
- Take proper actions to prevent engine from cranking successfully (e. g. Remove the connection wire of fuel valve). If checking is OK, make the start battery power on; choose manual mode and controller will executive routine.
- Set controller under manual mode, press "start" button, and genset will start. After the cranking times set before, controller will send signal of Start Failure; then press "stop" to reset controller.
- Recover the action to prevent engine from cranking successfully (e. g. Connect wire of fuel valve), press start button again, and genset will start. If everything goes well, genset will be normally running after idle running (if idle run is set). During this time, please watch engine's running situation and AC generator's voltage and frequency. If there is something abnormal, stop genset and check all wiring connections according to this manual.
- Select the **AUTO** mode from controller's panel, and connect mains signal. After the mains normal delay, controller will transfer ATS (if set) into mains onload. After cooling time, controller will stop genset and make it into "at rest" mode until there is mains abnormal situation.
- When mains is abnormal again, genset will be started automatically and enter into normal running, then controller send signal to make generator switch on, and control the ATS transfer into generator load. If it is not like this, please check ATS wiring connection according to this manual.
- If there is any other question, please contact SmartGen's service.

13 TYPICAL APPLICATION

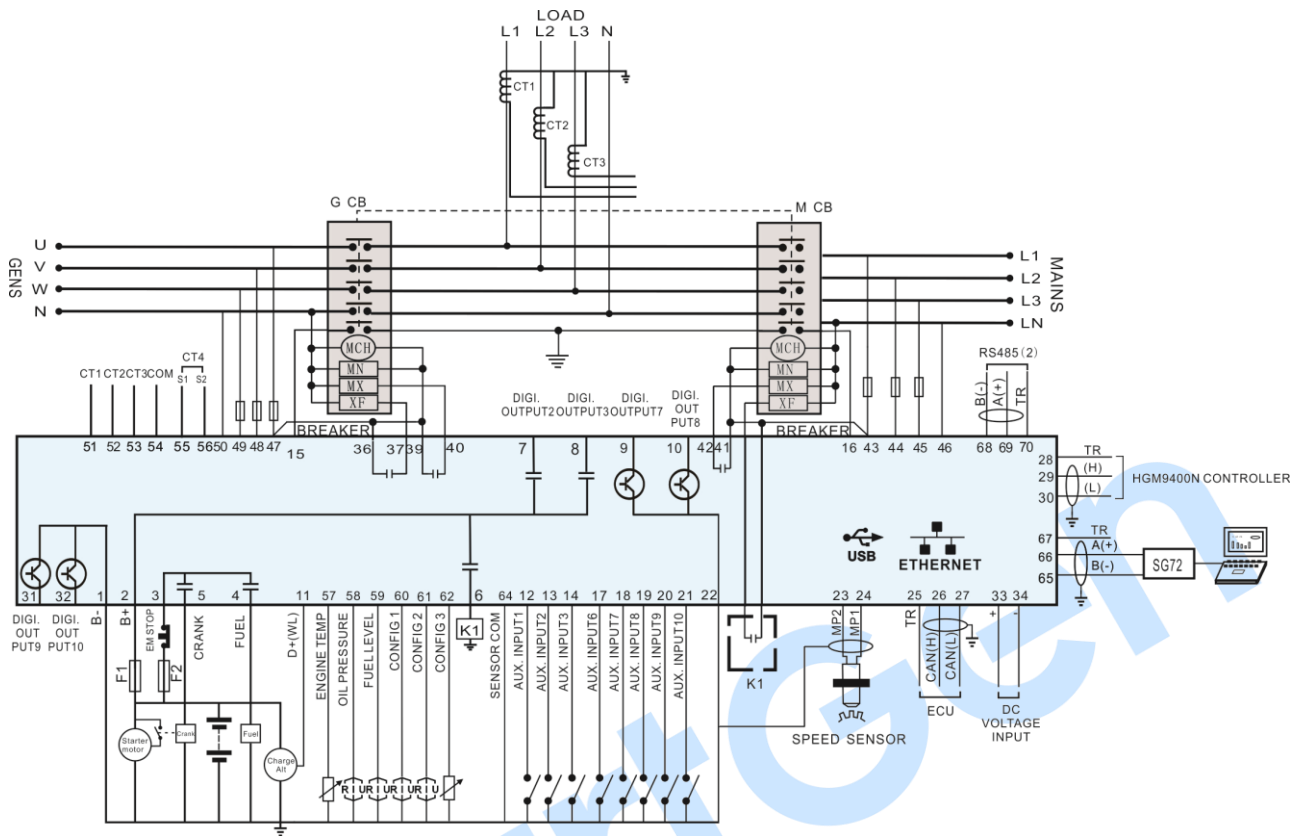

Fig.6 HGM9420N\_HGM9420LT Sync Transfer Typical Application Diagram

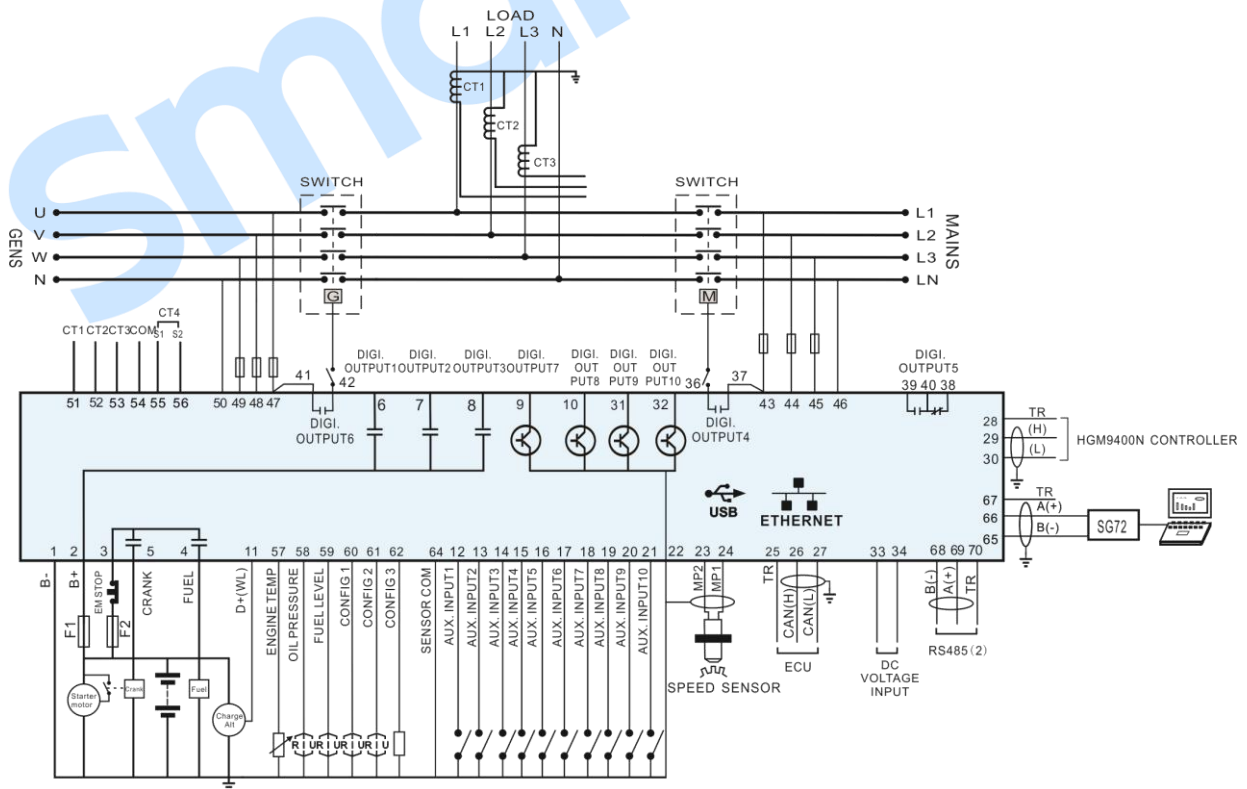
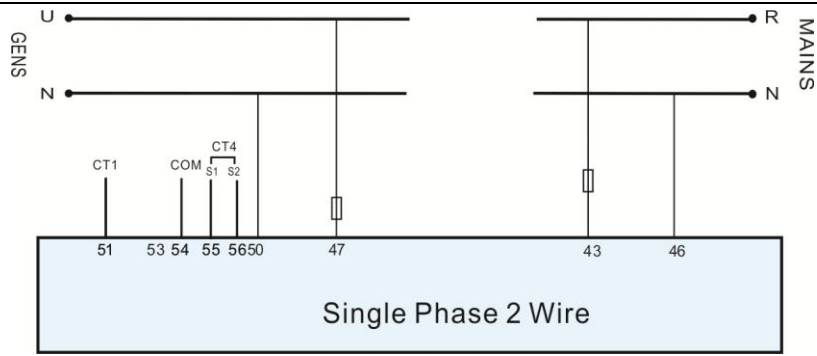
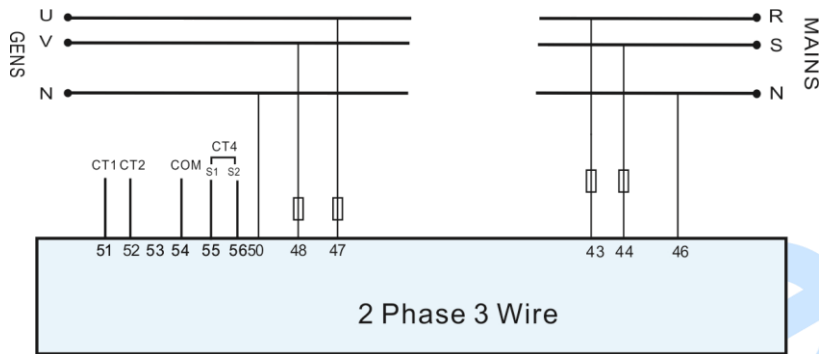

Fig.7 HGM9420N\_HGM9420LT Typical Application Diagram



**Fig.8 Single Phase 2-Wire Wiring Diagram**



**Fig.9 2-Phase 3-Wire Wiring Diagram**

**▲NOTE:** It is recommended to expand large capacity relay for Crank, and Fuel output terminals.

14 NEL TRIP DESCRIPTION

Non-essential Load---NEL is the abbreviation.

The controller can control the NEL1, NEL2 and NEL3 to trip separately. The order of the essentiality is: NEL3 > NEL2 > NEL1

◆ Auto Trip

When NEL auto trip is enabled:

If the genset power has exceeded the NEL trip value, after the trip delay, NEL1 will trip the earliest, and then is NEL2, NEL3.

When NEL auto reconnection is enabled:

If the genset power has fallen below the auto reconnection set value, after the auto reconnection delay, NEL3 will reconnect the earliest, and then is NEL2, NEL1.

t1: NEL Trip Delay  
t2: Reconnection Delay

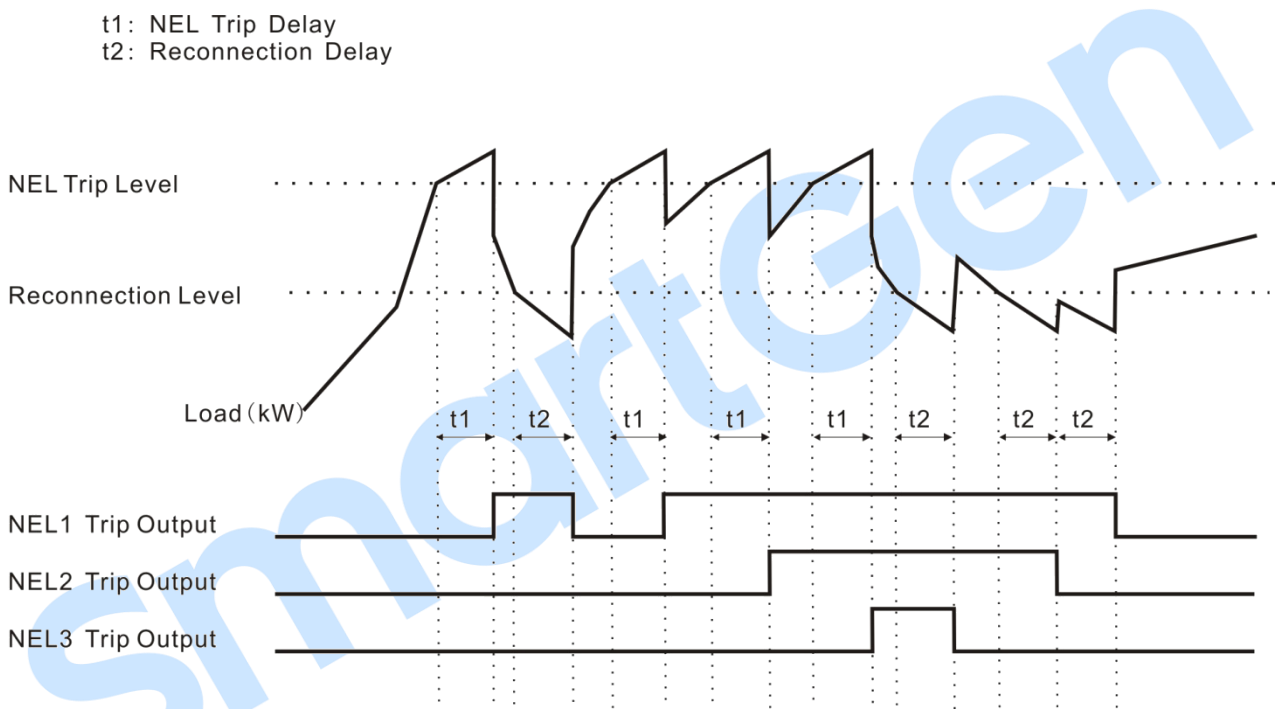

Fig.10 NEL Sequence

◆ Manual Trip

If NEL manual trip input is active (earthed falling edge is active), NEL1 will trip without delay; If NEL manual trip input is active again, NEL2 will trip; If NEL manual trip input is active the third time, NEL3 will trip.

If NEL manual reconnection input is active (earthed falling edge is active), NEL3 will reconnect without delay; If NEL manual reconnection input is active again, NEL2 will reconnect; If NEL manual reconnection input is active for the third time, NEL1 will reconnect. During this process, the genset power judges if the genset power has fallen below the NEL reconnection value. If genset power is less than NEL reconnection value, then the input is active; otherwise the input is deactivated.

▲NOTE: When auto trip and auto reconnection are enabled, manual trip is still active.

15 DUMMY LOAD CONNECTION

Dummy Load --- DL for short.

The controller can control the 3 ways of DL connect separately. The order of the essentiality is: DL1 > DL2 > DL3

◆ Auto operation

When DL auto connect is enabled:

If the genset power has fallen below the DL connection value, after the connection delay, DL1 will connect the earliest, and then is DL2, DL3;

When DL auto disconnect is enabled:

If the genset power has exceed the DL disconnect value, after the disconnect delay, DL3 will disconnect the earliest, and then is DL2, DL1.

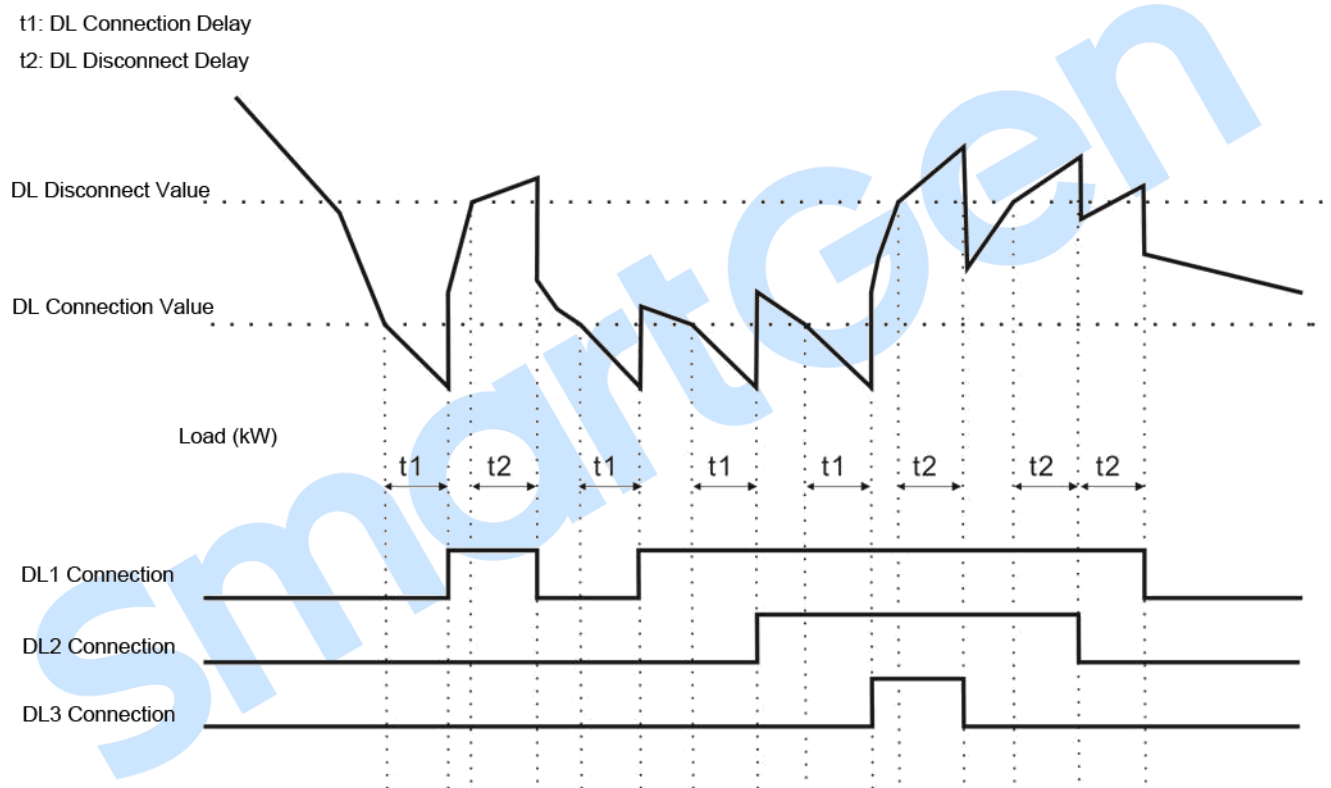

Fig.11 DL Sequence

◆ Manual Operation

If manual DL connect input is active (earthed falling edge is active), DL1 will connect without delay; If manual DL connect input is active again, DL2 will connect; If manual DL connect input is active the third time, DL3 will connect. During this process, the controller will detect if the genset power has fallen the DL connection value or not. If genset power is below DL connection value, this input is active, otherwise, it will be ignored.

If manual DL disconnect input is active (earthed falling edge is active), DL3 will disconnect without delay; If manual DL disconnect input is active again, DL2 will disconnect; If manual DL disconnect input is active the third time, DL1 will disconnect.

▲NOTE: When auto connection and auto disconnection are enabled, manual operation is still active.

16 FUEL CONSUMPTION ILLUSTRATION

Fuel consumption parameters include: fuel tank remaining, real time fuel consumption, fuel remaining time.

Remaining fuel is calculated by fuel level sensor value and the pre-set fuel tank volume.

Real-time fuel consumption is calculated by real-time active power and fuel consumption curve. About fuel consumption curve settings, set genset power and the corresponding fuel consumption volume per hour, set curve X axis (1-8) points to genset power (kW), and set curve Y axis (1-8) points to genset fuel consumption volume per hour. Real-time fuel consumption is as below:

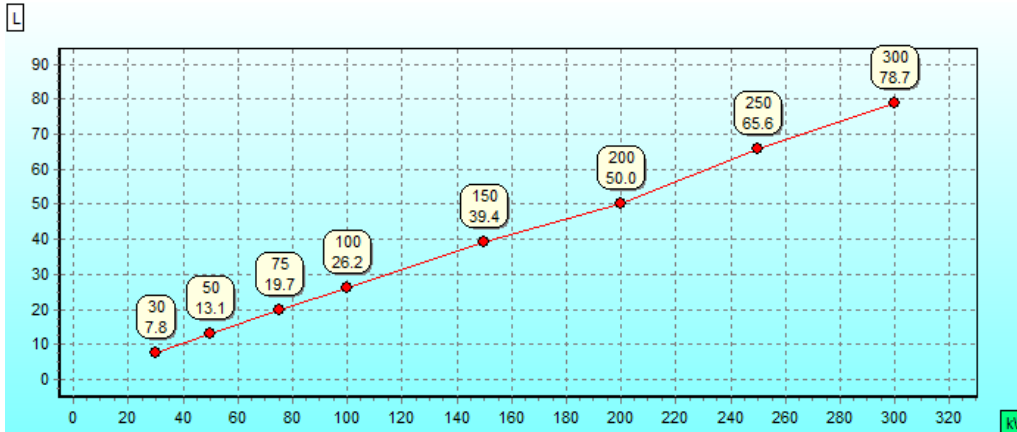

Fig.12 Fuel Consumption Curve

Fuel remaining time is equal to the remaining fuel dividing genset fuel consumption per hour.

**NOTE:** It needs to enable Fuel Level Sensor, Fuel Tank Capacity, Real-time Fuel Consumption Curve.

## 17 ETHERNET PORT

Ethernet port can be used to monitor the controller, which can realize network client terminal connection.

**▲NOTE:** After changing network setting parameters (IP address, subnet mask etc.) of the controller, it needs to power on the controller again, so that new parameter settings can be valid.

As network client, controller can be monitored via network port by TCP/IP Modbus protocol by users.

Steps are as below:

1. Set controller IP address and subnet mask, the set IP address needs to be in the same stage with monitoring device (PC), but they are different. For example: IP address of monitoring device is 192.168.0.16, then IP address of controller needs to set to 192.168.0.18, and subnet mask is 255.255.255.0.
2. Connect controller. Users can directly use network wire to connect monitoring device and controller; interchanger is okay as well.
3. Monitoring device uses TCP Modbus protocol to communicate with controller.

**▲NOTE:** Controller parameters can be set in this connection mode. Test software of our company can connect in this way. Ask for the communication protocol from our company personnel.

## 18 HOST USB PORT

HGM9420N\_HGM9420LT controller supports to insert U flash of FAT32 format. By inserting U flash, it can realize:

- ◆ Lead-in and lead-out function of configured parameters
  1. Check xxx.lgm configuration files in the U flash;
  2. Upload configuration files of HGM9400NXXXX.lgm format to controller;
  3. Save controller configuration parameters to corresponding HGM9400NXXXX.lgm file;
  4. Save new configuration file (HGM9400NXXXX.lgm).
- ◆ Historical data saving

Historical data saving files are named by year and month. For .dat files named by year-month-day, genset saves data per minute at standby status, at other statuses data are saved per second. If the memory room in the U flash is less than or equal to 200MB, then the earliest month memory files will be deleted.

Historical data files are as below:

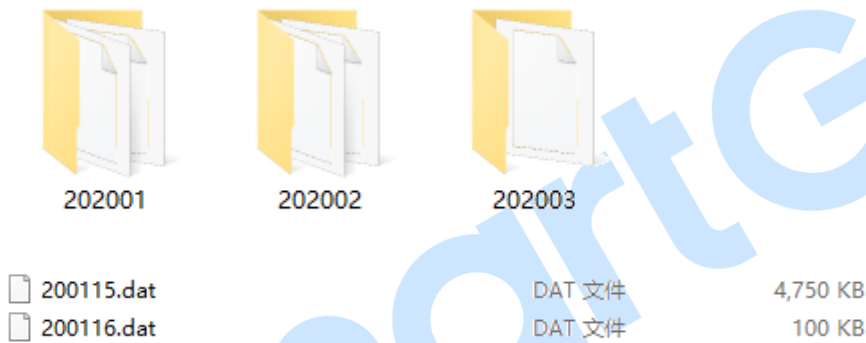

Historical data curves can be checked by the historical data analysis function of data iGMP6 software.

19 INSTALLATION

19.1 SGE02 EXPANSION MODULE

19.1.1 4G ANTENNA PORT

Connect 4G antenna with 4G port of SGE02.  
 Antenna port: 50Ω/SMA connector.

19.1.2 GPS ANTENNA PORT

By using GPS function, connect GPS antenna and GPS port of SGE02.

**NOTE:** GPS antenna needs to be put outdoor, otherwise location information is not correct or users cannot obtain location information.

Antenna port: 50Ω/SMA connector, active antenna.

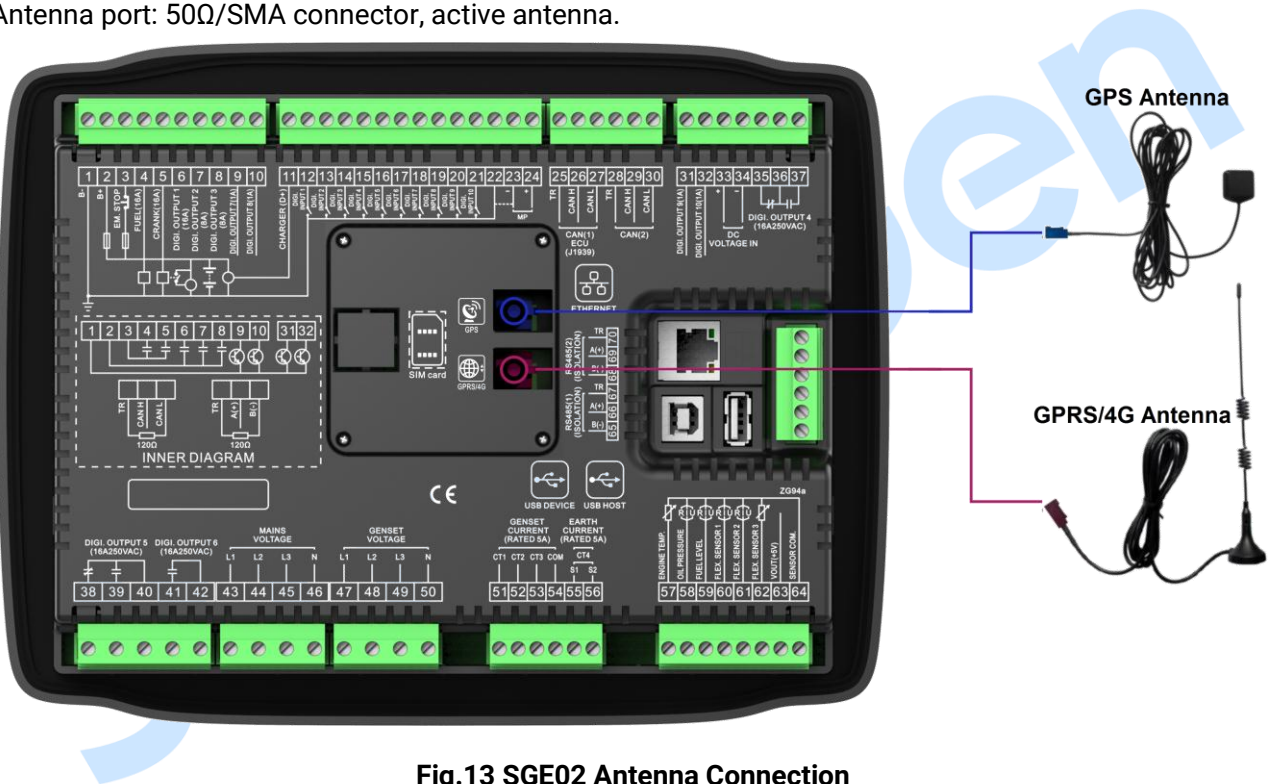



Fig.13 SGE02 Antenna Connection

19.1.3 SIM CARD INSTALLATION

Insert 4G, 3G or 2G SIM card, controller will connect the server by wireless mobile network.

**NOTE:** This module supports Netcom 4G wireless network, applying standard SIM card (dimension 25mmx15mm); if controller displays  mark, it means SIM card is not in, or SIM card is poor contact.

Installation Step is as below.



Fig.14 SIM Card Installation Method

19.2 FIXING CLIPS

- This controller is built-in design and is fixed by clips when installation.
- Withdraw the fixing clip screw (turn anticlockwise) until it reaches proper position.
- Pull the fixing clip backwards (towards the back of the module) ensuring four clips are inside their allotted slots.
- Turn the fixing clip screws clockwise until they are fixed on the panel.
- Care should be taken not to over tighten the screws of fixing clips.

19.3 CASE DIMENSIONS AND CUTOUT SIZE

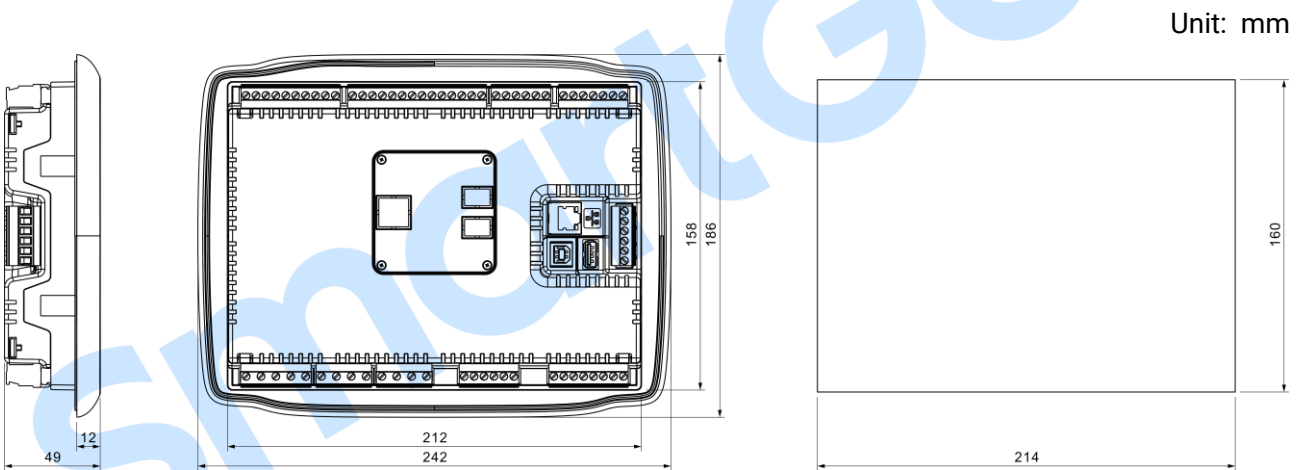

Fig.15 Case Dimension and Cutout Size

HGM9420N\_HGM9420LT controller can suit for (8~35) VDC battery voltage environment. Battery negative electrode must be connected with the starter shell stably. The wire area connecting controller power B+/B- with negative and positive electrodes of battery mustn't be less than 2.5mm<sup>2</sup>. If floating charger is configured, please firstly connect output wires of charger to battery's positive and negative directly, and then connect wires from battery's positive and negative to controller's positive and negative input ports separately in order to prevent the charger from disturbing the controller's normal working.

- **Speed Sensor Input:** Speed sensor is the magnetic equipment installed in the engine body to detect flywheel teeth number. The wires used to connect with the controller shall be 2-core shielding wires. The shielding layer shall be connected to No.22 terminal on the controller, and meanwhile the other terminal shall be hanging in the air. Another two signal wires shall be connected to No.23 and No.24 terminals on the controller. The output voltage of the speed sensor shall be within (1~24) VAC (effective value) in the range of full speed and 12VAC is

recommended (at rated speed). As to speed sensor installation, the sensor can firstly be spun to the connection flywheel, then invert 1/3 lap, and finally tighten up the screw on the sensor.

- **Output and Expand Relays:** All controller outputs are relay contact outputs. If the expansion relay is needed, freewheel diode (relay coil is DC) and resistor and capacitor circuit (relay coil is AC) shall be added to the two ends of the relay coils in order to prevent disturbing the controller or others equipment.
- **Alternate Current Input:** HGM9420N\_HGM9420LT controller current input must be connected to outside current transformer. The secondary side current of the current transformer must be 5A and at the same time current transformer phase and input voltage phase must be correct, otherwise the collected current and active power may not be correct.
- **Withstand Voltage Test:** When controller had been installed in control panel, if high voltage test is needed, please disconnect controller's all terminal connections, in order to prevent high voltage into controller and damage it.

▲**NOTE1:** ICOM port must be connected to negative pole of battery.

▲**NOTE2:** When there is load current, transformer's secondary side is prohibited open circuit.

SmartGen

20 SMS MESSAGE ALARM AND REMOTE CONTROL

20.1 SMS MESSAGE ALARM

When controller detects alarms, it will send message automatically to the pre-set telephone numbers.

**NOTE:** All shutdown alarms, trip and stop alarms, trip alarms can send messages to the pre-set telephone numbers automatically. For warning alarms, controller will send messages to the phone according to user configurations.

20.2 SMS MESSAGE REMOTE CONTROL

Users send message commands to wireless communication module, then controller will execute related actions based on message commands, and return related execution information. Controller only executes the message commands from its own pre-set phone numbers. Detailed message commands are as below.

Table 19 SMS Message Order List

No.	Message Command	Message Return Information	Description
1	SMS GENSET	GENSET ALARM	Genset stop alarm or trip and stop alarm
		SYSTEM IN STOP MODE GENSET AT REST	In stop mode, standby status
		SYSTEM IN MANUAL MODE GENSET AT REST	In manual mode, standby status
		SYSTEM IN AUTO MODE GENSET AT REST	In auto mode, standby status
		SYSTEM IN STOP MODE GENSET IS RUNNING	In stop mode, start status
		SYSTEM IN MANUAL MODE GENSET IS RUNNING	In manual mode, start status
		SYSTEM IN AUTO MODE GENSET IS RUNNING	In auto mode, start status
2	SMS START	GENSET ALARM	Genset stop alarm or trip and stop alarm
		STOP MODE NOT START	In stop mode, cannot start
		SMS START OK	In manual mode, is starting
		AUTO MODE NOT START	In auto mode, cannot start
3	SMS STOP MODE	SMS STOP OK	Set to stop mode
4	SMS MANUAL MODE	SMS MANUAL MODE OK	Set to manual mode
5	SMS AUTO MODE	SMS AUTO MODE OK	Set to auto mode
6	SMS DETAIL	Return information can be set by PC software.	Obtain genset details

**NOTE:** Users shall send commands according to the contents of above table. All letters shall be capital.

**▲NOTE:** SMS DETAIL returned detailed information includes: working mode, Mains voltage, Gen voltage, load current, Mains frequency, Gen frequency, active power, apparent power, power factor, battery voltage, D+ voltage, water temperature, oil pressure, fuel level, speed, accumulated running time, genset status, alarm status.

SmartGen

21 CONNECTIONS OF CONTROLLER AND J1939 ENGINE

21.1 CUMMINS ISB/ISBE

Table 20 Connector B

Terminals of controller	Connector B	Remark
Aux. output 1	39	Configured to "Fuel Relay Output";
Starting relay output	-	Connected with starter coil directly;
Aux. output 2	Expansion 30A relay; providing battery voltage for terminal 01, 07, 12, 13.	Set to "ECU power".

Table 21 9-Pin Connector

Terminals of controller	9 pins connector	Remark
CAN_SCR	SAE J1939 shield	CAN communication shielding line (connected with ECU terminal only);
CAN(H)	SAE J1939 signal	Impedance 120Ω connecting line is recommended;
CAN(L)	SAE J1939 return	Impedance 120Ω connecting line is recommended.

Engine type: Cummins ISB.

21.2 CUMMINS QSL9

Suitable for CM850 engine control module.

Table 22 50-Pin Connector

Terminals of controller	50 pins connector	Remark
Aux. output 1	39	Configured to "Fuel Relay Output";
Starting relay output	-	Connected to starter coil directly.

Table 23 9-Pin Connector

Terminals of controller	9 pins connector	Remark
CAN_SCR	SAE J1939 shield-E	CAN communication shielding line (connected with ECU terminal only);
CAN(H)	SAE J1939 signal-C	Using impedance 120Ω connecting line;
CAN(L)	SAE J1939 return-D	Using impedance 120Ω connecting line.

Engine type: Cummins-CM850.

**21.3 CUMMINS QSM11 (IMPORT)**

It is suitable for CM570 engine control module. Engine type is QSM11 G1, QSM11 G2.

**Table 24 C1 Connector**

Terminals of controller	C1 connector	Remark
Aux. output 1	5&8	Configured to "Fuel Relay Output"; External expansion relay; at fuel output, make port 5 and port 8 of C1 connector connected;
Starting relay output	-	Connected to starter coil directly.

**Table 25 3-Pin Data Link Connector**

Terminals of controller	3 pins data link connector	Remark
CAN_SCR	C	CAN communication shielding line (connected with ECU terminal only);
CAN(H)	A	Using impedance 120Ω connecting line;
CAN(L)	B	Using impedance 120Ω connecting line.

Engine type: Cummins ISB.

**21.4 CUMMINS QSX15-CM570**

It is suitable for CM570 engine control module. Engine type is QSX15 etc.

**Table 26 50-Pin Connector**

Terminals of controller	50 pins connector	Remark
Aux. output 1	38	Injection switch; Configured to "Fuel Relay Output";
Starting relay output	-	Connected to starter coil directly.

**Table 27 9-Pin Connector**

Terminals of controller	9 pins connector	Remark
CAN_SCR	SAE J1939 shield-E	CAN communication shielding line (connected with ECU terminal only);
CAN(H)	SAE J1939 signal-C	Using impedance 120Ω connecting line;
CAN(L)	SAE J1939 return-D	Using impedance 120Ω connecting line.

Engine type: Cummins QSX15-CM570.

## 21.5 CUMMINS GCS-MODBUS

It is suitable for GCS engine control module. Use RS485-MODBUS to read information of engine. Engine types are QSX15, QST30, QSK23/45/60/78 and so on.

**Table 28 D-SUB Connector 06**

Terminals of controller	D-SUB connector 06	Remark
Aux. output 1	5&8	Configured to "Fuel Relay Output"; Outside expansion relay; at fuel output, make port 05 and port 08 of connector 06 connected;
Start relay output	-	Connected to starter coil directly.

**Table 29 D-SUB Connector 06**

Terminals of controller	D-SUB connector 06	Remark
RS485 GND	20	CAN communication shielding line (connected with ECU terminal only);
RS485+	21	Using impedance 120Ω connecting line;
RS485-	18	Using impedance 120Ω connecting line.

Engine type: Cummins-QSK-MODBUS, Cummins- QST-MODBUS, Cummins-QSX-MODBUS.

## 21.6 CUMMINS QSM11

**Table 30 Engine OEM Connector**

Terminals of controller	OEM connector of engine	Remark
Aux. output 1	38	Configured to "Fuel Relay Output";
Starting relay output	-	Connected with starter coil directly;
CAN_SCR	-	CAN communication shielding line;
CAN(H)	46	Using impedance 120Ω connecting line;
CAN(L)	37	Using impedance 120Ω connecting line.

Engine type: Common J1939.

21.7 CUMMINS QSZ13

Table 31 Engine OEM Connector

Terminals of controller	OEM connector of engine	Remark
Aux. output 1	45	
Starting relay output	-	Connected to starter coil directly;
Aux. output 2	16&41	Set as idling speed control; (N/C) output; by expansion relay, make 16&41 close as the controller is running;
Aux. output 3	19&41	Set as pulse speed raising control; (N/O) output; by expansion relay, make 19&41 close for 1s as the controller is entering warming-up time;
CAN_SCR	-	CAN communication shielding line;
CAN(H)	1	Using impedance 120Ω connecting line;
CAN(L)	21	Using impedance 120Ω connecting line.

Engine type: Common J1939.

21.8 DETROIT DIESEL DDEC III/IV

Table 32 Engine CAN Port

Terminals of controller	CAN port of engine	Remark
Aux. output 1	Expansion 30A relay, proving battery voltage for ECU.	Configured to "Fuel Relay Output";
Starting relay output	-	Connected to starter coil directly;
CAN_SCR	-	CAN communication shielding line;
CAN(H)	CAN(H)	Using impedance 120Ω connecting line;
CAN(L)	CAN(L)	Using impedance 120Ω connecting line.

Engine type: Common J1939.

21.9 DEUTZ EMR2

Table 33 F Connector

Terminals of controller	F connector	Remark
Aux. output 1	Expansion 30A relay, proving battery voltage for terminal 14; Fuse is 16A.	Configured to "Fuel Relay Output";
Starting relay output	-	Connected to starter coil directly;
-	1	Connected to battery negative;
CAN_SCR	-	CAN communication shielding line;
CAN(H)	12	Impedance 120Ω connecting line is recommended;
CAN(L)	13	Impedance 120Ω connecting line is recommended.

Engine type: VOLVO-EDC4.

21.10 JOHN DEERE

Table 34 21-Pin Connector

Terminals of controller	21 pins connector	Remark
Aux. output 1	G, J	Configured to "Fuel Relay Output";
Starting relay output	D	
CAN_SCR	-	CAN communication shielding line;
CAN(H)	V	Using impedance 120Ω connecting line;
CAN(L)	U	Using impedance 120Ω connecting line.

Engine type: JOHN DEERE.

21.11 MTU MDEC

Suitable for MTU engines 2000 series, 4000series.

Table 35 X1 Connector

Terminals of controller	X1 Connector	Remark
Aux. output 1	BE1	Configured to "Fuel Relay Output";
Starting relay output	BE9	
CAN_SCR	E	CAN communication shielding line (Connect with one terminal only);
CAN(H)	G	Using impedance 120Ω connecting line;
CAN(L)	F	Using impedance 120Ω connecting line.

Engine type: MTU-MDEC-303.

## 21.12 MTU ADEC (SMART MODULE)

It is suitable for MTU engine with ADEC (ECU8) and SMART module.

**Table 36 ADEC (X1 Port)**

Terminals of controller	ADEC (X1 port)	Remark
Aux. output 1	X1 10	Configured to "Fuel Relay Output"; X1 9 shall connect negative of battery.
Starting relay output	X1 34	X1 33 shall connect negative of battery.

**Table 37 SMART (X4 Port)**

Terminals of controller	SAM (X4 port)	Remark
CAN_SCR	X4 3	CAN communication shielding line;
CAN(H)	X4 1	Using impedance 120Ω connecting line;
CAN(L)	X4 2	Using impedance 120Ω connecting line.

Engine type: MTU-ADEC.

## 21.13 MTU ADEC (SAM MODULE)

Suitable for MTU engine with ADEC (ECU7) and SAM module.

**Table 38 ADEC (X1 Port)**

Terminals of controller	ADEC (X1 port)	Remark
Aux. output 1	X1 43	Configured to "Fuel Relay Output"; X1 28 shall connect negative of battery.
Starting relay output	X1 37	X1 22 shall connect negative of battery.

**Table 39 SAM (X23 Port)**

Terminals of controller	SAM (X23 Port)	Remark
CAN_SCR	X23 3	CAN communication shielding line;
CAN(H)	X23 2	Using impedance 120Ω connecting line;
CAN(L)	X23 1	Using impedance 120Ω connecting line.

Engine type: Common J1939.

## 21.14 PERKINS

It is suitable for ADEM3/ADEM4 engine control module. Engine type is 2306, 2506, 1106, and 2806.

**Table 40 Connector**

Terminals of controller	Connector	Remark
Aux. output 1	1, 10, 15, 33, 34	Configured to "Fuel Relay Output";
Starting relay output	-	Connected to starter coil directly;
CAN_SCR	-	CAN communication shielding line;
CAN(H)	31	Using impedance 120Ω connecting line;
CAN(L)	32	Using impedance 120Ω connecting line.

Engine type: PERKINS.

## 21.15 SCANIA

It is suitable for S6 engine control module. Engine type is DC9, DC12, and DC16.

**Table 41 B1 Connector**

Terminals of controller	B1 connector	Remark
Aux. output 1	3	Configured to "Fuel Relay Output";
Starting relay output	-	Connected to starter coil directly;
CAN_SCR	-	CAN communication shielding line;
CAN(H)	9	Using impedance 120Ω connecting line;
CAN(L)	10	Using impedance 120Ω connecting line.

Engine type: SCANIA.

## 21.16 VOLVO EDC3

Suitable engine control mode is TAD1240, TAD1241, and TAD1242.

**Table 42 "Stand Alone" Connector**

Terminals of controller	"Stand alone" connector	Remark
Aux. output 1	H	Configured to "Fuel Relay Output";
Starting relay output	E	
Aux. output 2	P	Set to "ECU power".

**Table 43 "Data Bus" Connector**

Terminals of controller	"Data bus" connector	Remark
CAN_SCR	-	CAN communication shielding line
CAN(H)	1	Using impedance 120Ω connecting line;
CAN(L)	2	Using impedance 120Ω connecting line.

Engine type: VOLVO.

**▲NOTE:** When this engine type is selected, preheating time should be set to at least 3 seconds.

**21.17 VOLVO EDC4**

Suitable engine types are TD520, TAD520 (optional), TD720, TAD720 (optional), TAD721, TAD722, and TAD732.

**Table 44 Connector**

Terminals of controller	Connector	Remark
Aux. output 1	Expansion 30A relay, providing battery voltage for terminal 14. Fuse is 16A.	Configured to "Fuel Relay Output";
Starting relay output	-	Connected to starter coil directly;
	1	Connected to negative of battery;
CAN_SCR	-	CAN communication shielding line;
CAN(H)	12	Using impedance 120Ω connecting line;
CAN(L)	13	Using impedance 120Ω connecting line.

Engine type: VOLVO-EDC4.

**21.18 VOLVO-EMS2**

Volvo Engine types are TAD734, TAD940, TAD941, TAD1640, TAD1641, and TAD1642.

**Table 45 Engine CAN Port**

Terminals of controller	Engine's CAN port	Remark
Aux. output 1	6	Set output 1 to "ECU stop";
Aux. output 2	5	Set output 2 to "ECU power";
	3	Power negative;
	4	Power passive;
CAN_SCR	-	CAN communication shielding line;
CAN(H)	1(Hi)	Using impedance 120Ω connecting line;
CAN(L)	2(Lo)	Using impedance 120Ω connecting line.

Engine type: VOLVO-EMS2.

**▲NOTE:** When this engine type is selected, preheating time should be set to at least 3 seconds.

**21.19 YUCHAI**

It is suitable for BOSCH common rail electronic-controlled engine.

**Table 46 Engine 42-Pin Port**

Terminals of controller	Engine 42 pins port	Remark
Aux. output 1	1.40	Configured to "Fuel Relay Output"; Connected to engine ignition lock;
Starting relay output	-	Connected to starter coil directly;
CAN_SCR	-	CAN communication shielding line;
CAN(H)	1.35	Using impedance 120Ω connecting line;
CAN(L)	1.34	Using impedance 120Ω connecting line.

**Table 47 Engine 2-Pin Port**

Battery	Engine 2 pins port	Remark
Battery negative	1	Wire diameter 2.5mm <sup>2</sup> ;
Battery positive	2	Wire diameter 2.5mm <sup>2</sup> .

Engine type: BOSCH.

**21.20 WEICHAI**

It is suitable for Weichai BOSCH common rail electronic-controlled engine.

**Table 48 Engine Port**

Terminals of controller	Engine port	Remark
Aux. output 1	1.40	Configured to "Fuel Relay Output"; Connected to engine ignition lock;
Starting relay output	1.61	
CAN_SCR	-	CAN communication shielding line;
CAN(H)	1.35	Using impedance 120Ω connecting line;
CAN(L)	1.34	Using impedance 120Ω connecting line.

Engine type: GTSC1.

**▲NOTE:** If there is any question of connection between controller and ECU communication, please feel free to contact SmartGen's service.

22 FAULT FINDING

Table 49 Fault Finding

Symptoms	Possible Solutions
Controller no response for power	Check starting batteries; Check controller connection wirings; Check DC fuse.
Genset shutdown	Check the water/cylinder temperature is too high or not; Check the genset AC voltage; Check DC fuse.
Controller emergency stop	Check emergence stop button is correct or not; Check whether the starting battery positive is connected with the emergency stop input; Check whether there is open circuit.
Low oil pressure alarm after crank disconnect	Check the oil pressure sensor and its connections.
High water temperature alarm after crank disconnect	Check the water temperature sensor and its connections.
Shutdown alarm in running	Check related switch and its connections according to the information on LCD; Check digital inputs.
Crank disconnect failure	Check fuel circuit and its connections; Check starting batteries; Check speed sensor and its connections; Refer to engine manual.
No response for starter	Check starter connections; Check starting batteries.
Genset is running but ATS does not transfer	Check ATS; Check the connections between ATS and controllers.
RS485 communication abnormal	Check connections; Check settings of COM port is correct or not; Check RS485's A and B connections is reversely connected or not; Check RS485 conversion module is damaged or not; Check communication port of PC is damaged or not.
ECU communication failure	Check the polarity of CAN high and CAN low; Check 120Ω terminal resistor is correctly connected or not; Check engine type is correctly chosen or not; Check whether the connection between controller and engine is correct, output setting is correct or not.
ECU alarm	Get information from LCD alarm page; If there is detailed alarm information, check the engine according to the description. If not, please refer to engine manual according to SPN alarm code.

Table 50 Order Model

Order Model	Country/Region	Frequency Band	Remark
HGM9420N-S01 HGM9420LT-S01	Chinese Mainland and Southeast Asia	FDD-LTE: B1/B3/B8 TDD-LTE: B38/B39/B40/B41 TD-SCDMA: B34/B39 WCDMA: B1/B8 EVDO/CDMA: BC0 GSM: 900/1800MHz	SGE02-4G
HGM9420N-S02 HGM9420LT-S02	North America	FDD-LTE: B2/B4/B12 WCDMA: B2/B5	SGE02-4G-S01
HGM9420N-S03 HGM9420LT-S03		FDD-LTE: B2/B4/B5/B13	SGE02-4G-S02
HGM9420N-S04 HGM9420LT-S04	Europe/Africa/South Korea/Thailand/Middle East	FDD-LTE: B1/B3/B5/B7/B8/B20 TDD-LTE: B38/B40/B41 WCDMA: B1/B5/B8 GSM: 900/1800MHz	SGE02-4G-S03
HGM9420N-S05 HGM9420LT-S05	South America/Australia/ New Zealand	FDD-LTE: B1/B2/B3/B4/B5/B7/B8/B28 TDD-LTE: B40 WCDMA: B1/B2/B5/B8 GSM: 850/900/1800/1900MHz	SGE02-4G-S04
HGM9420N-S06 HGM9420LT-S06	Japan	FDD-LTE: B1/B3/B8/B18/B19/B26	SGE02-4G-S05
HGM9420N-G HGM9420LT-G	All Regions	FDD-LTE: B1/B2/B3/B4/B5/B7/B8/B12/ B13/B18/B19/B20/B26/B28 TDD-LTE: B38/B39/B40/B41 TD-SCDMA: B34/B39 WCDMA: B1/B2/B5/B8 EVDO/CDMA: BC0 GSM: 850/900/1800/1900MHz	SGE02-4G-G