

# APPLICATION AND INSTALLATION GUIDE

## **EMCP 4.1, 4.2 GENERATOR SET CONTROL**

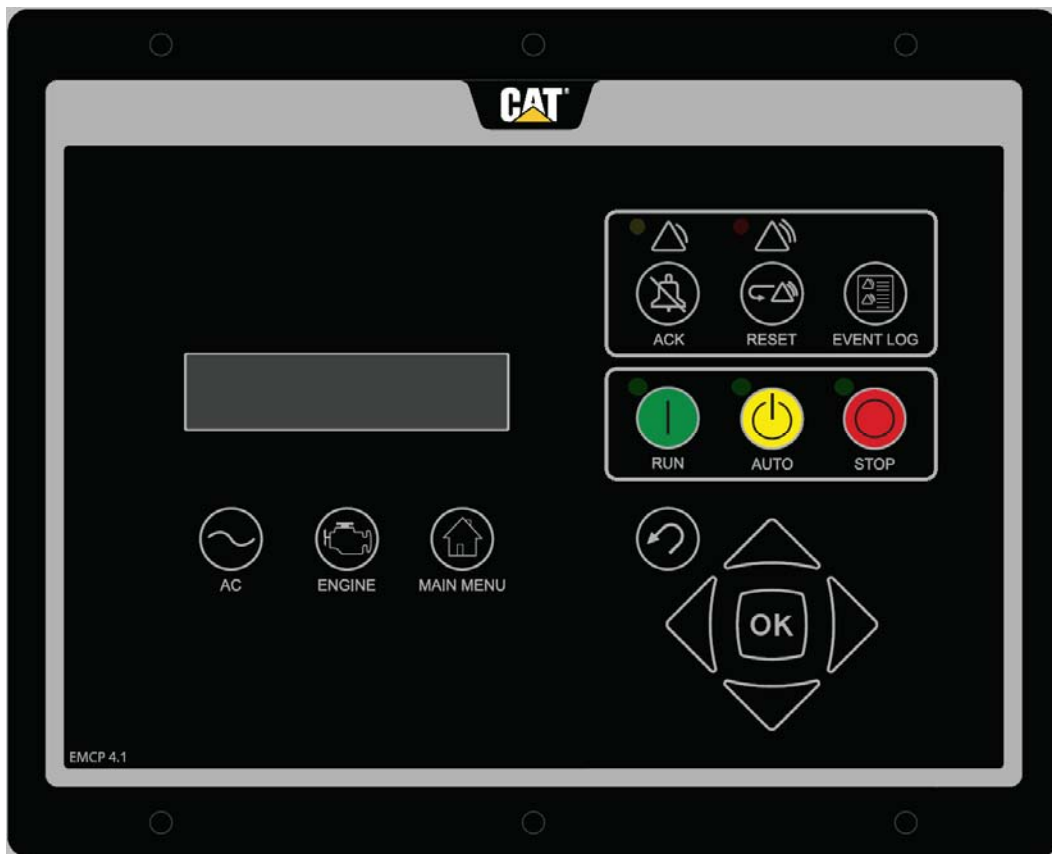



# Contents

<b>1</b>	<b>GENERAL INFORMATION.....</b>	<b>1</b>
1.1	INTRODUCTION .....	1
1.2	APPLICATIONS .....	1
1.3	REFERENCES .....	1
<b>2</b>	<b>SAFETY INFORMATION.....</b>	<b>2</b>
2.1	ELECTRICAL SAFETY .....	2
2.2	ELECTROSTATIC DISCHARGE AWARENESS.....	2
<b>3</b>	<b>INSTALLATION.....</b>	<b>3</b>
3.1	MOUNTING LOCATION .....	3
3.2	OPERATING TEMPERATURE RANGE .....	3
3.3	POWER REQUIREMENTS.....	3
3.4	BATTERY CHARGER.....	4
3.5	ELECTRICAL CONNECTIONS.....	5
3.6	EUI ENGINES .....	5
3.7	EMCP 4.1 AND 4.2 ELECTRICAL DIAGRAMS .....	6
3.8	WINDING CONNECTIONS.....	8
3.9	TRANSFORMER CONNECTIONS.....	9
3.10	WIRING REQUIREMENTS.....	11
3.11	SHIELDED AND COMMUNICATION WIRING .....	13
<b>4</b>	<b>INITIAL OPERATION AND USER ORIENTATION .....</b>	<b>14</b>
4.1	TYPES OF EMCP 4 EVENTS.....	14
4.2	USING THE CAT SERVICE TOOL.....	14
	Connecting to the EMCP 4 to Configure Setpoints.....	15
4.3	VIEWING SYSTEM PARAMETERS.....	16
	Supported Parameters.....	17
	Engine Overview .....	17
	AC Overview .....	20
4.4	VIEWING AND ADJUSTING PREFERENCES.....	21
	Setting The Preferences Using The EMCP 4 Display.....	22
	Changing The EMCP 4 Contrast When the Display is Unreadable .....	24
	Changing The EMCP 4 Display to Technician English .....	24
	Changing The EMCP 4 Display to the Primary Language .....	25
	Setting the Preferences Using the Service Tool.....	25
4.5	CONFIGURING TIME/DATE (EMCP 4.2 ONLY).....	26
	Changing The Time / Date.....	26
	Changing Date Format .....	28
4.6	ADJUSTING GENERATOR SET PARAMETERS.....	29
	Generator Output Voltage.....	29
	Engine Speed .....	29
	Idle/Rated .....	30
	Engine Sensor Versus Data link.....	31
	Engine Oil Pressure.....	33
	Engine Coolant Temperature.....	36
4.7	STARTING AND STOPPING THE GENERATOR SET .....	38
	Starting The Engine.....	38
	EMCP 4 Remote Start .....	39
	Stopping The Engine .....	39

	Emergency Stop.....	41
	EMCP 4 Remote Stop .....	42
<b>4.8</b>	<b>ENGINE SETPOINT VERIFICATION .....</b>	<b>43</b>
	Procedure For Overspeed Verification.....	43
	Procedure For Low Oil Pressure Verification .....	44
	Procedure For High Coolant Temperature Verification .....	44
<b>4.9</b>	<b>ENGINE OPERATING HOURS .....</b>	<b>45</b>
	Updating Engine Operating Hours.....	45
<b>5</b>	<b>HANDLING EVENTS .....</b>	<b>47</b>
<b>5.1</b>	<b>CONFIGURING EVENT RESPONSES FOR EMCP 4 GENERATED EVENTS.....</b>	<b>48</b>
<b>5.2</b>	<b>CHANGING AN EVENT RESPONSE CONFIGURATION.....</b>	<b>50</b>
<b>5.3</b>	<b>RESETTING INDIVIDUAL ACTIVE EVENTS FOR THE EMCP 4 .....</b>	<b>53</b>
<b>5.4</b>	<b>RESETTING ALL ACTIVE EVENTS FOR A SINGLE MODULE .....</b>	<b>54</b>
<b>5.5</b>	<b>RESETTING ALL ACTIVE EVENTS FOR ALL MODULES .....</b>	<b>55</b>
<b>5.6</b>	<b>RESETTING EVENTS FOR ENGINE ECMs WITHOUT PRIMARY CAN DATA LINK SUPPORT .....</b>	<b>56</b>
<b>5.7</b>	<b>TROUBLESHOOTING RESETTING EVENTS .....</b>	<b>56</b>
	Not in Auto Warning .....	56
	Service Maintenance Interval (EMCP 4.2 Only) .....	56
<b>6</b>	<b>SECURITY .....</b>	<b>61</b>
<b>7</b>	<b>SETPOINTS .....</b>	<b>65</b>
<b>7.1</b>	<b>CONFIGURING SETPOINTS .....</b>	<b>65</b>
<b>7.2</b>	<b>SETPOINTS ON THE EMCP 4 DISPLAY .....</b>	<b>67</b>
<b>7.3</b>	<b>SETPOINTS ON THE CAT SERVICE TOOL.....</b>	<b>67</b>
	Setpoint Categories.....	68
<b>8</b>	<b>DIGITAL INPUTS.....</b>	<b>71</b>
<b>8.1</b>	<b>PROGRAMMING DIGITAL INPUTS USING THE DISPLAY .....</b>	<b>72</b>
	Viewing the Current Digital Input Status .....	73
	Configuring Digital Inputs for Status Parameters.....	74
	Configuring Digital Inputs for System Events .....	76
	Configuring Digital Inputs for SCADA Data link.....	79
	Disabling Digital Inputs .....	80
<b>8.2</b>	<b>PROGRAMMING DIGITAL INPUTS USING THE CAT SERVICE TOOL .....</b>	<b>81</b>
	Configuring Digital Inputs for Status Parameter .....	82
	Configuring Digital Inputs for System Events .....	83
	Configuring Digital Inputs for SCADA Data link.....	87
	Disabling Digital Inputs .....	87
<b>9</b>	<b>ANALOG INPUTS.....</b>	<b>88</b>
<b>9.1</b>	<b>PROGRAMMING ANALOG INPUTS USING THE DISPLAY .....</b>	<b>90</b>
	Viewing the Current Analog Input Status .....	90
	Configuring Analog Inputs for Resistive Mode.....	91
	Configuring Analog Inputs for Voltage Mode.....	93
	Disabling Analog Inputs .....	95
<b>9.2</b>	<b>PROGRAMMING ANALOG INPUTS USING THE CAT SERVICE TOOL .....</b>	<b>95</b>
	Configuring Analog Inputs for Resistive Mode.....	96
	Configuring Analog Inputs for Voltage Mode.....	99
	Disabling Analog Inputs .....	102
<b>9.3</b>	<b>ANALOG INPUT MAPS .....</b>	<b>103</b>
	Warnings and Shutdowns.....	111
	Unsupported Analog Input Sensor Ranges.....	111
	Sensor Range is Smaller than Setpoint Options .....	111
	Sensor Range is Larger than Setpoint Options, But Usable Range is Not.....	112

	Sensor Range is Larger than Setpoint Options, And Usable Range is Larger Than Setpoint Options....	113
<b>10</b>	<b>OUTPUTS</b> .....	<b>114</b>
<b>10.1</b>	<b>PROGRAMMING OUTPUTS USING THE DISPLAY</b> .....	<b>115</b>
	Viewing the Current Output Status .....	115
	Configuring Outputs for Status Parameters .....	115
	Configuring Outputs for System Events .....	117
	Configuring Outputs for SCADA Data link.....	120
	Disabling Outputs .....	121
<b>10.2</b>	<b>PROGRAMMING OUTPUTS USING THE CAT SERVICE TOOL</b> .....	<b>121</b>
	Configuring Outputs for Status Parameters .....	122
	Configuring Outputs for System Events .....	124
	Configuring Outputs for SCADA Data link.....	125
	Disabling Outputs .....	126
<b>11</b>	<b>MODIFIABLE TEXT STRINGS</b> .....	<b>127</b>
<b>11.1</b>	<b>LANGUAGE SUPPORT</b> .....	<b>128</b>
<b>11.2</b>	<b>PROGRAMMING MODIFIABLE TEXT STRINGS USING THE CAT SERVICE TOOL</b> .....	<b>128</b>
<b>12</b>	<b>SAVING AND RESTORING SETPOINTS</b> .....	<b>132</b>
<b>12.1</b>	<b>SAVING EMCP 4 CONFIGURATION DATA</b> .....	<b>132</b>
	Fleet Configuration Option .....	133
	ECM Replacement Option .....	133
<b>12.2</b>	<b>LOADING EMCP 4 CONFIGURATION DATA</b> .....	<b>135</b>
<b>13</b>	<b>PROGRAMMABLE CYCLE TIMER (EMCP 4.2 ONLY)</b> .....	<b>138</b>
<b>13.1</b>	<b>CONFIGURING THE PROGRAMMABLE CYCLE TIMER USING THE DISPLAY</b> .....	<b>140</b>
<b>13.2</b>	<b>CONFIGURING THE PROGRAMMABLE CYCLE TIMER USING THE CAT SERVICE TOOL</b> .....	<b>141</b>
<b>14</b>	<b>REDUCED POWER MODE</b> .....	<b>145</b>
<b>15</b>	<b>PROGRAMMABLE KW RELAY FUNCTION (EMCP 4.2 ONLY)</b> .....	<b>147</b>
<b>15.1</b>	<b>CONFIGURING THE PROGRAMMABLE KW RELAY FROM THE DISPLAY</b> .....	<b>148</b>
<b>15.2</b>	<b>CONFIGURING THE PROGRAMMABLE KW RELAYS USING THE CAT SERVICE TOOL</b> .....	<b>150</b>
<b>16</b>	<b>CAN DATA LINKS</b> .....	<b>153</b>
<b>16.1</b>	<b>PRIMARY CAN DATA LINK (CAN 1)</b> .....	<b>153</b>
	Primary CAN Wiring .....	153
	Network Topology .....	153
<b>16.2</b>	<b>ACCESSORY CAN DATA LINK (CAN 2) (EMCP 4.2 ONLY)</b> .....	<b>155</b>
	Accessory CAN Wiring .....	155
	Network Topology .....	155
<b>17</b>	<b>OPTIONAL MODULES</b> .....	<b>157</b>
<b>17.1</b>	<b>CAN ANNUNCIATOR</b> .....	<b>158</b>
	CAN Annunciator Features .....	158
	Annunciator Specifications.....	159
	Annunciator Wiring .....	160
	LED Colors .....	161
	CAN Annunciator Software Configuration.....	162
	Global Acknowledge .....	162
	ECU Instance Number.....	162
	Configuring Annunciator LED Behavior .....	162
	Trigger Condition.....	165
	Severity Level.....	166
	Suspect Parameter Number.....	167
<b>17.2</b>	<b>RS-485 ANNUNCIATOR (EMCP 4.2 ONLY)</b> .....	<b>167</b>

	Annunciator Features .....	168
	Annunciator Specifications.....	168
	RS-485 Annunciator Wiring.....	169
	LED Colors .....	170
	Lamp Test Function.....	171
	Alarm Acknowledge.....	171
	RS-485 ANNUNCIATOR ALARM GROUPS.....	172
	Alarm Group Selection Mode (AGSM).....	172
	Entering AGSM .....	172
	Re-configuring/Selecting Alarm Group Address.....	173
	Exiting AGSM.....	173
	RS-485 Annunciator Custom Alarm Group Configuration.....	174
	CUSTOM ALARM GROUP SELECTION.....	174
	Severity Level.....	175
	Suspect Parameter Number.....	175
	Alarm Groups.....	176
	Configuring Custom Alarm Groups using Cat Service Tool.....	179
<b>17.3</b>	<b>THERMOCOUPLE MODULE (EMCP 4.2 ONLY) .....</b>	<b>186</b>
	Thermocouple Features.....	186
	Thermocouple Specifications .....	187
	Thermocouple Wiring.....	188
	Thermocouple Physical Layout .....	189
	Thermocouple Module – Configuration.....	189
	Configuring Thermocouple Inputs.....	191
<b>17.4</b>	<b>RTD MODULE (EMCP 4.2 ONLY) .....</b>	<b>192</b>
	RTD Features.....	192
	RTD Specifications.....	193
	RTD Wiring .....	194
	RTD Physical Layout.....	195
	RTD Module – Configuration.....	195
	Configuring RTD Inputs .....	196
<b>17.5</b>	<b>DISCRETE I/O MODULE (EMCP 4.2 ONLY) .....</b>	<b>197</b>
	Discrete I/O Features.....	197
	Discrete I/O Specifications.....	198
	Discrete I/O Wiring .....	199
	Discrete I/O Physical Layout .....	200
	Discrete I/O Software Configuration .....	200
	Configuring Digital Inputs.....	202
	Configuring Relay Outputs.....	203
<b>18</b>	<b>SCADA (MODBUS) DATA LINK (EMCP 4.2 ONLY) .....</b>	<b>204</b>
<b>18.1</b>	<b>WIRING.....</b>	<b>204</b>
<b>18.2</b>	<b>LINE TERMINATION .....</b>	<b>206</b>
<b>18.3</b>	<b>SOFTWARE CONFIGURATION .....</b>	<b>206</b>
	Configuring The SCADA Data Link Using The Display .....	206
	Configuring The SCADA Data Link Using The Cat Service Tool .....	207
<b>19</b>	<b>INSTALLING &amp; UPGRADING SOFTWARE.....</b>	<b>210</b>
	<b>APPENDIX A MENU STRUCTURES .....</b>	<b>214</b>
	<b>APPENDIX B EMCP 4 FRONT VIEW &amp; NAVIGATION KEYS.....</b>	<b>216</b>

# Foreword

This Application and Installation Guide describes the EMCP 4.1 and 4.2 series electric power generator set controls.

Some data used in this guide is generalized and is provided only for the purpose of comparison or illustration. Also, PC application screenshots and EMCP 4 screen images may be actual screens or simulated and are shown for illustrative purposes only. These images may not be identical to those seen by the user. Screen images of the EMCP 4 may differ from the actual screens depending on flash file language, setpoint configuration, or series of the EMCP (4.1 versus 4.2).

In various places throughout this document, reference is made to the release date of the EMCP 4 software. This information can be found by connecting to the subject module using the Cat Service Tool, and viewing the ECM Summary (this is the default startup screen). The release date is found in the field entitled Software Group Release Date. See Figure 1, showing the release date for a Thermocouple module.

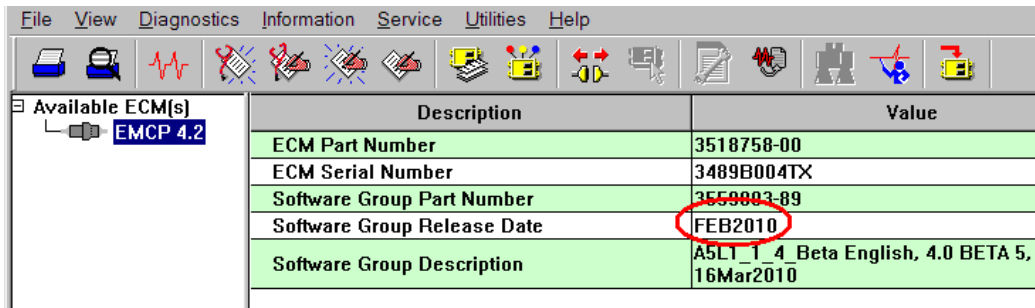

Description	Value
ECM Part Number	3518758-00
ECM Serial Number	3489B004TX
Software Group Part Number	3558803-89
Software Group Release Date	FEB2010
Software Group Description	A5LT_1_4_Beta English, 4.0 BETA 5, 16Mar2010

**Figure 1: EMCP Software Release Date**

Other product specific information and data is available from a variety of sources. For more information, contact the Cat® dealer or dealer TC nearest you.

The information in this document is the property of Caterpillar Inc. and/or its subsidiaries. Any copying, distribution, transmission to others, and any use except that for which it is loaned is prohibited without written permission.

CAT, CATERPILLAR, ADEM™, their respective logos, "Caterpillar Yellow," the "Power Edge" trade dress as well as corporate and product identity used herein, are trademarks of Caterpillar and may not be used without permission.



---

# 1 GENERAL INFORMATION

## 1.1 INTRODUCTION

Caterpillar has developed a product line of Generator Set Controls for use in the Electronic Modular Control Panel 4 (EMCP 4). They are available in four versions based on Generator Set Control feature sets.

The EMCP 4 Generator Set Control, or GSC, is the primary controller within the Generator Set Control system. The EMCP 4 line of Generator Set Controllers includes EMCP 4.1, 4.2, 4.3, and 4.4. Appendix B shows a full view of the EMCP 4.1 and 4.2.

This Application and Installation Guide is intended to cover the EMCP 4.1 and 4.2 Generator Set Control and its application in generator set systems. It also includes information on optional add-on modules. The intended audience for this guide includes Cat generator set system designers, Caterpillar service support personnel, Cat Dealers and Service Technicians, contractors, and customers.

## 1.2 APPLICATIONS

The EMCP 4 product line of generator set controllers is designed for use in a wide range of applications. They can be used on standby and prime Cat brand power diesel generator sets. The configurability of the controllers allows them to be used, in some cases, on other applications such as Marine auxiliary generators, switchgear applications, industrial engines and generator sets, and gas generator sets.

Most of the information in this document applies to all applications. However, the document was written with Cat brand diesel generator sets in mind. Please contact your Cat support representative for questions regarding different applications.

## 1.3 REFERENCES

The System Operation Testing, Troubleshooting, and Adjusting manual (UENR 1209) is also available for EMCP 4.1 and 4.2 Generator Set Controls. The genset Operations and Maintenance manual contains details for specific products.

## 2 SAFETY INFORMATION

### 2.1 ELECTRICAL SAFETY

**DO NOT** operate or work on a generator set unless you have read and understand the instructions and warnings in the Operation and Maintenance Manual. Failure to follow the instructions or heed the warnings could result in injury or death. Contact any Cat dealer for replacement manuals. Proper care is your responsibility.



### 2.2 ELECTROSTATIC DISCHARGE AWARENESS

EMCP 4 control contains components that are sensitive to **ELECTROSTATIC DISCHARGE (ESD)**. An electrostatic charge can damage the control resulting in EMCP 4 breakdown or improper operation.

Take the following precautions while installing/removing/handling the control:

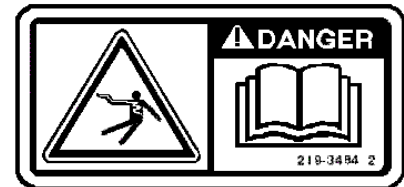

- Handle equipment correctly. Use ESD protective packaging and material handling containers that are anti-static and provide discharge protection and electric field suppression.
- Use protective devices: ESD-protective workstations and/or work surfaces (grounding mat, anti-static wrist strap, etc).
- Keep all plastic items away from the devices. Any plastic item is a potential static generator. This includes candy wrappers, foam cups, synthetic carpet, foam cushions, etc.
- The anti-static bag cannot function as a static dissipating mat.
- **DO NOT** use an anti-static bag for any other purpose than to enclose a product.

**Caution:** The 70-pin connector on the back of the control is the most vulnerable area to **ELECTROSTATIC DISCHARGE (ESD)**. While handling the EMCP 4, extra attention is required to the back of the control. The control may become damaged or inoperable if extra care is not taken.

Consult the Electrostatic Discharge Association for proper procedure during particular situations: <http://www.esda.org>

---

## 3 INSTALLATION

### 3.1 MOUNTING LOCATION

When selecting a mounting location for the EMCP 4, consider the following:

- Protection from high-voltage and high-current devices.
- Protection from devices which may produce electromagnetic interference.
- Protection from excessive vibration. The EMCP 4 controls are designed to withstand normal generator set vibrations. They should not be mounted directly to the engine block.
- Protection from direct exposure to water. Once installed, the EMCP 4 controllers are sealed to a level of IP Level 56 for resistance to moisture.

Suitable for Flat Surface Mounting in a Type 1 Enclosure only.

### 3.2 OPERATING TEMPERATURE RANGE

EMCP 4 has a continuous operating temperature range of  $-20^{\circ}\text{C}$  to  $+70^{\circ}\text{C}$  ambient.

### 3.3 POWER REQUIREMENTS

The EMCP 4.1 and 4.2 require a nominal voltage of 12 VDC or 24 VDC. If batteries are used for operating power, a charging source such as an alternator or dual-mode battery charger is necessary to maintain a stable supply voltage. The maximum power consumption of the EMCP 4.1 and 4.2 with all I/O at maximum power drain will not exceed 5A at 12VDC, or 3.5A at 24VDC.

Regional electrical codes must be followed. In the case of standby operation, follow the regional requirements for installing standby power systems. An example of this is the National Fire Protection Association (NFPA) guidelines for emergency power systems.

When connecting the EMCP 4 to the DC power source, make sure that there is only one common connection to the negative potential of the power source. Make extra effort to avoid any ground loops in the DC electrical system. A single point common ground for sensitive electronics is recommended at the negative battery terminal or Power Distribution Box.

Avoid daisy-chaining power supply connections from one device to another. This builds resistance from one Battery (-) point to the next, effectively building a potential difference between two different reference points. Each electronics subsystem and major engine subsystem should have its own DC network so that they do not interfere with each other (see Figure 2).

As shown in Figure 2, all sensitive electronics are electrically isolated from higher current loads, such as the starter motor. All electronics have a **COMMON POWER BUS** and **SINGLE POINT REFERENCE**. This point is the genset customer ground connection. The **CHASSIS GROUND** should be bonded separately to the customer ground connection and not be used as the electronics reference.

The sensitive electronics, such as sensors and control modules, have isolated power source paths. High current loads such as starters and solenoids can cause interference and possibly damage to low current loads, such as controllers and sensors.

**Caution:** Extra effort must be made to keep the high current and low current loads electrically separated.

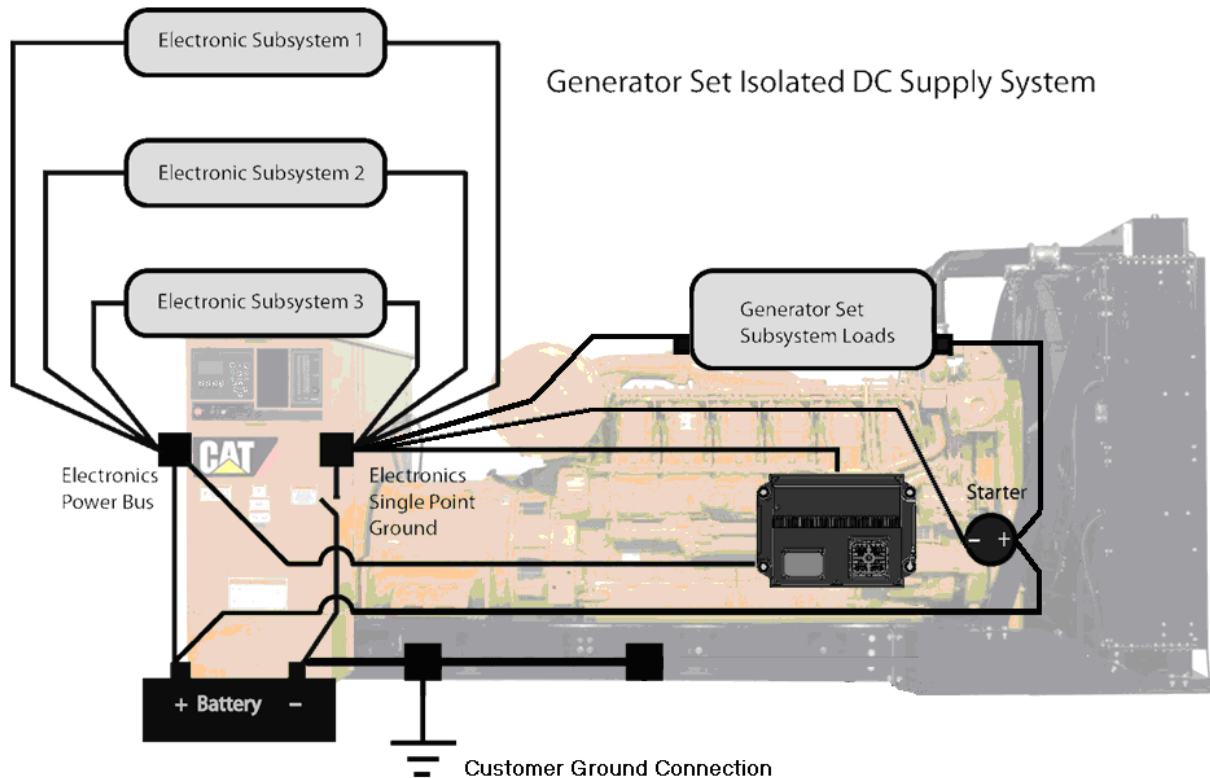

**Figure 2: Generator Set Network Isolation**

The two types of loads may share common Battery (+) and Battery (-) connections but, they should not be electrically connected at any other point. This strategy ensures maximum isolation between high current and low current loads.

The battery **DISCONNECT SWITCH** is usually located on the negative side of the battery supply.

### 3.4 BATTERY CHARGER

If a battery charger is to be used, it should be connected on the battery side of the disconnect switch. Most battery chargers are not to be used as power supplies. Proper battery charger operation requires that the actual battery load be present.

If battery charger fault condition wiring is connected to the EMCP Digital Inputs and these Digital Inputs are set to **DISABLED**, then any battery charger faults or events will not be broadcast or annunciated on the network. See Chapter 8.

### 3.5 ELECTRICAL CONNECTIONS

The EMCP 4.1 and 4.2 share the same 70-pin connector on the back of the controller (not all of the 70 pins are used). The 70-pin connector on the EMCP 4.4 is not the same as the 70-pin connector on the EMCP 4.1 and 4.2.

Figure 3 and Figure 4 shows:

- All possible connections
- What pins are used for connections
- How each pin is connected for each controller version

### 3.6 EUI ENGINES

For EUI engines, the Oil Pressure and Coolant Temperature sensors will typically be wired to the engine ECM and the EMCP 4 will get that information from the engine ECM via the Primary CAN Data Link. Ensure the EMCP 4 Oil Pressure and Coolant Temperature setpoints are configured for Data Link.

In order for the genset to function properly in Cooldown mode, some setpoints in the EMCP 4 must be coordinated with some ADEM setpoints. For gensets where the engine ECM controls cooldown, the cooldown time should be set to 0 seconds in the EMCP. For gensets where the engine ECM does not control cooldown, the cooldown time should be set to 0 seconds in the engine ECM.

### 3.7 EMCP 4.1 AND 4.2 ELECTRICAL DIAGRAMS

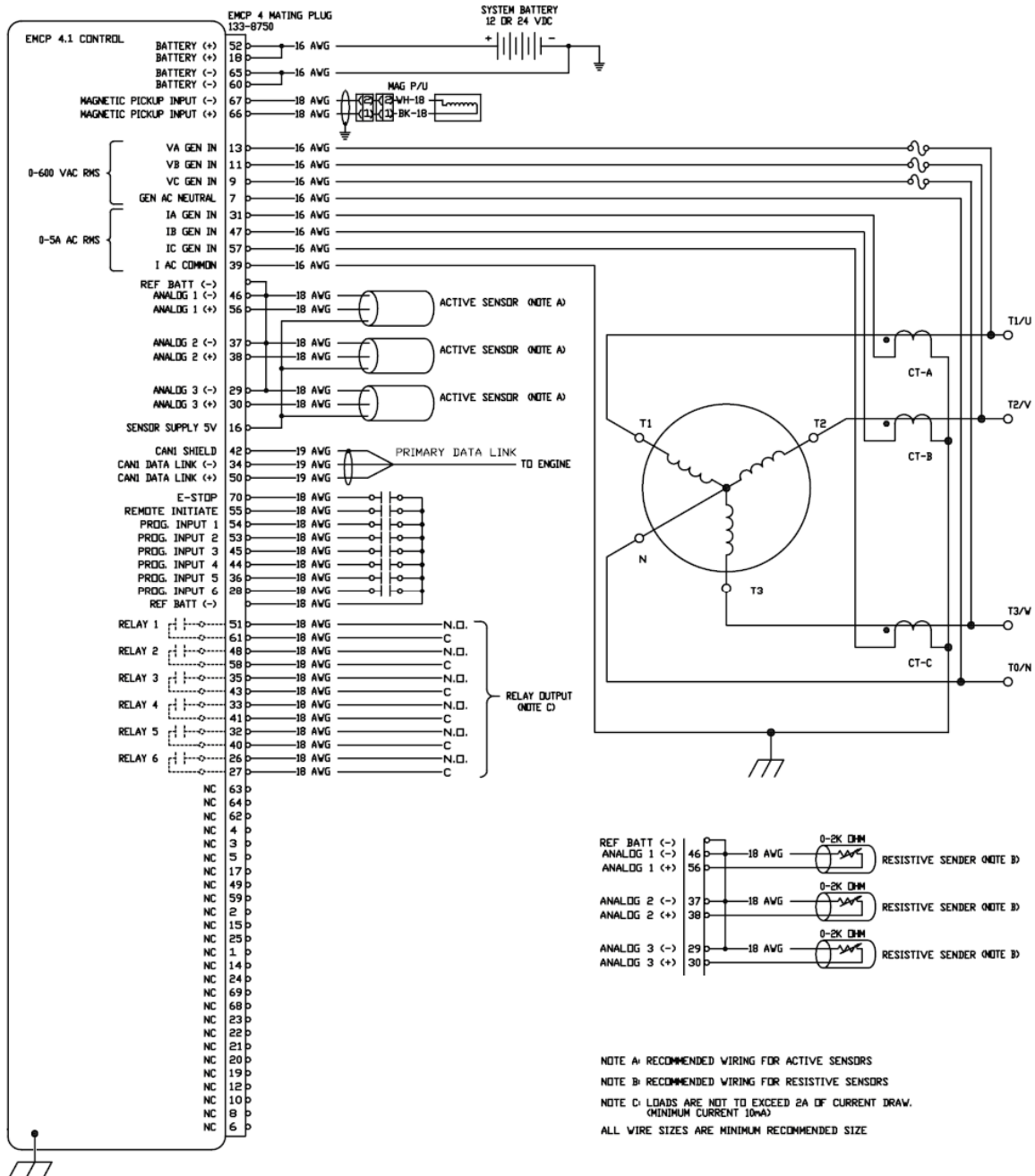

**Figure 3: EMCP 4.1 Wiring Diagram**

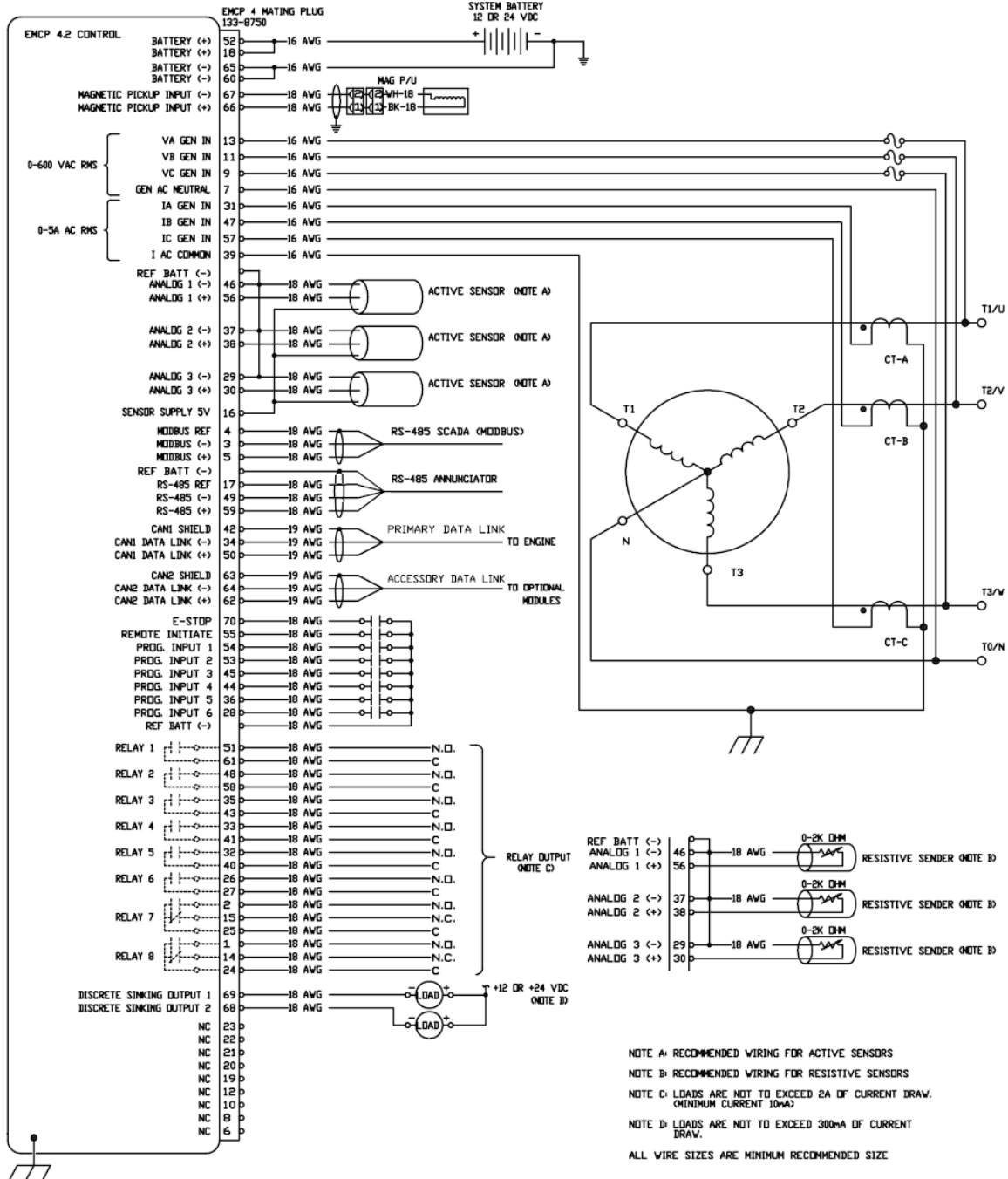

**Figure 4: EMCP 4.2 Wiring Diagram**

### 3.8 WINDING CONNECTIONS

The connections between the generator and the EMCP 4 depend on the winding configuration as shown in the connection diagrams below.

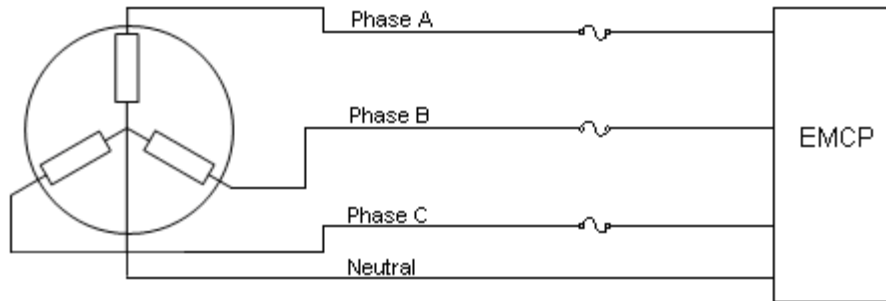

**Figure 5: Three Phase Four Wire (Series Or Parallel) Wye (Star)**

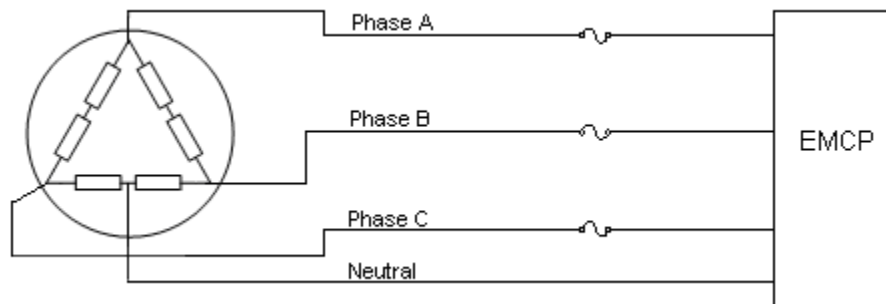

**Figure 6: Three Phase Four Wire Delta**

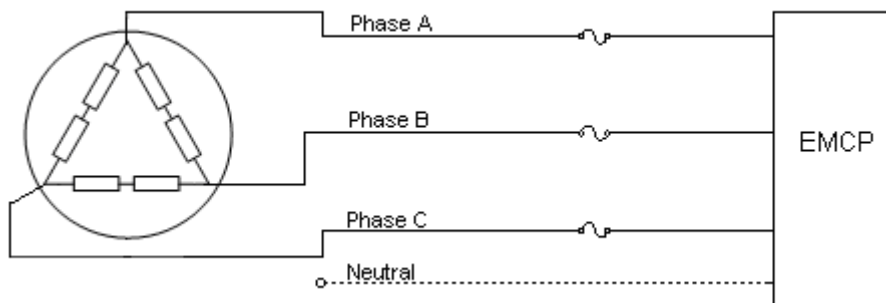

**Figure 7: Three Phase Three Wire Delta**

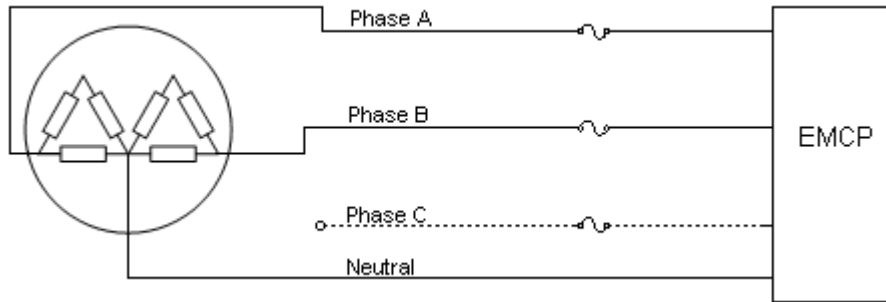

**Figure 8: Single Phase Three Wire, Double Delta**

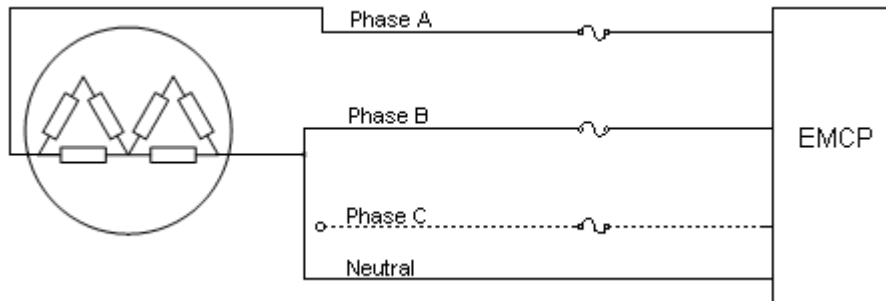

**Figure 9: Single Phase Two Wire, Double Delta**

### 3.9 TRANSFORMER CONNECTIONS

In order to monitor generator output voltages greater than 600 Volts nominal, external potential transformers must be used.

**Note:** The EMCP 4 must be programmed for the correct winding ratios when connecting external potential transformers. See Chapter 7, Setpoints for more information on how to program the winding ratios. If delta potential transformers are used on a wye generator, the EMCP must be programmed for a delta generator.

**Caution:** The **WYE** configuration of external potential transformers is preferred for 4-wire wye generators because of the greater accuracy when loads are unbalanced. With the open delta configuration, some power parameters can not be determined. These parameters are power phase A, B, C and power factor phase A, B, C. For maximum accuracy, the open delta configuration of external potential transformers should be used only for 3-wire delta generators. See Table 1: Power Values Available by Generator Configuration.

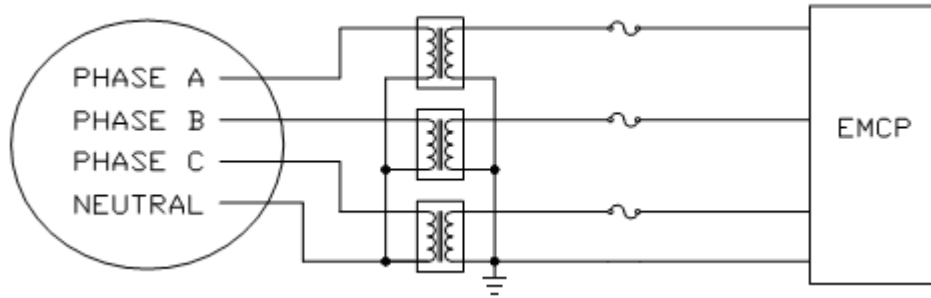

(PT) on the 4-Wire Wye Connected Generator

**Figure 10: Wye Configuration Of External Potential Transformers**

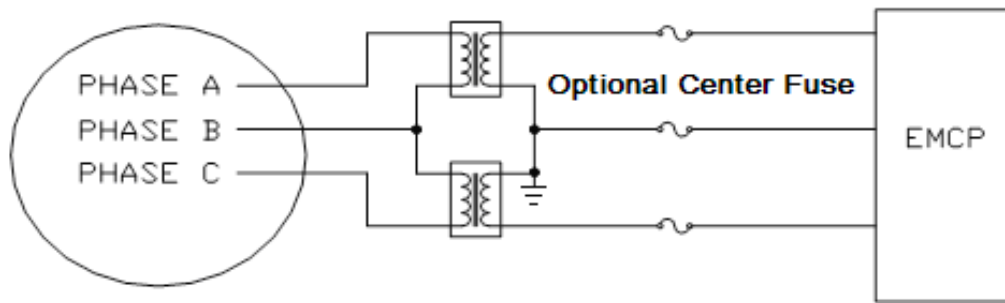

(PT) on the 3-Wire Delta Connected Generator

**Figure 11: Open Delta Configuration Of External Potential Transformers**

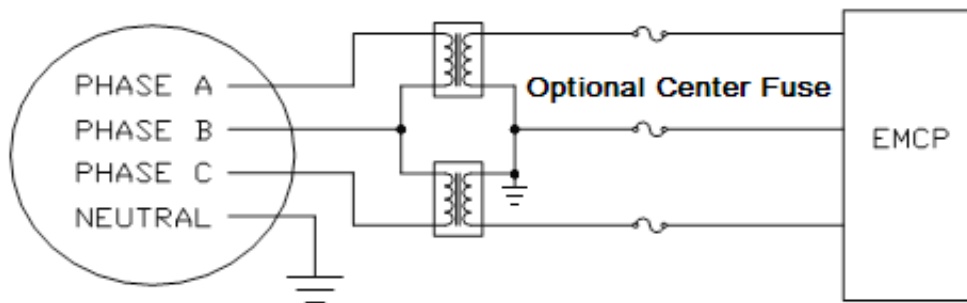

(PT) on the 4-Wire Wye Connected Generator

**Figure 12: Open Delta Configuration Of External Potential Transformers**

TRANSFORMER CONNECTIONS					
Parameter	STAR	3-WIRE DELTA	4-WIRE DELTA	2-WIRE 1-PHASE	3-WIRE 1-PHASE
Gen Freq	Available	Available	Available	Available	Available
$V_{L-L AVG}$	Available	Available	Available	Available	Available
$V_{A-B}$	Available	Available	Available	Available	Available
$V_{B-C}$	Available	Available	Available	Not Available	Not Available
$V_{C-A}$	Available	Available	Available	Not Available	Not Available
$V_{L-N AVG}$	Available	Available	Available	Not Available	Available
$V_A$	Available	Not Available	Available	Not Available	Available
$V_B$	Available	Not Available	Available	Not Available	Available
$V_C$	Available	Not Available	Available	Not Available	Not Available
$I_{AVG}$	Available	Available	Available	Available	Available
$I_A$	Available	Available	Available	Available	Available
$I_B$	Available	Available	Available	Available	Available
$I_C$	Available	Available	Available	Not Available	Not Available

**Table 1: Power Values Available by Generator Configuration**

**Note:** Accuracy of the potential and current transformers will affect the accuracy of the voltage and current readings.

### 3.10 WIRING REQUIREMENTS

When selecting the type of wire to use, consideration must be given to the wire voltage drop, (line loss), accuracy, communication error, and other requirements. See Table 2.

Component	Min Wire Size (AWG)	Type of Wire	Connections <sup>(1)</sup>
Three-Wire Sensors (When applicable. Not used on all systems)	16	Shielded twisted triad cable is recommended. For conduits inside facilities, use Belden 8618. For the engine harness, use the 4G-2556 Shielded Cable. The cable must be resistant to fuel and oil. The cable must have a temperature range from -40°C (-40°F) to plus 125°C (257°F).	Deutsch DT type of connectors are recommended. If Spring Spade or Ring Terminals are used, the connection between the terminals and the wire should be crimped and soldered.
Two-Wire Components (Magnetic Speed Sensors)	16 or 18	Shielded twisted pair cable is recommended. For conduits inside facilities, use the 123-2376 Electrical Cable or the 3E-4594 Electrical Cable. For the engine harness, use the 6V-2744 Wire. The cable must be resistant to fuel and oil. The cable must have a temperature range of -40°C (-40°F) to plus 125°C (257°F).	
J1939 Data Link cable	16 or 18	Part number 153-2707 is available for lengths of up to 200ft. The cable has a temperature range of -40°C (-40°F) to plus 125°C (257°F). For longer runs, select a cable that meets SAE J1939-11 requirements.	Deutsch DT type of connectors are recommended. If Spring Spade or Ring Terminals are used, the connection between the terminals and the wire should be crimped and soldered.
Engine Solenoids (Air Shutoff)	14	Stranded wire normally used on engine harnesses. The cable must be resistant to fuel and oil. The cable must have a temperature range of -40°C (-40°F) to plus 125°C (257°F).	The leads of the cable should have Spring Spade Terminals or Ring Terminals. The Connection between the wire and the terminal should be crimped and soldered.
Power			
RS-485 Annunciator	14 or 16	Shielded twisted triad cable is recommended. Stranded wire normally used on engine harnesses. The cable must be resistant to fuel and oil. The cable must have a temperature range of -40°C (-40°F) to plus 125°C (257°F).	Deutsch DT type of connectors are recommended.

<sup>(1)</sup> The number of connections must be kept to a minimum.

**Table 2: Wiring Requirements**

### 3.11 SHIELDED AND COMMUNICATION WIRING

Shielded twisted pair cable is required for the magnetic speed sensor. CAN cable is required for Primary and Accessory CAN Data Links. This cable is used for maximum protection against inductive noise, electromagnetic interference, and radio frequency interference. The shield greatly reduces the amplitude of any unwanted voltages on the signal wire. The shields should not be connected to the sheet metal. If the shields are connected to sheet metal, the connections are susceptible to loose bolts, corrosion, etc. The faulty connections increase the resistance of the shield. Faulty connections also reduce the effectiveness of the shield.

When the cable terminates at junction boxes, the shields must be connected to each other in order to maintain a continuous path. A continuous path must be maintained in the shield wire for sensors, whenever possible. Wire exposed beyond the shield should be as short as possible. The shield must be connected to battery negative as close to the controller as possible. Shields should be drained at one point only. When possible, this should be done at, or close to, the EMCP 4.

To avoid electromagnetic interference, do not run shielded signal wires near other wires carrying large currents. In installations with unavoidable risk of electromagnetic interference (EMI), shielded wire run in conduit, extra shielding, or other precautions may be necessary.

## 4 INITIAL OPERATION AND USER ORIENTATION

### 4.1 TYPES OF EMCP 4 EVENTS

The EMCP 4 has two lamps to annunciate events. The amber lamp indicates warning-type events, while the red lamp indicates shutdown-type events. The lamps flash when new events arrive, and remain flashing (often accompanied by an audible horn) until acknowledged by pressing the acknowledge button locally or remotely. Shutdown-type events do not clear until the user fixes the condition(s) that caused the shut down and “resets” the events. The EMCP 4 supports a very large number of events, and most can be configured based on application needs. For information on viewing, resetting, and configuring events, see Chapter 5.

**Note:** The EMCP 4 will annunciate and display events from other modules, even if these events are not generated by the EMCP 4. These events are not logged in the EMCP itself, but are viewable from the individual module log located in the EMCP 4.

### 4.2 USING THE CAT SERVICE TOOL

Many of the features of the EMCP 4 system can be accessed via the Cat Service Tool. These features include viewing status data, monitoring optional modules, viewing and resetting events, and configuring setpoints.

**Note:** A minimum of the Cat Service Tool version 2010C is required to communicate properly with the EMCP 4. If an earlier version is used, the EMCP 4 will be grayed out.

Throughout this document, instructions for accessing a feature both via the EMCP 4 display and via the Cat Service Tool will be given. However, the Cat Service Tool also offers other unique features that are useful for site commissioning, ECM retrofitting, or troubleshooting, such as the ability to log data to a file or graph data in real-time. Such features are not in the scope of this document. For more information on the Cat Service Tool, refer to the Cat Service Tool documentation and training.

Figure 13 outlines the available EMCP 4 features that are available within the Electronic Technician software.

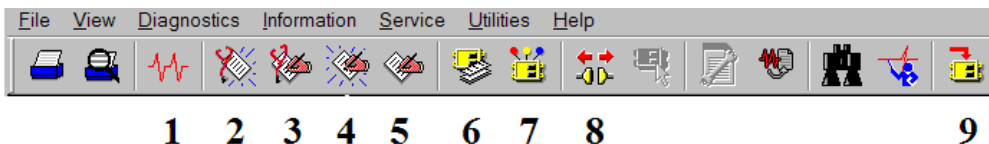

**Figure 13: Electronic Technician EMCP 4 Features**

1. Status Tool
2. Active Diagnostic Codes
3. Logged Diagnostic Codes
4. Active Event Codes
5. Logged Event Codes
6. ECM Summary
7. Configuration Tool
8. Connect/Disconnect
9. Winflash

When in the Status tool, buttons to Active Codes and Events are provided at the bottom of the screen.

**CONNECTING TO THE EMCP 4 TO CONFIGURE SETPOINTS**

In order to use the Cat Service Tool with the EMCP and configure setpoints, do the following:

1. Connect the Service Tool to the PC and configure the port settings as appropriate.
2. Ensure the Service Tool is connected to the Primary Data Link (CAN 1).
3. Start the Electronic Technician software.



4. The software will search the data links.

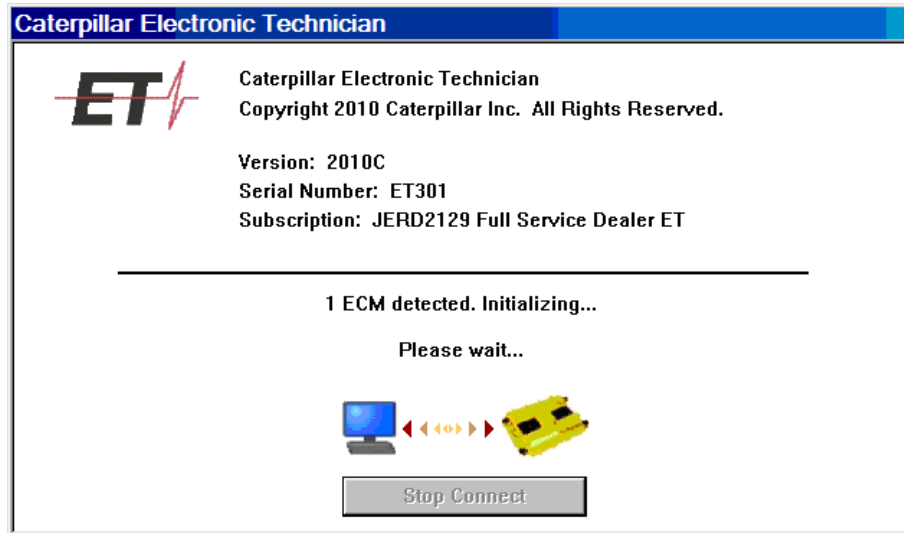

5. When the software finds the EMCP and connects to it, The ECM Summary screen will appear.

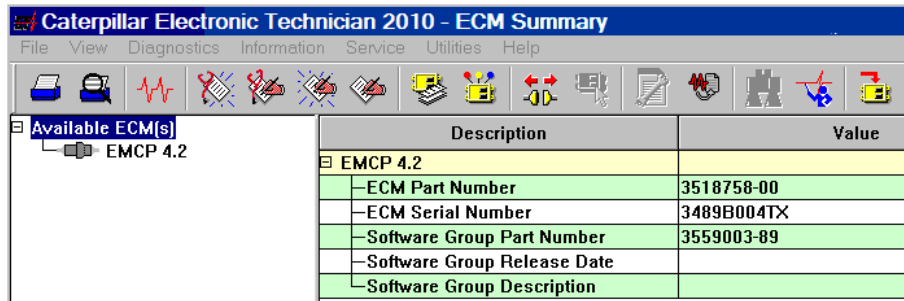

Description	Value
EMCP 4.2	
-ECM Part Number	3518758-00
-ECM Serial Number	3489B004TX
-Software Group Part Number	3559003-89
-Software Group Release Date	
-Software Group Description	

6. To view configurable parameters within the EMCP 4, press the Configuration button.

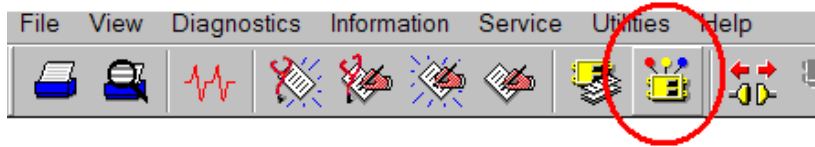

7. The parameter groups will appear.

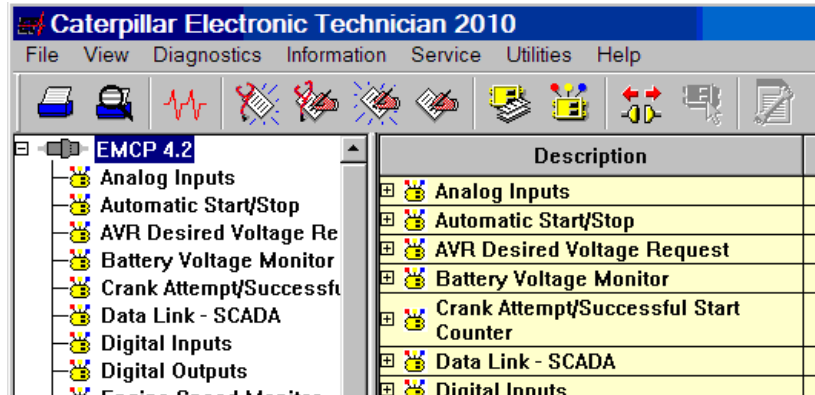

8. Selecting a group in the left pane will show all the parameters within that group in the right pane.

### 4.3 VIEWING SYSTEM PARAMETERS





Many generator and engine parameters are viewable in real time from both the Cat Service Tool, and the EMCP 4 display.

#### FROM THE CAT SERVICE TOOL

Parameters are accessed by selecting Information > Status from the menu, or by clicking on the **STATUS TOOL**  icon in the toolbar. Refer to the Cat Service Tool help from the Help > Contents menu for more information on the Status Tool.

#### FROM THE EMCP 4 DISPLAY

Parameters are accessed (irrespective of the current screen position) by pressing the **AC**

**OVERVIEW** , **ENGINE OVERVIEW** , or **Main Menu**  buttons located below the screen. Detailed screens provide even more information by pressing the **SCROLL DOWN**  button from each of the overview screens. For a description of the front view and navigation keys, refer to Appendix B.

The EMCP 4 parameters are organized with different levels of users in mind. These levels are as follows: View, Control, and Configure. Some of the parameters are accessible from multiple paths. For a complete menu structure, refer to Appendix A.

**SUPPORTED PARAMETERS**

Different versions of the EMCP 4 support different numbers of parameters. EMCP 4.2 supports multiple parameters not supported on the EMCP 4.1. Some parameters are only available in certain configurations, for example, electronic engine ECMs provide more engine data than what is available from mechanical engines. The sections below list all of the parameters available, and on which level of EMCP 4 they may be available.

Parameters are displayed with units, some of which are configurable. For changing units or setting other user preferences see Chapter 4.4, Viewing and Adjusting Preferences.

Parameters that are not available to the EMCP 4 are shown as \*\*\*\* (four asterisks). This may indicate an incorrect software configuration, a wiring problem, or a problem with the sensor.

**ENGINE OVERVIEW**

The Engine Overview screens display various engine parameters. The following parameters are displayed on the Engine Overview screens:

**ENGINE OVERVIEW SCREEN**

- Engine Oil Pressure
- Engine Coolant Temperature
- Battery Voltage, as measured at the connector entering the EMCP 4
- Engine Speed
- Engine Operating Hours
- Engine Operating State (Initialization, Pre-Crank, Starting, Running, Pre-Cooldown, Cooldown, Stopping, Stopped, Idling; many states are transient and only briefly active, and some states may not occur in some configurations)

34 Psi	188°F	24.8 V
1800 rPm		12.3 hrs
STOPPED		

**ENGINE SCREEN 1**

- Engine Oil Pressure
- Engine Coolant Temperature
- Engine Speed

OIL PRESSURE	34 Psi
COOLANT TEMP	188 °F
ENGINE SPEED	1800 rPm

**ENGINE SCREEN 2**

- Battery Voltage, as measured at the connector entering the EMCP 4
- Engine Hours

BATT VOLTAGE	24.8 V
ENGINE HRS	12.3

**ENGINE SCREEN 3 (EMCP 4.2 ONLY)**

- Engine Hours remaining until Service Maintenance Interval expires, or
- Calendar Days remaining until Service Maintenance Interval expires

SERV:	489 HOURS
OR	164 DAYS

**ENGINE SCREEN 4**

- Total engine Cranks since last reset (a crank is defined as the number of times the starter motor switches on)
- Total engine Starts since last reset (a start is defined as the number of times the engine transitions from below the Crank Terminate speed setpoint to above it)

TOTAL CRANKS	132
TOTAL STARTS	110

**ENGINE SCREEN 5 (EMCP 4.2 ONLY)**

- Cylinder #X Temperature (if temperature module is installed)

CYLINDER 01	254 °F
CYLINDER 02	255 °F
CYLINDER 03	254 °F

Press the **DOWN**  arrow to view the remaining cylinder temperatures.

**ENGINE SCREEN 6 (EMCP 4.2 ONLY)**

(if temperature module is installed)

- Temperature
- L Exhaust Man
- R Exhaust Man
- Intake Man
- Exhaust Temp
- Turbo 1 Comp In
- Turbo 2 Comp In
- Turbo 3 Comp In
- Turbo 4 Comp In
- Turbine 1 In
- Turbine 1 Out
- Turbine 2 In
- Turbine 2 Out
- Turbine 3 In
- Turbine 3 Out
- Turbine 4 In
- Turbine 4 Out

LEFT EXH MAN	258°C
RIGHT EXH MAN	256°C
EXHAUST TEMP	301°C

Press the **DOWN**  arrow to view the remaining temperatures.

**ENGINE SCREEN 7 (EMCP 4.2 ONLY)**

- Engine Oil Temperature
- Engine Fuel Temperature

ENG OIL TEMP	168°C
ENG FUEL TEMP	157°C

**ENGINE SCREEN 8 (EMCP 4.2 ONLY)**

- Engine Fuel Pressure
- Engine Crankcase Pressure
- Boost Pressure

ENG FUEL PRES	34kPA
ENG CRANK PRES	98kPA
BOOST PRES	24kPA

**ENGINE SCREEN 9 (EMCP 4.2 ONLY)**

- Oil Filter Differential Pressure
- Fuel Filter Differential Pressure

OIL FLTR DIF PRES 7kPA  
 FUEL FLTR DIF PRES 8kPA

**ENGINE SCREEN 10 (EMCP 4.2 ONLY)**

- Air Filter Differential Pressure

AIR FLTR DIF PRES 16kPA

**ENGINE SCREEN 11 (EMCP 4.2 ONLY)**

- Total Fuel Consumption
- Instantaneous Fuel Consumption Rate

TOTAL FUEL USE 134gal  
 INST FUEL RATE 44gph

**ENGINE SCREEN 12**

- SCR Tank Level Status

SCR TANK  
 LEVEL STATUS  
 94%

**ENGINE SCREEN 13**

- SCR Tank Temperature

SCR TANK  
 TEMPERATURE  
 102°C

**ENGINE SCREEN 14**

- SCR Air Assist Pressure

SCR AIR ASSIST  
 PRESSURE  
 18kPA

**ENGINE SCREEN 15**

- SCR Dosing Manifold Temperature

SCR DOSING MANIFOLD  
 TEMPERATURE  
 85°C

**ENGINE SCREEN 16**

- Catalyst Temperature

CATALYST  
 TEMPERATURE  
 118°C

**ENGINE SCREEN 17**

- SCR Exhaust Gas Differential Pressure

SCR EXHAUST GAS  
 DIFFERENTIAL PRESSURE  
 4kPA

## AC OVERVIEW

The AC Overview screens display various generator parameters. The following parameters are displayed on the AC Overview screens:

### AC OVERVIEW SCREEN

- Average Line-Line AC Voltage
- Average Current
- AC Frequency
- Power Factor (EMCP 4.2 Only)
- Power Factor Lead/Lag status (EMCP 4.2 Only)
- Total Generator Real Power – kW (EMCP 4.2 Only)
- Percent Real Power as a percentage of Generator Rated Power (EMCP 4.2 Only)

AVG:	480 V L-L	586 A
	60.0 Hz	0.87 LAGGING
TOTAL kW	404	67%

### GENERATOR SCREEN 1

- Line-Line Voltages: A-B, B-C, C-A
- Phase Currents: A, B, C
- AC Frequency

L-L V	479	480	480
A	587	586	586
60.0 Hz			

### GENERATOR SCREEN 2

- Line-Neutral Voltages: A-B, B-C, C-A
- Phase Currents: A, B, C
- AC Frequency

L-N V	277	278	277
A	587	586	586
60.0 Hz			

### GENERATOR SCREEN 3 (EMCP 4.2 ONLY)

- Total Generator Real Power – kW
- Total Generator Apparent Power – kVA
- Total Generator Reactive Power – kVAr

kW	404	406	404
kVA	427	426	425
kVAr	135	134	135

### GENERATOR SCREEN 4 (EMCP 4.2 ONLY)

- Total Generator Real Power – kW
- Total Generator Apparent Power – kVA
- Power Factor

kW	404	406	404
kVA	427	426	425
P.f.	0.87	0.86	0.87

### GENERATOR SCREEN 5 (EMCP 4.2 ONLY)

- Total Generator Real Power – kW
- Total Generator Apparent Power – kVA
- Total Generator Reactive Power – kVAr

TOTAL kW	404	67%
TOTAL kVA	426	67%
TOTAL kVAr	134	67%

### GENERATOR SCREEN 6 (EMCP 4.2 ONLY)

- Generator Real Energy produced since last meter reset
- Generator Reactive Energy produced since last meter reset

kWh	5629
kVArh	1602

**GENERATOR SCREEN 7**

- Average Line-Line AC Voltage
- Average Line-Neutral AC Voltage
- Power Factor (EMCP 4.2 Only)
- Power Factor Lead/Lag status (EMCP 4.2 Only)

AVERAGE L-L	480 V
AVERAGE L-N	277 V
P.f.	0.87 LAGGING

**GENERATOR SCREEN 8 (EMCP 4.2 ONLY)**

- Rear Bearing Temperature (if temperature module is installed)
- Front Bearing Temperature (if temperature module is installed)

BEARING TEMPERATURES	
REAR	122° F
FRONT	110° F

**GENERATOR SCREEN 9 (EMCP 4.2 ONLY)**

- Generator Phase A Winding Temperature (if temperature module is installed)
- Generator Phase B Winding Temperature (if temperature module is installed)
- Generator Phase C Winding Temperature (if temperature module is installed)

WINDING TEMPERATURES		
A	B	C
87°F	87°F	86°F

**GENERATOR SCREEN 10 (EMCP 4.2 ONLY)**

- Generator Excitation Field Voltage
- Generator Excitation Field Current

GEN EXCIT VOLTS	63.2V
GEN EXCIT CURRENT	9.8A

**4.4 VIEWING AND ADJUSTING PREFERENCES**

The EMCP 4 display can be used for monitoring the generator status, viewing and resetting events, and configuring setpoints. There are several preferences to alter how you view the data on the display. These include: display contrast, units used to display pressure, units used to display temperature, units used to display volume (EMCP 4.2 only), and displayed language (to select between the customer language and Technician English).

**Note:** These preferences do not affect operation of the EMCP 4 or the data as viewed in the Cat Service Tool. They only affect how the text and data is converted and displayed on the EMCP 4 display.

## SETTING THE PREFERENCES USING THE EMCP 4 DISPLAY

On the EMCP 4 display, the Preferences menu is located at the bottom of the Main Menu.

Scroll **DOWN**  to the desired Preference.

Press the **OK KEY** .

Use the Arrow keys to adjust the Preference as described below.

For any preference, press the **OK KEY**  to

accept the change (or **ESCAPE KEY**  to reject the change) and return to the Preferences menu.



MAIN MENU  
SOFTWARE INFO  
PREFERENCES



PREFERENCES  
CONTRAST  
PRESSURES



CONTRAST



PRESSURE







kPa Psi bar

**PREFERENCES**







- CONTRAST** This determines the darkness of the pixels on the display. A minimum contrast setting (reached by pressing and holding the down or left arrow) effectively blanks the screen, and a maximum contrast setting (reached by pressing and holding the up or right arrow) effectively darkens the entire screen. To change the contrast if the screen is unreadable due to a misconfiguration or ambient conditions, see **CHANGING THE EMCP 4 CONTRAST WHEN THE DISPLAY IS UNREADABLE**.
- PRESSURE** This allows pressure parameters (such as Engine Oil Pressure) and setpoints (such as Low Engine Oil Pressure Event Threshold) to be shown in either kPa, psi, or bar. Select the desired unit with the up or down arrows, or the Function keys.
- TEMPERATURE** This allows temperature parameters (such as Engine Coolant Temperature) and setpoints (such as High Engine Coolant Temperature Event Threshold) to be shown in either Celsius (Centigrade) or degrees Fahrenheit. Select the desired unit with the up or down arrows.
- VOLUME**  
(EMCP 4.2 only) This allows volume parameters (such as Fuel Volume) to be shown in Liters, Imperial Gallons, or US Gallons. Select the desired unit with the up or down arrows.
- LAMP TEST** When this selection is highlighted, pressing and holding the **OK KEY**  will darken all pixels on the screen and illuminate all LED's on the face of the controller.
- LANGUAGE** This allows the display to be switched between Technician English (always listed first) and the customer language (always listed second, and written in the font of the customer language). Select the desired language with the up or down arrows. To change the language to Technician English, regardless of the current screen, and without needing to read the text, see **CHANGING THE EMCP 4 DISPLAY TO TECHNICIAN ENGLISH**.

The **LANGUAGE** setting has been conveniently located at the bottom of the Preferences menu, which is at the bottom of the Main Menu.

**CHANGING THE EMCP 4 CONTRAST WHEN THE DISPLAY IS UNREADABLE**

1. Press the **MAIN MENU**  key
2. Scroll **DOWN**  until scrolling stops
3. Press the **OK KEY**  (this will take you into the Preferences Menu)
4. Press the **OK KEY**  again (this will take you into the Contrast selection)
5. Press and hold either **LEFT ARROW**  or **RIGHT ARROW**  until the text and graphics become visible
6. Press the **OK KEY**  to accept the adjustment







**CHANGING THE EMCP 4 DISPLAY TO TECHNICIAN ENGLISH**

1. Press the **MAIN MENU**  key
2. Scroll **DOWN**  until the scrolling stops
3. Press the **OK KEY**  (this will take you into the Preferences Menu)
4. Press the **DOWN ARROW**  key until scrolling stops
5. Press the **OK KEY**  (this will take you into the Language selection)
6. Press the **UP ARROW**  key until the scrolling stops
7. Press the **OK KEY**  to select **TECHNICIAN ENGLISH**

The EMCP 4 language setting is changed back to **TECHNICIAN ENGLISH**.

Similar steps can be followed by a customer who is unfamiliar with English, to change the language setting back to their primary language:











**CHANGING THE EMCP 4 DISPLAY TO THE PRIMARY LANGUAGE**

1. Press the **MAIN MENU**  key
2. Scroll **DOWN**  until the scrolling stops
3. Press the **OK KEY**  (this will take you into the Preferences Menu)
4. Press the **DOWN ARROW**  until the scrolling stops
5. Press the **OK KEY**  (this will take you into the language selection)
6. Press the **DOWN**  arrow to select the customer language
7. Press the **OK KEY**  to change to the customer language

The EMCP 4 language setting is changed back to the customer language.

**SETTING THE PREFERENCES USING THE SERVICE TOOL**

Only the preferences for units can be configured using the Cat Service Tool. They are located in the Configuration Tool. Select Display Preferences from the left panel.

<ul style="list-style-type: none"> <li> Electronic Control Module Reduced Pow</li> <li> Relay Outputs</li> <li> Remote Callback</li> <li> Service Maintenance Interval</li> <li> Spare Analog Input</li> <li> Programmable Trip Point Function</li> <li> Transfer Switch</li> <li> Utility Breaker Control</li> <li> Configuration Data</li> <li> Display Preferences</li> </ul>	<table border="1"> <thead> <tr> <th>Description</th> <th>Value</th> </tr> </thead> <tbody> <tr> <td>Display Pressure Units Configuration</td> <td>kPa</td> </tr> <tr> <td>Display Temperature Units Configuration</td> <td>Degrees Centigrade (Celsius)</td> </tr> <tr> <td>Display Volume Units Configuration</td> <td>Imperial gallons</td> </tr> </tbody> </table>	Description	Value	Display Pressure Units Configuration	kPa	Display Temperature Units Configuration	Degrees Centigrade (Celsius)	Display Volume Units Configuration	Imperial gallons
Description	Value								
Display Pressure Units Configuration	kPa								
Display Temperature Units Configuration	Degrees Centigrade (Celsius)								
Display Volume Units Configuration	Imperial gallons								
<div style="display: flex; justify-content: flex-end; gap: 20px;"> <span>Change</span> <span>Expand All</span> </div>									

**Figure 14: Display Preferences**

The display units can be changed the same way other setpoints are changed with the Service Tool.

- PRESSURE** This allows pressure parameters (such as Engine Oil Pressure) and setpoints (such as Low Engine Oil Pressure Event Threshold) to be shown in either kPa, psi, or bar.
- TEMPERATURE** This allows temperature parameters (such as Engine Coolant Temperature) and setpoints (such High Engine Coolant Temperature Event Threshold) to be shown in either Celsius (Centigrade) or degrees Fahrenheit.
- VOLUME** This allows volume parameters (such as Fuel Volume) to be shown in either Liters, Imperial Gallons, or US Gallons.  
(EMCP 4.2 ONLY)

#### 4.5 CONFIGURING TIME/DATE (EMCP 4.2 ONLY)

The EMCP 4.2 has an internal Real Time clock that is used for time-stamping events and Programmable Cycle Timer (Chapter 13). The timestamps for the last date and time an event has occurred and the first date and time the event has occurred are viewed by selecting a module in the Event Log and pressing the OK key, followed by the **DOWN**

**ARROW**  key. See Figure 15.

SPN 175	FMI 15	SPN 175	FMI 15
LAST HRS	33.6	FIRST HRS	33.6
01/01/10	11:23:27	28/02/10	16:21:13

**Figure 15: Event Details Screens**

#### CHANGING THE TIME / DATE

The EMCP 4.2 clock allows the time/date to be modified. Changing the time/date will change the timestamp on all future events, but not for existing events. (For example, an event that has occurred previously will still show the same FIRST time/date, but if it occurs again after the time/date has been adjusted, the LAST time/date will reflect the change.)

This procedure must be performed on the EMCP 4 display; it cannot be done using the Cat Service Tool. In order to update time/date, **LEVEL 1 ACCESS** is required. Refer to Chapter 6.

Security for information on obtaining **LEVEL 1 ACCESS**.

To change the time/date, do the following:

At **MAIN MENU** scroll **DOWN**  to **CONFIGURE**.

Press the **OK KEY** .



Scroll **DOWN**  to **TIME/DATE**.

Press the **OK KEY** .



To begin editing the time, press the **OK KEY**  while the current time is selected.

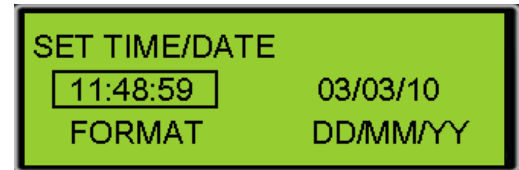

Press the **OK KEY**  again to enter the editor.



Select a digit using the **LEFT ARROW**  or **RIGHT ARROW** .

To change the selected digit use the **UP ARROW**  or **DOWN ARROW** .

To accept changes, press the **OK KEY** . To reject changes, press the **ESCAPE KEY** .

**To CHANGE THE DATE FROM THIS POINT**

Press the **ESCAPE KEY**  again to return to the **SET TIME/DATE** screen.

Press the **RIGHT ARROW**  key to put the box around the date.

Press the **OK KEY**  again to enter the editor.

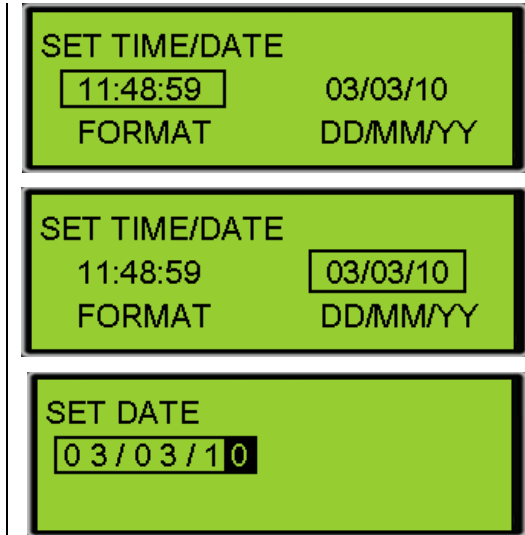

Select a digit using the **LEFT ARROW**  or **RIGHT ARROW** .

To change the selected digit use the **UP ARROW**  or **DOWN ARROW** .

To accept changes, press the **OK KEY** . To reject changes, press the **ESCAPE KEY** .

**CHANGING DATE FORMAT**

The data format can be set to either display in the form Month/Day/Year or the form Day/Month/Year. This procedure must be performed on the EMCP 4.2 display; it cannot be done using the Cat Service Tool.

**Note:** This preference does not affect operation of the EMCP 4 or the data as viewed in the Cat Service Tool. It only affects how the date is displayed on the EMCP 4 display and the format of the event time stamps.

To change the date format, do the following:

At **MAIN MENU** scroll **DOWN**  to **CONFIGURE**.

Press the **OK KEY** .

**SCROLL DOWN**  to **TIME/DATE**.

Press the **OK KEY** .

To begin editing the date, press the **OK KEY**  while the current date is selected.

Select the format using the

**LEFT ARROW**  or **RIGHT ARROW** , then press

the **OK KEY**  to accept, or the **ESCAPE KEY**

 to reject, the change.

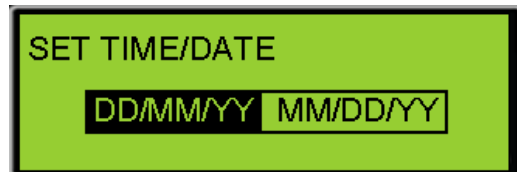
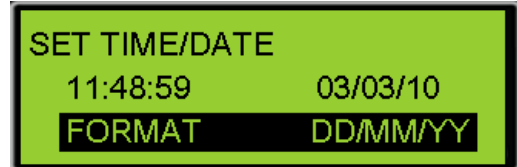

#### 4.6 ADJUSTING GENERATOR SET PARAMETERS

On many gensets, the engine speed, generator output voltage, and idle/rated status can be adjusted from the display of the EMCP 4. This ability is dependent upon the engine interface strategy and input/output configuration.

##### GENERATOR OUTPUT VOLTAGE

If the genset is equipped with a Cat Digital Voltage Regulator (Cat DVR), then the generator output voltage setpoint can be adjusted from the display of the EMCP 4, provided the CDVR is programmed to allow this control. In order for the **VOLTAGE ADJUST** to work via CAN, the **AVR VOLTAGE CONTROL DESIRED INPUT CONFIGURATION** setpoint in the CDVR must be programmed for **CAN INPUT**. If that setpoint is set to **SWITCH**, the **VOLTAGE CONTROL** from the EMCP 4 will **NOT WORK**.

##### ENGINE SPEED

If the genset is equipped with an ADEM A3 or A4 governor, then the engine speed setpoint can be adjusted from the display of the EMCP 4, provided the A3 is programmed to allow this control. In order for the **SPEED ADJUST** to work via CAN, the **DESIRED THROTTLE INPUT CONFIGURATION** setpoint in the A3 or A4 must be programmed for **CAN INPUT**. If that setpoint is set to **PWM**, the **SPEED CONTROL** from the EMCP 4 will **NOT WORK**.

## PROGRAMMING THE GENERATOR OUTPUT VOLTAGE AND ENGINE SPEED

From the **MAIN MENU** select **CONTROL**.

Press the **OK KEY** .

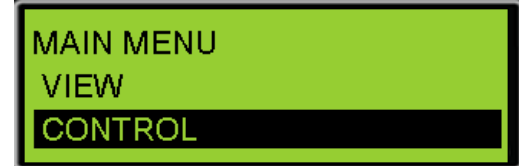

From the **CONTROL MENU**, select **VOLT/Hz CONTROL**.



Press the **OK KEY** .

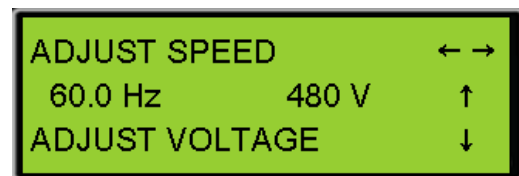

The speed and voltage adjust screen will be displayed.

To adjust the generator voltage from this screen:

Press the **DOWN ARROW KEY**  to **DECREASE** the generator voltage.

Press the **UP ARROW KEY**  to **INCREASE** the generator voltage.

To adjust the engine speed from this screen:

Press the **LEFT ARROW KEY**  to **DECREASE** the engine speed.

Press the **RIGHT ARROW KEY**  to **INCREASE** the engine speed.

The EMCP 4 will broadcast a desired engine speed bias based on the adjustment that is made. When the engine speed is adjusted, then that value will remain until either it is adjusted again or until the control is power-cycled. Unlike the setpoints or preferences

(i.e. contrast), any changes to this screen take effect immediately. The **OK KEY** 

and **ESCAPE KEY**  do not serve to accept or cancel changes.

### IDLE/RATED

The EMCP 4.1 and EMCP 4.2 both have the ability to be placed into Idle mode via the display, a Discrete Input, or through the SCADA Data Link. With some genset systems, the ADEM governor may also send the EMCP into Idle mode when the ADEM is operating in Idle mode. Idle mode will disable Under Speed, Under Voltage, and Under Frequency protections in the EMCP 4.

**Note:** The Engine Forced Idle Feature Enable Status parameter must be set to “Enabled” within Cat ET prior to seeing this menu option on the display. This setpoint is under the Automatic Start/Stop submenu in Cat ET.

When the EMCP 4 is placed in Idle mode, a programmable output may be programmed and wired to signal that it is operating in Idle. In some wiring configurations, the EMCP will also send a signal via the Primary CAN Data Link to the ADEM.

The engine speed can be toggled between **LOW IDLE** and **RATED SPEED** from the display of the control as follows:

From the **MAIN MENU** select **CONTROL**.

Press the **OK KEY** 

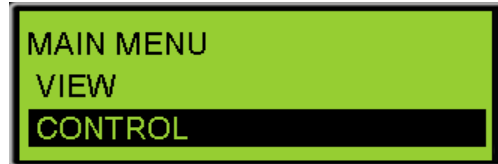

From the **CONTROL MENU** select **IDLE/RATED**.

Press the **OK KEY** 



The **IDLE/RATED** screen will be displayed and the current state will be shown.

Press the **OK KEY** 

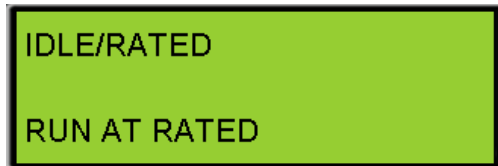

Press the **UP ARROW**  or **DOWN ARROW**  to change the state.

Press the **OK KEY** 



### ENGINE SENSOR VERSUS DATA LINK

The Engine Oil Pressure and Engine Coolant Temperature setpoints need special care when programming. These can be configured as either SENSOR or DATA LINK.



When SENSOR is configured, the physical sensor is connected directly to the EMCP 4. In this configuration, Analog Inputs are configured with the desired setpoints for the rated speed warnings and shutdowns. The idle setpoints are still configured under the Engine Oil Pressure Monitor.

When DATA LINK is configured, the physical sensors are connected to the engine ECM. The engine ECM is configured with setpoints to protect the engine. Sensor values may also be communicated to the EMCP over the data link. The EMCP allows for redundant setpoints to be assigned based on this information seen from the engine.

**TO CONFIGURE THE CONTROLLER AS SENSOR OR DATA LINK USING THE DISPLAY:**

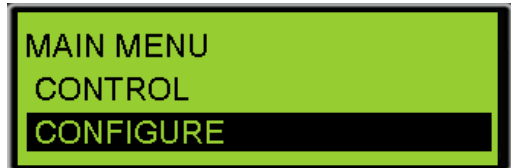
At MAIN MENU scroll DOWN  to CONFIGURE.  
 Press the OK KEY .



SCROLL DOWN  to ALL SETPOINTS.  
 Press the OK KEY .



SCROLL DOWN  to ENG MONITOR/PROTECT.  
 Press the OK KEY .







SCROLL DOWN  to ENG COOL TEMP MON OR ENG OIL PRES MON.  
 Press the OK KEY .

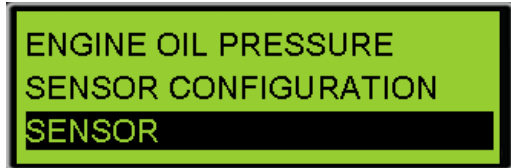

**Note:** Level 3 password is required.

Press the OK KEY .



To change the selection use the UP ARROW   
 or DOWN ARROW   
 Press the OK KEY .

**TO CONFIGURE THE CONTROLLER AS SENSOR OR DATA LINK USING CAT ET:**

1. Connect to the EMCP 4 using the Cat Service Tool as stated in Chapter 4.2.
2. Select Automatic Start/Stop on the left.



3. Double click the Engine Coolant Temperature Sensor Configuration setpoint to change this value from the drop down menu. Click the OK button to program.

**Change Parameter Value** [?] [X]

Parameter Name: Engine Coolant Temperature Sensor Configuration

Current Value: Sensor

New Value: Data Link (selected)  
Data Link  
Sensor

Please select one of the listed values for this parameter.

[OK] [Cancel]

4. Double click the Engine Oil Pressure Sensor Configuration setpoint to change this value from the drop down menu. Click the OK button to program.

**Change Parameter Value** [?] [X]

Parameter Name: Engine Oil Pressure Sensor Configuration

Current Value: Sensor

New Value: Data Link (selected)  
Data Link  
Sensor

Please select one of the listed values for this parameter.

[OK] [Cancel]

## ENGINE OIL PRESSURE

The Engine Oil Pressure setpoints need special care when programming. The first step is to set the configuration as either SENSOR or DATA LINK.

When SENSOR is configured, the physical sensor is connected directly to the EMCP 4. In this configuration, Analog Input #1 (normally used for Oil Pressure Sensor) is configured with the desired setpoints for the rated speed Oil Pressure warnings and shutdowns. The idle speed step and idle oil pressure setpoints are still configured under the Engine Oil Pressure Monitor.

When DATA LINK is configured, the physical sensor is connected to the engine ECM. The engine ECM is configured with setpoints to protect the engine. Sensor values may also be communicated to the EMCP over the data link. The EMCP allows for redundant setpoints to be assigned based on this information seen from the engine.

**SENSOR CONFIGURATION**

In SENSOR configuration, Analog Input #1 contains the parameters for warnings and shutdowns for High and Low OIL PRESSURE. Security Level 3 is required to program Analog Input #1.

**TO CONFIGURE ANALOG INPUT #1 FOR ENGINE OIL PRESSURE:**

AT THE MAIN MENU, scroll down  to CONFIGURE.

Press the OK KEY 

SCROLL DOWN  to INPUTS & OUTPUTS.

Press the OK KEY 

SCROLL DOWN  to ANALOG INPUTS.

Press the OK KEY 

Alternately, access to THE INPUTS & OUTPUTS submenu is accessible from ALL SETPOINTS.

Select the ANALOG INPUT #1.

Press the OK KEY 

Press the OK KEY  to highlight the current configuration (DISABLED, RESISTIVE, OR VOLTAGE).

Scroll DOWN  to RESISTIVE .

Press the OK KEY 

Scroll DOWN  to DATA IDENTIFICATION

Press the OK KEY  to change the current DATA IDENTIFICATION.

Select the DATA IDENTIFICATION to ENG OIL PRES.

Press the OK KEY 



MAIN MENU  
CONTROL  
CONFIGURE



INPUTS & OUTPUTS  
DIGITAL INPUTS  
RELAY OUTPUTS



INPUTS & OUTPUTS  
DIGITAL OUTPUTS  
ANALOG INPUTS



ANALOG INPUTS  
ANALOG INPUT #1  
ANALOG INPUT #2



ANALOG INPUT #1  
USAGE TYPE:  
DISABLED



ANALOG INPUT #1  
USAGE TYPE:  
RESISTIVE



ANALOG INPUT #1  
DATA IDENTIFICATION:  
DATA LINK - SCADA



ANALOG INPUT #1  
DATA IDENTIFICATION:  
ENG OIL PRES

Scroll **DOWN**  to configure the remaining setpoints for Analog Input #1:

- Map Selection Number
- Low Warning Threshold
- Low Warning Delay
- Low Warning Event Response
- Low S/D Threshold
- Low S/D Delay
- Low S/D Event Response
- Isolated Supply Voltage

In addition to the setpoints for high and low Oil Pressure available in Analog Input #1, setpoints for LOW IDLE LOW OIL PRESSURE and STEP SPEED are also available in the ENG MONITOR/PROTECT menu.

**TO CONFIGURE THESE SETPOINTS:**

At **MAIN MENU** scroll **DOWN**  to **CONFIGURE**.

Press the **OK KEY** .



**SCROLL DOWN**  to **ALL SETPOINTS**.

Press the **OK KEY** .



**SCROLL DOWN**  to **ENG MONITOR/PROTECT**.

Press the **OK KEY** .



**SCROLL DOWN**  to **ENG OIL PRES MON**.

Press the **OK KEY** .



**Note:** Level 3 password is required.

Scroll **DOWN**  to configure the remaining setpoints for Engine Oil Pressure Monitor:

- Low Eng Oil Pressure Warning Threshold
- Low Idle Low Eng Oil Pres Warn Threshold
- Low Eng Oil Pressure Warning Delay Time
- Low Eng Oil Pressure Shutdown Threshold
- Low Idle Low Eng Oil Pres S/D Threshold
- Low Eng Oil Pressure Shutdown Delay Time
- Low Engine Oil Pressure Step Speed

**Note:** All DATA LINK OIL PRESSURE setpoints in this menu are inactive when in SENSOR configuration. The Low Idle setpoints are still active regardless of SENSOR or DATA LINK. They are labeled as DATA LINK to refer to the fact they are only active when the DATA LINK configuration is chosen.

### DATA LINK

The OIL PRESSURE setpoints when in the DATA LINK configuration are redundant to the primary protection provided by the engine ECM. If these protections are not programmed to match those in the ADEM and an event occurs, check the Event Logs to determine which module generated the event.

### ENGINE COOLANT TEMPERATURE

The Engine Coolant Temperature setpoints need special care when programming. The first step is to set the configuration as either SENSOR or DATA LINK.

When SENSOR is configured, the physical sensor is connected directly to the EMCP. In this configuration, Analog Input #2 (normally used for Coolant Temperature) is configured with the desired setpoints for Coolant Temperature warnings and shutdowns.

When DATA LINK is configured, the physical sensor is connected to the engine ECM. The engine ECM is configured with setpoints to protect the engine. Sensor values may also be communicated to the EMCP over the data link. The EMCP allows for redundant setpoints to be assigned based on this information seen from the engine.

### SENSOR CONFIGURATION

In SENSOR configuration, Analog Input #2 contains the configurations for alarms and shutdowns for High and Low COOLANT TEMPERATURE. Security Level 3 is required to program Analog Input #2.

### TO CONFIGURE ANALOG INPUT #2 FOR ENGINE COOLANT TEMPERATURE:

AT THE MAIN MENU, scroll down  to CONFIGURE

Press the OK KEY 

SCROLL DOWN  to INPUTS & OUTPUTS

Press the OK KEY 

SCROLL DOWN  to ANALOG INPUTS

Press the OK KEY 

Alternately, access to THE INPUTS & OUTPUTS submenu is accessible from ALL SETPOINTS.

Select the ANALOG INPUT #2

Press the OK KEY 



MAIN MENU  
CONTROL  
CONFIGURE



INPUTS & OUTPUTS  
DIGITAL INPUTS  
RELAY OUTPUTS



INPUTS & OUTPUTS  
DIGITAL OUTPUTS  
ANALOG INPUTS



ANALOG INPUTS  
ANALOG INPUT #1  
ANALOG INPUT #2

Press the **OK KEY**  to highlight the current configuration (**DISABLED, RESISTIVE, OR VOLTAGE**).

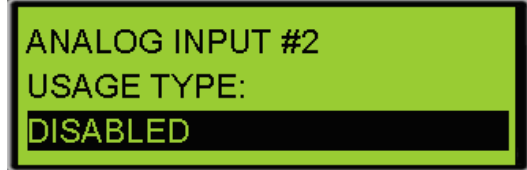

Scroll **DOWN**  to select the appropriate sensor



Press the **OK KEY** .

Scroll **DOWN**  to **DATA IDENTIFICATION**

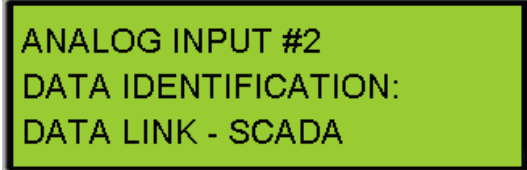

Press the **OK KEY**  to change the current **DATA IDENTIFICATION**.

Select the **ENG COOLANT TEMP**

Press the **OK KEY** .



Scroll **DOWN**  to configure the remaining setpoints for Analog Input #2:

- Map Selection Number
- Low Warning Threshold
- Low Warning Delay
- Low Warning Event Response
- Low S/D Threshold
- Low S/D Delay
- Low S/D Event Response
- Isolated Supply Voltage

**Note:** All COOLANT TEMP setpoints in the ENG MONITOR/PROTECT menu are inactive when in SENSOR configuration. They are labeled as DATA LINK to refer to the fact they are only active when the DATA LINK configuration is chosen.

**DATA LINK**

The COOLANT TEMPERATURE setpoints when in the DATA LINK configuration are redundant to the primary protection provided by the engine ECM. If these protections are not programmed to match those in the ADEM and an event occurs, check the Event Logs to determine which module generated the event.

## 4.7 STARTING AND STOPPING THE GENERATOR SET

### STARTING THE ENGINE

Once the control is configured correctly, the control panel is powered up, and the generator set is ready to be operated, the generator set can be started. Refer to Figure 16, Stopping The Engine. There are several ways the generator set can be started from the control panel.

To **START** the engine:

1. In **MANUAL OPERATION**, press the **RUN KEY** 
- or
2. Activate a Digital Input programmed for ECS in Run
- or
3. Place the control in **AUTO** mode then,
4. The engine can be started **THREE DIFFERENT WAYS**:
  - a: Activate the **REMOTE START INPUT**
  - b: Activate a **REMOTE INITIATE** over the MODBUS data link (EMCP 4.2 only)
  - c: Configure a **PROGRAMMABLE CYCLE TIMER** (EMCP 4.2 only). See Chapter 13.

When the control panel initiates a start command on a diesel engine, the EMCP checks to make sure there are no **SHUTDOWN EVENTS** present (labeled **PRESENT**) or that there are no latched **SHUTDOWN EVENTS** (labeled **ACTIVE**).

If there are no shutdown events that are active or present, and after any pre-crank or start-aid activities have completed, the starter motor and fuel control will be activated. The EMCP 4 will activate the Digital or Relay Output programmed to activate the starter motor magnetic switch, and the Digital or Relay Output programmed to activate the fuel enable circuit.

On electronic engines with ADEM™ A3 or newer engine ECMs using Common Engine Interface, the start command and fuel enable signals may be sent from the EMCP 4 to the engine ECM via the PRIMARY CAN data link. After receiving the signals, the engine ECM will operate the fuel control relay and starter motor magnetic switch. Digital or Relay Outputs #1 and #2 are not needed on those engines and can be configured for other uses.

The Starter Motor Relay will remain active until the programmed **ENGINE CRANK TIME** has been reached, or until the engine speed has reached the programmed **CRANK TERMINATE SPEED** setpoint value.

**Note:** The EMCP 4 Crank setpoints number of cranks, crank duration, and crank terminate speed are not used on engines with the Common Engine Interface option or newer engine ECM. These values must be adjusted in the engine ECM.

**Caution:** To determine the exact starting sequence for your engine, consult your engine's Operation and Maintenance Manual.

**Note:** If a Digital Input is programmed for ECS in Auto, or Run, or Stop, and a maintained switch latches that input to make it active, the front panel buttons will not have any effect.

## EMCP 4 REMOTE START

The EMCP 4 has the ability to accept a remote start signal. If this signal is activated, the EMCP will send an Engine Start request to the engine controller. If the Remote Start signal is removed, the EMCP will send a Stop request signal to the engine controller. A momentary signal will not keep the engine running.

This signal should be wired into pin 55. This input will become active when pulled down to battery negative.

## STOPPING THE ENGINE

Once the engine is started, the engine can be stopped by pressing the **STOP KEY**  on the control panel, or activating a Digital Input programmed for ECS in Stop. If the control is in **AUTO**, the engine can also be stopped by **DEACTIVATING** all of the remote initiate commands. There are three possible sources for this command:

1. The **REMOTE START INPUT**
2. The **REMOTE START COMMAND** over the Modbus data link (EMCP 4.2 only).
3. The **PROGRAMMABLE CYCLE TIMER** (EMCP 4.2 only). See Chapter 13

Once the **STOP** command is issued, the control will go into **COOLDOWN MODE**. Cooldown mode will run for the duration of time that it is programmed in the **COOLDOWN DURATION** setpoint. If the cooldown time is set for zero minutes, the engine will stop immediately.

On engines with ADEM™ A4 or newer engine ECMs using Common Engine Interface, the cooldown timer in the EMCP 4 should be set to 0 (Zero) minutes because the cooldown time is controlled from the engine ECM (if this is not done, both cooldown timers will run in sequence). Also, the **ENGINE OPERATING STATE INPUT CONFIGURATION** parameter must be set to **CAN INPUT**.

The cooldown timer can be overridden by pressing and holding the **STOP KEY**  for approximately 5 seconds. The display will show a splash screen that will ask if you want to **BYPASS COOLDOWN?** or continue with the cooldown cycle.

If the **OK KEY**  is pressed from the splash screen, the cooldown timer will be bypassed.

If the **ESCAPE KEY**  is pressed from the splash screen, the cooldown cycle will continue until the programmed cooldown time has elapsed.

When the cooldown timer has elapsed or has been bypassed, the Discrete or Relay Output programmed for fuel injection will be disabled (by default, Relay Output #2 will deactivate, but this may be programmed differently). The **STOP** command will also be sent over the PRIMARY CAN data link for those engines that require it. The engine will come to a stop.

Any time, while the engine is **RUNNING**:

If the EMCP 4 detects a condition where an engine or generator parameter exceeds programmed event thresholds for a programmed amount of time, or another **SHUTDOWN EVENT** occurs, then the EMCP 4 will attempt to shut the engine down.

**Note:** Event behavior is determined by setpoints called EVENT RESPONSE CONFIGURATIONS. If a shutdown-type event's EVENT RESPONSE CONFIGURATION is disabled or not set to shutdown, it may not shut the engine down. Appropriate default values are pre-configured in the factory. Modify EVENT RESPONSE CONFIGURATIONS at your own risk! See Chapter 5.

**Note:** If a Digital Input is programmed for ECS in Auto, or Run, or Stop, and a maintaining switch latches that input to make it active, the front panel buttons will not have any effect.

Depending on how a specific EVENT RESPONSE CONFIGURATION is programmed, the EMCP 4 will either put the engine in **COOLDOWN**, followed by a shutdown (**SOFT SHUTDOWN**) or shut the engine down immediately (**HARD SHUTDOWN**). See Figure 16.

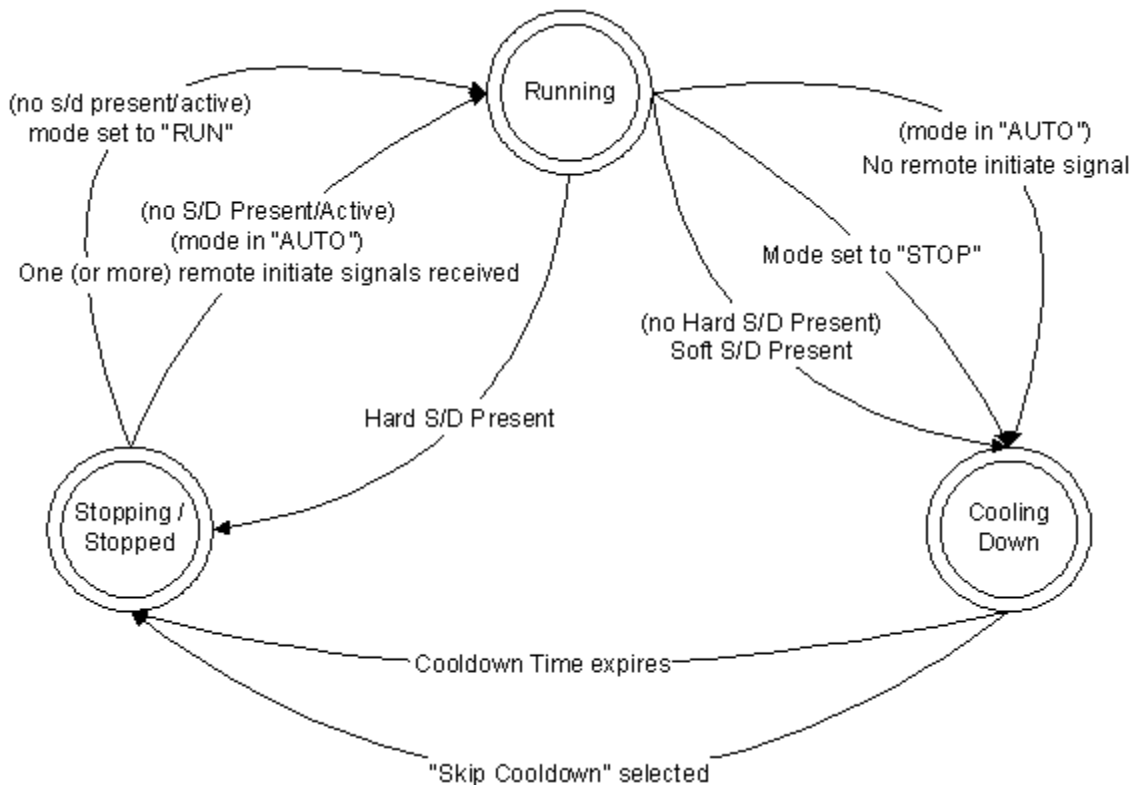

**Figure 16: Stopping the Engine**

### EMERGENCY STOP

The EMCP 4 Emergency Stop input is configurable as Active High, or Active Low. The active state may be viewed within the EMCP 4, but is only configurable within Cat ET.

**TO VIEW THE E-STOP ACTIVE STATE CONFIGURATION FROM THE DISPLAY, DO THE FOLLOWING:**

At **MAIN MENU** scroll **DOWN**  to **CONFIGURE**.

Press the **OK KEY** .



**SCROLL DOWN**  to **ALL SETPOINTS**.

Press the **OK KEY** .



**SCROLL DOWN**  to **CONTROL**.

Press the **OK KEY** .



**SCROLL DOWN**  to **AUTO START/STOP**.

Press the **OK KEY** .



**SCROLL DOWN**  to **EMERGENCY STOP INPUT ACTIVE STATE CONFIG**.



**TO CHANGE THE E-STOP ACTIVE STATE CONFIGURATION, DO THE FOLLOWING:**

1. Connect to the EMCP 4 using the Cat Service Tool as stated in Chapter 4.2.
2. Select Automatic Start/Stop on the left.

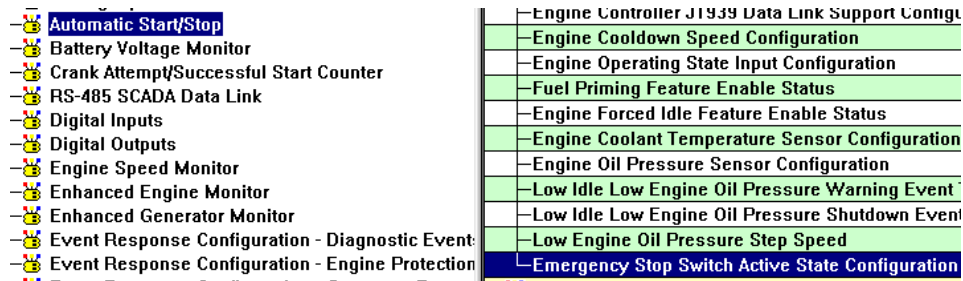

3. Double click Emergency Stop Switch Input Configuration on the right to select a new value.

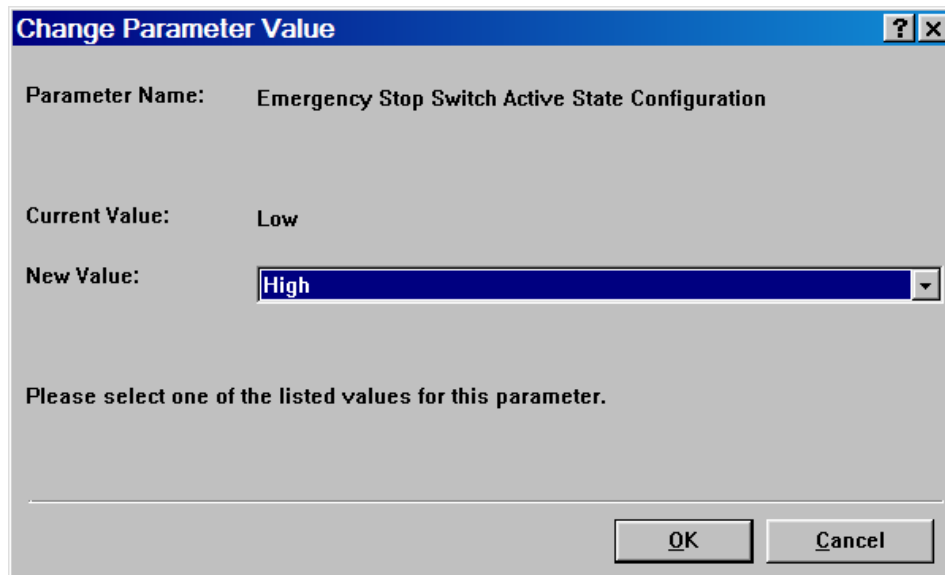
**EMCP 4 REMOTE STOP**

The EMCP 4 has the ability to accept a remote stop signal. For Common Engine Interface, if this signal is activated, the EMCP will send an Engine Stop request to the engine controller. If the Remote Stop signal is removed, and the EMCP is in Auto mode, the EMCP may send a Start request signal to the engine controller if other conditions are already met (a Digital Input programmed for Run, for example).

This signal should be wired to a Digital Input.

## 4.8 ENGINE SETPOINT VERIFICATION

The engine setpoint verification procedure verifies that the EMCP 4 operates correctly when a **LOW OIL PRESSURE** or **HIGH COOLANT TEMPERATURE** event occurs. The engine setpoint verification procedure also verifies that the EMCP 4 operates correctly when an **ENGINE OVERSPEED** event occurs.

On an **ENGINE OVERSPEED** event, the EMCP 4 will shut the engine down.

**LOW OIL PRESSURE** and **HIGH COOLANT TEMPERATURE** each have two events, **WARNING** and **SHUTDOWN**. The EMCP 4 will issue a **WARNING** whenever the warning threshold is reached and a **SHUTDOWN** whenever the shutdown threshold is reached. This verification procedure will modify configuration setpoints used in normal operation. The steps below outline how to perform the **LOW OIL PRESSURE SHUTDOWN** and **HIGH COOLANT TEMPERATURE SHUTDOWN PROCEDURE**. A similar process can be used for **LOW OIL PRESSURE WARNING** and **HIGH COOLANT TEMPERATURE WARNING**, along with **LOW IDLE LOW OIL PRESSURE**.

During this procedure

- Each configuration setpoint should be recorded prior to adjustment.
- Returned back to the original setting after the setpoint has been verified.

The following conditions are required before the **ENGINE SETPOINTS** are verified:

### REQUIRED CONDITIONS

- The setpoints must be correct for the engine application.
- No shutdown events should be present. If necessary, troubleshoot, correct, and reset any and all shutdown events.

### PROCEDURE FOR OVERSPEED VERIFICATION

**Note:** Adjustment of **ENGINE OVER SPEED SHUTDOWN THRESHOLD** setpoint from the display requires a level 3 password. For details on changing security levels refer to Chapter 6..

The Security Level only affects changing parameters from the EMCP 4. Changing parameters with the Cat Service Tool does not require passwords.

1. Start the engine and run the engine at rated speed.
2. Adjust the setpoint value for Engine Over Speed Shutdown Threshold to a value that is below the speed that the engine is running at. An Engine Overspeed Shutdown event will occur immediately after the setpoint is changed, and the engine will shut down.
3. View the event by going to the Genset Control event log. Reset the event. For more information about how to view and reset the event, refer to Chapter 5, Handling Events.
4. Return the setpoint value for Engine Over Speed Shutdown Threshold to the original value.

## PROCEDURE FOR LOW OIL PRESSURE VERIFICATION

**Note:** Low Oil Pressure Shutdown is disabled during start-up and while the engine is not running by the Fault Protection Timer (FPT). The fault protection timer starts timing when crank terminate RPM is reached during the starting sequence. The fault protection timer will then run for a programmed time which is determined by the Engine Start Fault Protection Activation Delay Time setpoint. Make sure the fault protection timer has elapsed before starting the Low Oil Pressure Verification.

1. Start the engine and run the engine at rated speed.
2. Determine whether the controller is set for SENSOR or DATA LINK, refer to Chapter 4.6.  
 If SENSOR is selected, perform steps 3-5 in the CONFIGURE→INPUTS & OUTPUTS→ANALOG INPUTS configuration for ANALOG INPUT#1 setpoints.  
 If DATA LINK is selected, perform steps 3-5 in the CONFIGURE→ALL SETPOINTS→ENG MONITOR/PROTECT→ENG OIL PRES MON setpoints.
3. Adjust the setpoint value for Low Engine Oil Pressure Shutdown Event Threshold to a value that is above the oil pressure that the engine is operating at. The shutdown event will occur after the programmable time delay (the Low Engine Oil Pressure Shutdown Delay Time setpoint).
4. View the event by going to the Genset Control event log. Reset the event. For more information about how to view and reset the event, refer to Chapter 5, Handling Events.
5. Return setpoint value for Low Engine Oil Pressure Shutdown Event Threshold to the original value.

## PROCEDURE FOR HIGH COOLANT TEMPERATURE VERIFICATION

**Note:** High Coolant Temperature shutdown is disabled during start-up and while the engine is not running by the Fault Protection Timer (FPT). The fault protection timer starts timing when the crank terminate RPM is reached during the starting sequence. The fault protection timer will then run for a programmed time (the Engine Start Fault Protection Activation Delay Time setpoint). Make sure the fault protection timer has elapsed before starting the High Coolant Temperature Verification.

1. Start the engine and run the engine at rated speed.
2. Determine whether the controller is set for SENSOR or DATA LINK, refer to Chapter 4.6.  
 If SENSOR is selected, perform steps 3-5 in the CONFIGURE→INPUTS & OUTPUTS→ANALOG INPUTS configuration for ANALOG INPUT#2 setpoints.  
 If DATA LINK is selected, perform steps 3-5 in the CONFIGURE→ALL SETPOINTS→ENG MONITOR/PROTECT→ENG COOL TEMP MON setpoints.

3. Adjust setpoint value for High Engine Coolant Temperature Shutdown Event Threshold to a value that is below the engine coolant temperature that the engine is operating at. The minimum value for this setpoint is 49°C (120°F), so you may have to run the engine for a few minutes to get the temperature above the minimum value. The shutdown event will occur after the programmable time delay (the High Engine Coolant Temperature Shutdown Event Notification Delay Time setpoint).
4. View the event by going to the Genset Control event log.
5. Reset the event. Refer to Handling Events for more information about how to view and reset the event.
6. Return setpoint value for High Engine Coolant Temperature Shutdown Event Threshold to the original value.

#### **4.9 ENGINE OPERATING HOURS**

One of the features of the EMCP 4 is the ability to maintain the **ENGINE OPERATING HOURS**, which is the cumulative amount of time that the engine has run above the Crank Terminate speed. This time is displayed on the Engine Overview screen, just below Battery Voltage.

##### **UPDATING ENGINE OPERATING HOURS**

For applications where a new EMCP 4 is fitted to a generator set that was previously in operation, the EMCP 4 allows the user to increment the engine hours to match the engine.

**Note:** Engine Hours can only be increased. They cannot be decreased.

This procedure must be performed on the EMCP 4 display; it cannot be done using the Cat Service Tool. In order to update engine hours, **LEVEL 3 ACCESS** is required. Refer to Chapter 6 Security.

**UPDATING ENGINE HOURS**

At **MAIN MENU SCROLL**

**SCROLL DOWN**  to **CONFIGURE**

Press the **OK KEY** 



Scroll **DOWN**  to **ENGINE OPERATING HOURS**

Press **OK KEY** 



(if pressing OK has no effect, then Level 3 access has not been obtained)

Current **ENGINE HOURS** are displayed.

Press the **OK KEY**  to change the hours.

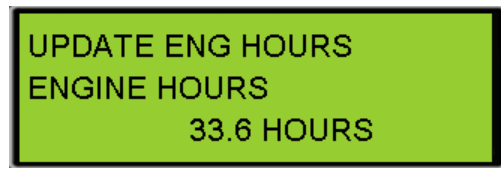

To edit the **ENGINE HOURS**, Select a digit using the

**LEFT ARROW**  or **RIGHT ARROW** 

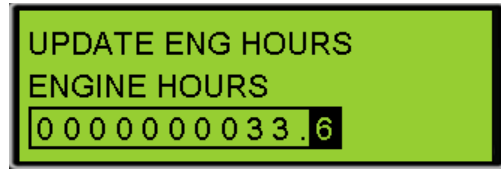

To change the selected digit use the **UP ARROW**

 or **DOWN ARROW** 

To accept changes, press the **OK KEY** . To reject changes, press the **ESCAPE KEY** .

Again, press the **OK KEY**  to confirm, or the

**ESCAPE KEY**  to reject the changes.



## 5 HANDLING EVENTS

The EMCP 4 shows previous and current events from both the EMCP and external modules. These events are organized into logs for each physical EMCP 4 module.

The logs include:

GENSET CONTROL	Events for the EMCP 4 GSC
ENGINE CONTROL	Events for a Primary CAN Data Link-compatible engine ECM
DIGITAL AVR	Events for the Cat Digital Voltage Regulator (Cat DVR)
THERMOCOUPLE	Events for the Thermocouple Module
EXTERNAL I/O	Events for the Discrete Input/Output (DIO) module
RTD MODULE	Events for the Resistive Temperature Device (RTD) module
SCR MODULE	Events for Engine Aftertreatment systems

The Genset Control Log stores events generated by the EMCP 4. Any other event is stored within the module that generated the event. Even if the EMCP annunciates an event, it does not mean that the EMCP logs that event. It may be within another module's log.

Each log is visible only if the module is connected to the appropriate data link, either the Primary data link or the Accessory data link, and is communicating with the EMCP 4.



The list of Event Logs can be viewed by pressing the Event Log hotkey **EVENT LOG** or via the View Submenu. Select the log you wish to view and press OK to view the events.

The EMCP 4 supports more than one instance of some of the above modules. (See Chapter 17, for the number of modules supported by each of the EMCP models). Those modules are uniquely identified with a number at the end of the log name.

The module number is software-configured, and is called the module's **ECU INSTANCE NUMBER**. The ECU Instance Number can be viewed and modified by the Cat Service Tool. See the appropriate sub section of Chapter 17, for the expansion module in question, to see how to program the Instance Number.

An event in the EMCP 4 Genset Control Log can be in one of three states; **PRESENT**, **ACTIVE**, or **INACTIVE**.

- PRESENT** This state is only applicable to the Genset Control Log. **PRESENT** means that the condition that caused the event is still present. The condition needs to be addressed before the event can be reset.
- Note:** This state only applies to Genset Control events. Other modules will not have Present in logs.
- ACTIVE** The event was previously in a “Present” state, but it is no longer present. It has been latched by the event system and needs to be reset before the engine can be restarted.
- Within the Genset Control Log, the condition that caused the event is still affecting the system, but may be reset. (See Chapter 5.3 through 5.6 on how to Reset Events). Warning type events automatically reset when the condition that caused the event is resolved and will never be Active.
- Within any log other than the Genset Control Log, the condition that caused the event is affecting the system. The event may, or may not, be resettable. If the Reset All command fails to reset the event, then this event is still occurring and must be resolved before the event can be reset.
- Note:** Many events go from Present to Active when the engine is shutdown and may reoccur once the engine starts running again. Further action may be required to resolve the issue.
- INACTIVE** The event has happened at some time in the past but is no longer affecting the system. Inactive events are stored for historical purposes only.

## 5.1 CONFIGURING EVENT RESPONSES FOR EMCP 4 GENERATED EVENTS

The category of event, as well as other behavior when an event occurs, can be configured via a group of EMCP 4 setpoints called **EVENT RESPONSE CONFIGURATIONS**. An example of an event response configuration is **LOW ENGINE LOW OIL PRESSURE WARNING EVENT RESPONSE CONFIGURATION**. This setpoint determines what actions the EMCP 4 takes when it receives an event.

**Note:** Event Response Configuration is only valid for the EMCP 4, not any other modules.

Each **EVENT RESPONSE CONFIGURATION** type setpoint can either be viewed or edited. By default, VIEW is highlighted. These setpoints can only be edited when the ECS is in the Stop mode.

The following is a list of all the possible options for an event response configuration:

- WARNING** Creates a Warning event in the event log and lights the amber LED. The engine will not shut down. A Warning event will reset by itself (i.e. it will go from the “Present” state to the “Inactive” state) as soon as the condition that caused it goes away.
- AUDIBLE ALERT** Determines whether this event will also trigger an audible horn. If so, the event activates any relays that are programmed for Horn Control (see Chapter 10 Relay Outputs or Chapter 10 Digital Outputs). If no relay is programmed for Horn Control, no action will be taken; the EMCP 4 does not have an internal horn. Audible Alert can only be programmed if either a Warning or Shutdown is also programmed.
- SOFT SHUTDOWN** Creates a Shutdown event in the event log, lights the red LED, and shuts the engine down after the cooldown period has expired (see Chapter 4.5: Starting and Stopping the Engine).
- HARD SHUTDOWN** Creates a Shutdown event in the event log, shuts the engine down immediately and lights the red LED.
- BREAKER #1 TRIP** Activates a Breaker #1 Trip, which can be programmed for a Relay Output or Digital Output for external use. Breaker #1 usually refers to the Generator circuit breaker.
- BREAKER #2 TRIP** Activates a Breaker #2 Trip, which can be programmed for a Digital Output or Relay Output for external use. Breaker #2 may refer to a second circuit breaker.
- FAULT PROTECTION TIMER ENABLED** Suppresses the event unless the engine is running and the Fault Protection Timer has expired (this prevents nuisance events during startup, or ones that are not relevant when the engine is stopped).
- ACTIVE ONLY** Creates an Active Only event in the event log. Active Only events are for informational purposes only. They typically do not light the Amber LED or behave like a Warning (although many events can be configured to do so). When the condition goes away, the event disappears from the event log.

**Note:** Not all options are available for all setpoints. For example, the Engine Low Oil Pressure Warning event cannot be configured as a shutdown, because there is a separate event (Engine Low Oil Pressure Shutdown) dedicated for that purpose. Likewise, events cannot be generated for any and all conditions. For example, a Low Engine Coolant Temperature Shutdown is meaningless and cannot be generated.

## 5.2 CHANGING AN EVENT RESPONSE CONFIGURATION

To change an event response configuration, the control must be in **STOP** mode.

Here are the steps to access event response configurations on the EMCP 4 display.

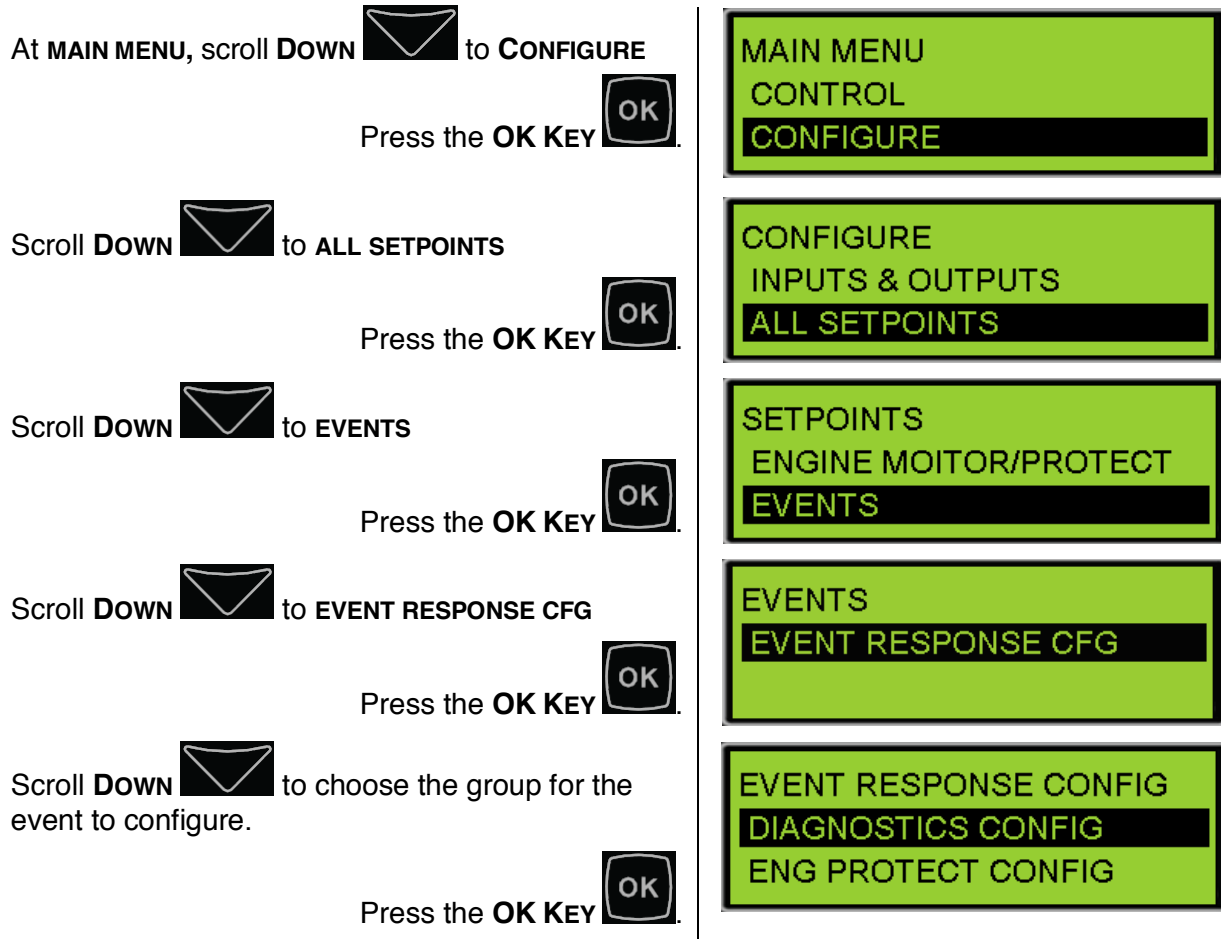

The group name should help find the setpoint. However, a list of setpoints in each group, or submenu is given in Table 3.

<b>Diagnostics Config</b>	<b>Engine Protection Config</b>	<b>Generator Protection Config</b>	<b>Custom Event Config</b>	<b>Other System Config</b>
<ul style="list-style-type: none"> <li>• Accessory Data Link*</li> <li>• Engine Speed</li> <li>• Primary Data Link</li> <li>• SCADA Data Link*</li> <li>• Batt Charger Fail</li> <li>• Eng Cont Not Resp</li> <li>• RS485-Annunciator Data Link*</li> <li>• Analog Inputs</li> </ul>	<p><b>Pressures</b></p> <ul style="list-style-type: none"> <li>• Engine Oil</li> <li>• Gas Pressure</li> </ul> <p><b>Temperatures</b></p> <ul style="list-style-type: none"> <li>• Engine Coolant</li> <li>• Engine Oil</li> <li>• Exhaust</li> </ul> <p><b>Levels</b></p> <ul style="list-style-type: none"> <li>• Engine Coolant</li> <li>• Engine Oil</li> <li>• Fuel</li> <li>• Ext Fuel Tank</li> </ul> <p><b>Others</b></p> <ul style="list-style-type: none"> <li>• Air Damper Closed</li> <li>• Unexpected Engine Shutdown</li> <li>• Overspeed</li> <li>• Underspeed</li> <li>• Emergency Stop</li> <li>• Fail to Start</li> <li>• Fuel Leak</li> <li>• Service Maintenance Interval</li> <li>• Engine Inlet Manifold Charge Combustion</li> <li>• Remote E-Stop</li> </ul>	<ul style="list-style-type: none"> <li>• Generator Rear Bearing Temperature</li> <li>• Generator Overcurrent</li> <li>• Generator Over Frequency</li> <li>• Generator Under Frequency</li> <li>• Reverse Power</li> <li>• Generator Over Voltage</li> <li>• Generator Under Voltage</li> <li>• Earth Fault</li> <li>• Generator Winding Temperature #1</li> <li>• Generator High Power</li> <li>• Reverse Reactive Power</li> </ul>	<ul style="list-style-type: none"> <li>• Digital Input Custom Events</li> <li>• Analog Input Custom Events</li> </ul>	<ul style="list-style-type: none"> <li>• Battery Voltage</li> <li>• Battery Charging System Voltage</li> <li>• Generator Breaker Open</li> <li>• Generator Breaker Closed</li> <li>• Engine in Cooldown</li> <li>• Speed-Frequency Mismatch</li> <li>• Not in Auto</li> <li>• Earth Leakage</li> <li>• EPS Supplying Load</li> <li>• Battery Cranking Voltage</li> </ul>

\*EMCP 4.2 only

**Table 3: Event Response Configuration Setpoints**





**EXAMPLE:**Select **ENGINE PROTECTION CONFIG**Press the **OK KEY** Select **PRESSURES**Press the **OK KEY** 

To edit a setpoint, press the **RIGHT ARROW**  key to highlight **EDIT**.

This brings up a list of event response configuration setpoints. Use the Up or Down arrows to scroll through the list.

**Note:** This will only work if the control is in **STOP** mode. Some setpoints cannot be configured, or require a minimum security level. Those setpoints will display a lock icon to the right of the **EDIT** text.

Then, press the **OK KEY**  to edit the setpoint.

Use the **LEFT ARROW**  and **RIGHT ARROW**  to toggle between checked and unchecked, and use the **UP ARROW**  and **DOWN ARROW**  to move between the responses.



In this group of event response configurations, there are four types of events, grouped by the type of data: Pressures, Temperatures, Levels, and Others (such as status).

Here you can edit individual responses, as described above.

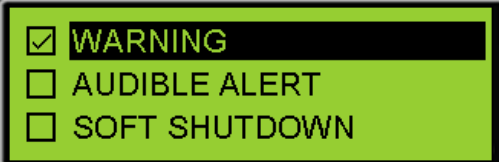

Some responses are fixed and cannot be disabled. For those responses, a lock will be displayed instead of a checkbox.

### 5.3 RESETTING INDIVIDUAL ACTIVE EVENTS FOR THE EMCP 4

There are three ways to reset events. One way, described in this chapter, which applies to the EMCP 4 GSC only (the “Genset Control” log), is to reset individual Active events by navigating to the desired event in the event log, described below.

The second way, which applies to all modules other than the EMCP 4, is to reset all Active events in that module’s event log by navigating to one of the Active events in that event log (see Chapter 5.4).

The third way is an approach that resets all Active events for all modules (see Chapter 5.5). With any of these methods, you must be in **STOP** mode.

To reset individual events on the EMCP 4, start by navigating to the event log:



At **MAIN MENU** Select **VIEW** by pressing the





Alternately, press the **EVENT LOG BUTTON** to access the **EVENT LOG**.

Select **EVENT LOGS** by pressing the **OK KEY**



Scroll up  or down  to select the **GENSET CONTROL LOG**

Press the **OK KEY** 

Scroll up  or down  through the list of events and find the **ACTIVE** event that requires resetting.

Generally, events are ordered by the status of the event; **PRESENT** events are listed first, followed by **ACTIVE** events, and finally the **INACTIVE** events. Within each status, the events are listed with the most recent first.

Press the **OK KEY**  to enable the reset feature.

Press the **OK KEY**  to reset the event. Notice that the event changes from Active to Inactive.



In this example image, there is one **PRESENT** or **ACTIVE** event under Genset Control #1.

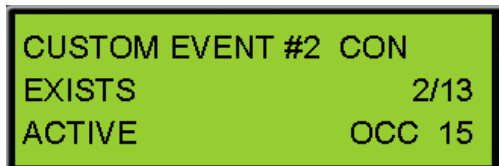

## 5.4 RESETTING ALL ACTIVE EVENTS FOR A SINGLE MODULE

The second way to reset events, described in this chapter, which applies to all modules other than the EMCP 4, is to reset all of the module's Active events by navigating to one of the Active events in the event log. This method doesn't apply to the EMCP 4 GENSET CONTROL log. For information on resetting events on the EMCP 4, see chapters 5.3 or 5.5.

With any method, you must be in **STOP** mode. A key difference between the EMCP 4 and all other modules is that the other modules don't display a **PRESENT** status for events.

Events are shown as **ACTIVE** if they are currently affecting the system, or as **INACTIVE** if they are not.

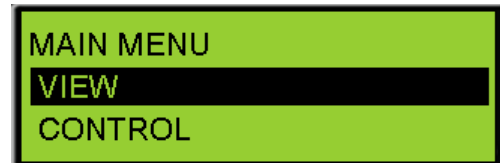

To reset all of a modules Active events on any individual module except the EMCP 4 (listed as **GENSET CONTROL** in the event log), start by navigating to the event log.

At **MAIN MENU** scroll **DOWN**  to **VIEW** by pressing the **OK KEY** .



Select **EVENT LOGS** by pressing the **OK KEY** .



Scroll **UP**  or **DOWN**  to select the desired log and

ACTIVE EVENTS	4
GENSET CONTROL	2
<b>EXTERNAL I/O #1</b>	<b>2</b>

Press **OK KEY** .

Press **OK KEY**  to view the first event details.

LOW FUEL LEVEL	
SHUTDOWN	1/2
ACTIVE	OCC 44

Pressing the **OK KEY**  will allow an option to **RESET** all events in the selected module.

SPN 96	FMI 1
ACTIVE	<b>RESET MOD</b>
NUM OCCURRENCES	2

Pressing the OK key will reset all of the **ACTIVE** events in that module's event log that can be reset.

SPN	FMI
NUM OCCURRENCES	

**Note:** Modules other than the EMCP 4 cannot display events as **PRESENT**.

If pressing **OK KEY**  at **RESET ALL** doesn't reset all of the events, the condition causing the event being viewed may still be present. For example, if the engine shut down on high coolant temperature, then the events will not reset until the coolant temperature drops below the shutdown threshold.

## 5.5 RESETTING ALL ACTIVE EVENTS FOR ALL MODULES

The third way to reset events, described in this chapter, is a shortcut that resets all Active events for all modules. With any method, you must be in **STOP** mode.

Once all of the condition(s) that are causing the events have been corrected, all Active events (those for which the condition is not present) on all modules can be reset using the **RESET ALL EVENTS** feature.

In order to do this, the control must be in **STOP** mode and engine speed should be zero.

**FROM ANY SCREEN:**

Press the **RESET KEY** .

A confirmation prompt will appear.

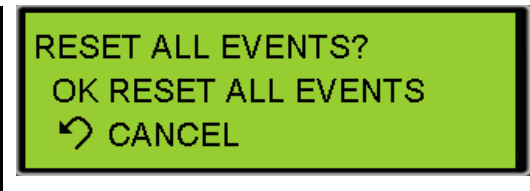

Pressing the **OK KEY**  will continue and **RESET** all events on all modules.

Pressing the **ESCAPE KEY**  will **CANCEL** the reset operation.

The controller will display which events were reset, and which ones were not.

**Note:** Reset All Events will not reset Present events! For example, if the E-Stop switch is pressed and an **EMERGENCY STOP SHUTDOWN** is present, it cannot be reset until the E-Stop is pulled out and the event status changes from **PRESENT** to **ACTIVE**.

## 5.6 RESETTING EVENTS FOR ENGINE ECMS WITHOUT PRIMARY CAN DATA LINK SUPPORT

The EMCP 4 has the ability to reset all events for electronic engines with no PRIMARY CAN support by means of a Relay Output. A number of conditions must be satisfied in order for this to work.

- FIRST:** One of the Outputs must be configured as a Command/Status for **ECU FAULT RESET**. See Chapter 10.
- SECOND:** The corresponding output must be wired to a corresponding Fault Reset I/O pin on the engine ECM or it must be setup to power cycle the ECM.

**THIRD:**



Pressing the **RESET ALL KEY** with this option selected will activate the **ECU FAULT RESET**, which will activate the corresponding Relay Output and trigger the engine ECU to reset its faults or will power cycle the ECU. This will only active the ECU FAULT RESET OUTPUT if the EMCP has a warning or fault. This warning or fault can be triggered by using a custom event on a digital input that is wired to the fault alarm of the ECU.

## 5.7 TROUBLESHOOTING RESETTING EVENTS

There are common reasons for the EMCP 4 not allowing events to be reset. First of all, in order to reset any event, the EMCP 4 must be in STOP mode. In order to reset engine ECM events, the engine speed must also be zero.

**SERVICE MAINTENANCE INTERVAL WARNING** and **NOT IN AUTO WARNING** are explained more fully below.

### NOT IN AUTO WARNING

This event is Present whenever the control is in either RUN or STOP. As a result, it cannot be reset in STOP (since the event is present). The event will reset when the



control is returned to **AUTO**. This event can be disabled by modifying the GENERATOR CONTROL NOT IN AUTOMATIC WARNING EVENT RESPONSE CONFIGURATION setpoint. See Chapter 7 for instructions on editing that setpoint.

### SERVICE MAINTENANCE INTERVAL (EMCP 4.2 ONLY)

If a **SERVICE MAINTENANCE INTERVAL WARNING** is **PRESENT**, it **cannot** be reset. The warning is PRESENT because the countdown timer has reached zero. To clear the warning, the timer must be reset, rather than the event. When the timer is reset, it returns to the programmed interval (default is 180 calendar days or 500 engine hours). This timer must be reset from the display; it cannot be reset by using the Service Tool alone. This warning can only be disabled by using the Event Response Configuration. See Chapter 5.2.

**Note:** This warning does not appear on the face of the EMCP 4 as a flashing LED unless configured to do so within Cat ET under Event Response Configuration – Engine Protection Events.

**TO VIEW THE TIMER SETTINGS ON THE DISPLAY:**

At **MAIN MENU** scroll **DOWN**  to **CONFIGURE**

Press the **OK KEY** 



Scroll **DOWN**  to **RESET COUNTER**

Press the **OK KEY** 



Scroll **DOWN**  until you reach **SERVICE MAINTENANCE INTERVAL**

Press the **OK KEY** 



The **SERVICE MAINTENANCE INTERVAL HOURS** is displayed.



Scroll **DOWN**  to view the **SERVICE MAINTENANCE INTERVAL DAYS**

Press the **OK KEY** 



Scroll **DOWN**  to view the **PASSWORD REQUIRED TO RESET THE SERVICE MAINTENANCE INTERVAL.**

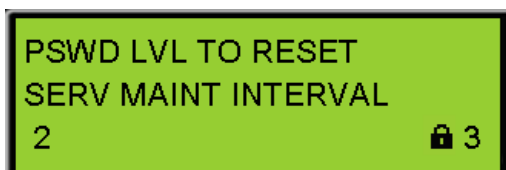
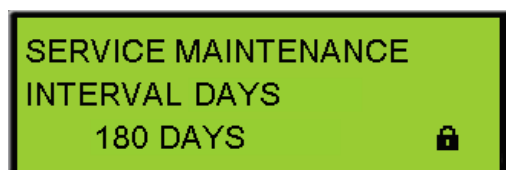

The security level required is level 3 but, the required security level can be changed by using the Service Tool.





**TO RESET THE TIMER ON THE DISPLAY:**

At **MAIN MENU** scroll **DOWN**  to **CONFIGURE**  
Press the **OK KEY** .

Scroll **DOWN**  to **RESET COUNTERS**  
Press the **OK KEY** .

Scroll **DOWN**  to **SERV MAINT INTERVAL**  
Press the **OK KEY** .

**RESET SERV INTVL?** is highlighted. To **RESET** the service interval press the **OK KEY** .

A confirmation prompt will appear. Pressing the **OK KEY**  will continue and **RESET** the service maintenance interval. Pressing the **ESCAPE KEY**  will **CANCEL** the reset operation.

The new Service intervals will be displayed.



MAIN MENU  
CONTROL  
CONFIGURE



CONFIGURE  
RESET COUNTERS  
TIME/DATE



RESET COUNTER  
RESET START COUNTER  
SERV MAINT INTERVAL



SERV: 482 HOURS  
OR 175 DAYS  
RESET SERV INTVL?

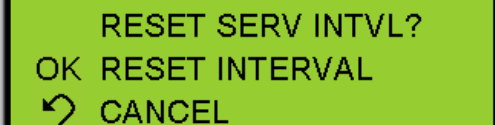

RESET SERV INTVL?  
OK RESET INTERVAL  
↶ CANCEL



SERV: 500 HOURS  
OR 180 DAYS  
RESET SERV INTVL?

**TO ADJUST THE TIMER SETTINGS FROM CAT ET, DO THE FOLLOWING:**

1. Connect to the EMCP 4 using the Cat Service Tool as stated in Chapter 4.2.
2. Select Service Maintenance Interval on the left.

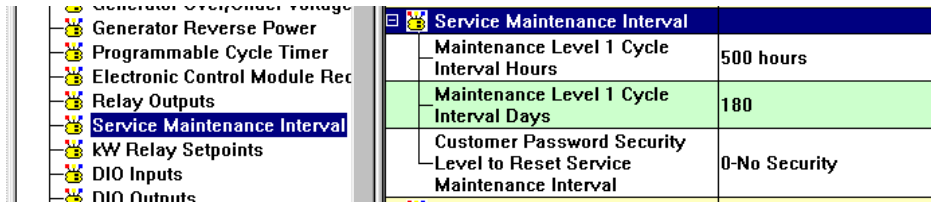

3. Double click Maintenance Level 1 Cycle Interval Hours on the right to enter a new interval.

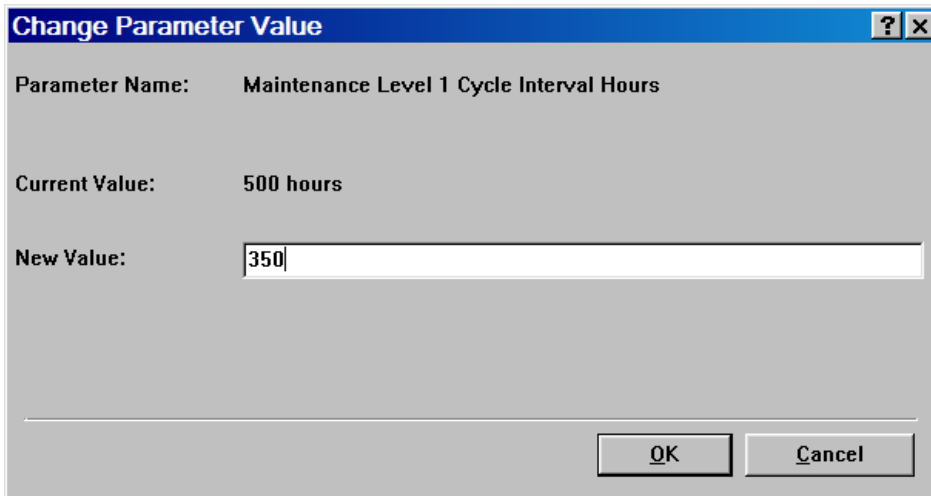

4. Double click Maintenance Level 1 Cycle Interval Days on the right to enter a new interval.

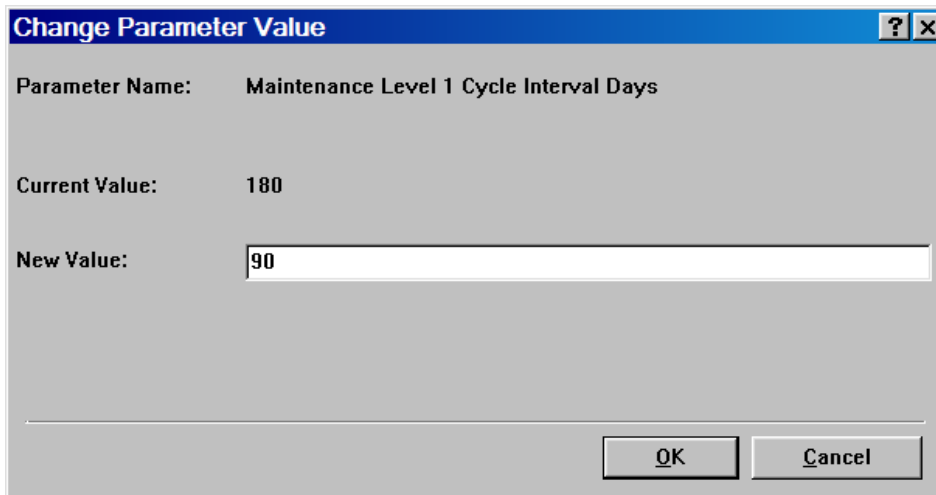

5. Double click Customer Password Security Level to Reset Service Maintenance Interval on the right to enter a new security level.

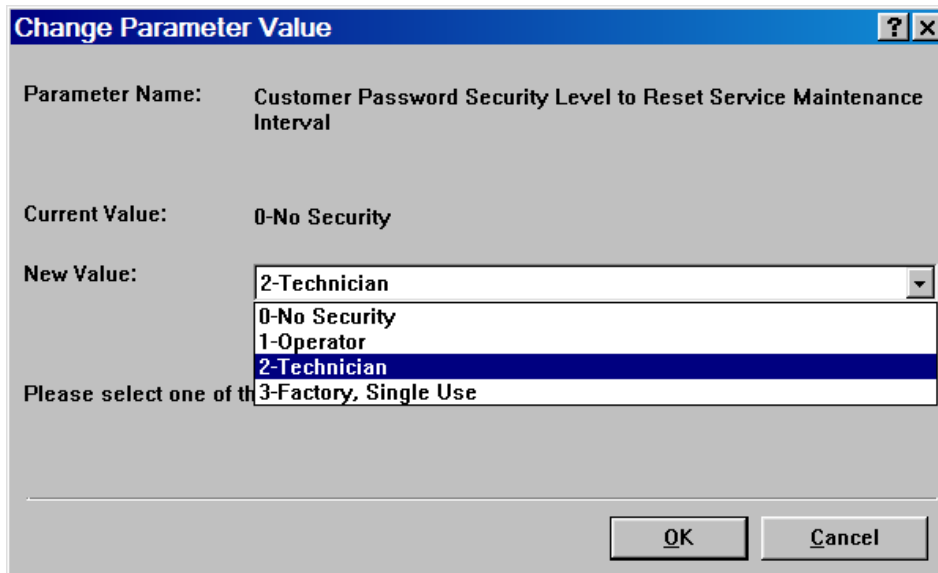

**Caution:** Be sure to change the password level back to **LEVEL 3** after the reset, to prevent inadvertently resetting the timer at other times!

---

## 6 SECURITY

There are five levels of security access on EMCP 4: **LEVEL 0**, **LEVEL 1**, **LEVEL 2**, **LEVEL 3**, and **SERVICE TOOL**. Any configurable parameter or function that is set to Level 0 can be accessed by anyone at any time, and there will never be any security information on the display screen.

**LEVEL 1 ACCESS** and **LEVEL 2 ACCESS** represent increasing levels of access to the setpoints and functions of the controller. Both levels 1 and 2 can be password protected with separate user-defined passwords.

**Note:** These are optional levels of security; by default these passwords are disabled, and the default access level is LEVEL 2 from Parts Service.

**LEVEL 3 ACCESS** is password protected at the factory, and requires contacting the Cat **DEALER TC** to obtain a password.

If the present security level of the controller is below the level needed to perform a desired function, a padlock and a number will be displayed at the bottom right hand corner of the display. The number represents the level of security that is required in order to perform the desired function; 1, 2, or 3.

If there is a padlock but no number, then the Cat Service Tool is required in order to perform the desired function; or the setpoint may be read only and cannot be changed.

All of the adjustable parameters are associated with a specific level of security required to make an adjustment to the parameter. Certain functions, such as resetting the number of crank attempts, are also associated with a specific level of security. The passwords only affect actions taken at the EMCP 4. Access of the EMCP 4 remotely via the Cat Service Tool or via the SCADA data link is not affected by the security level on the EMCP 4 display.

Changing parameters with the Cat Service Tool does not require passwords, since the Service Tool already has the highest level of access.

When connecting via the **SCADA DATA LINK**, passwords can also be used. The levels of access granted via SCADA are identical to the levels of access granted at the EMCP 4. However, the passwords themselves may differ. Furthermore, the EMCP 4 and the SCADA data link may be at different levels of access at any given time. For more information about SCADA security see Chapter 18.

Level 1 and Level 2 passwords are usually **DISABLED** when shipped from the factory. Level 1 and Level 2 passwords can be user defined if desired. If the Level 1 and Level 2 passwords are not user defined, the Level 2 will be the **MINIMUM LEVEL**. All parameters that require Level 0, Level 1, or Level 2 security will be able to be changed by anyone at any time.

**Note:** The EMCP 4 will always move up in security level to the highest level of access that is not password protected when a certain level of access is requested. For example, if a Level 1 password has been defined, but a Level 2 password has not, the EMCP 4 will start at Level 0 on power up. When the Level 1 password is entered, the EMCP 4 will move up to Level 2 access.

**THE SECURITY MENU**

To get to the security menu:

At **MAIN MENU** scroll **DOWN**  to Configure

Press the **OK KEY** .

At **SECURITY**, press the **OK KEY** .

The **SECURITY MENU** will show the current level of security at the top of the screen.

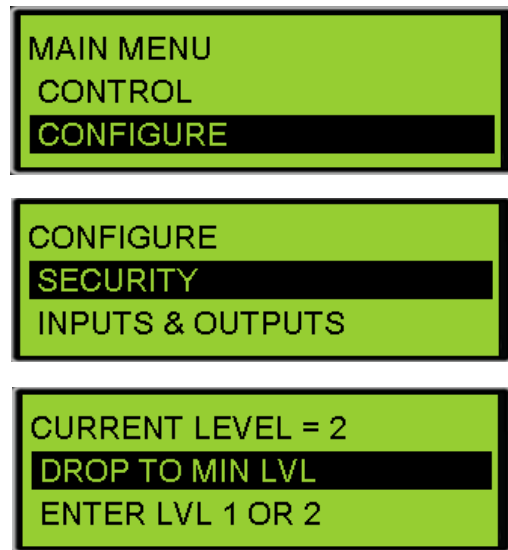

There are six options on the security menu:

DROP TO MIN LEVEL

ENTER LEVEL 1 or 2

ENTER LEVEL 3

CHANGE LVL 1 PSWD

CHANGE LVL 2 PSWD

CHANGE SCADA PSWD



Selecting **DROP TO MIN LEVEL** will make the control go to the minimum level of security. As previously discussed, if the level 1 and level 2 passwords are not defined by the user, the minimum level of security will be level 2. If a level 2 password is defined by the user, but not a level 1 password, then the minimum level of security will be level 1.

In contrast, if a level 1 password is defined by the user, but not a level 2 password, then the minimum level of security will be level 0.

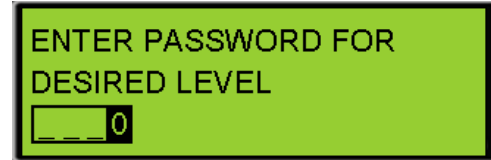
Selecting **ENTER LEVEL 1 OR 2** will open up a password entry screen.



The password entry screen will have 4 spaces. In each space a numbers from 0 through 9 can be entered. The password can be from 1 to 4 digits and is entirely user defined. Enter the password for either level 1 or level 2 if either of those passwords have been defined. Use the **UP**

**ARROW**  or **DOWN ARROW**  to change the value of any highlighted digit. Use the

**LEFT ARROW**  or **RIGHT ARROW**  to navigate between digits.

Selecting **ENTER LEVEL 3** will cause the display to say “**PHONE IN WITH**” and a 16 digit number will be displayed. Under that, **ENTER RESPONSE** will be highlighted. Record the 16 digit number and call the Cat Dealer TC with this number. The TC will reply with another 16 digit number.



Press the **OK KEY**  from the **PHONE IN WITH** screen, and a password entry screen will be displayed. Enter the password that was supplied by the TC in the same manner as the other types of passwords.

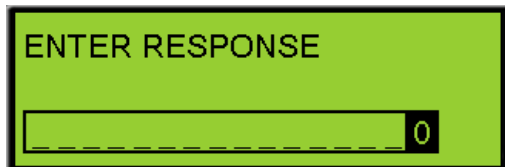

Press the **OK KEY**  to confirm, or **ESCAPE KEY**  to reject the change. Pressing the **OK**

**KEY**  after entering the number will set the current level to 3. The control will remain in level 3 security level until no key presses have been made for 10 minutes. After 10 minutes of inactivity the control will revert back to the minimum level of security.

**Note:** To change a level 3 parameter requires either a level 3 password from the TC or a PC connection using a Service Tool. Therefore, if you have a Service Tool, try to change the parameter using the Service Tool rather than calling the TC.

Selecting **CHANGE LVL 1 PSWD** will allow for the level 1 password to be changed. The control must be at level 1 security in order to select **CHANGE LVL 1 PSWD**. The **CHANGE LVL 1 PSWD** screen looks just like the password entry screen. It has 4 blank spaces that can each be set to a number from 0 to 9. The password can use as few as one digit and can use as many as 4 digits. It is entirely up to the user. If a password has been set but, it is now desired to **not** have level 1 password protection, the level 1 password can be disabled by setting the password to be a single 0.

Once the desired password is entered, press the **OK KEY**  and the control will go back to the security screen and the level 1 password will be set.

Selecting **CHANGE LVL 2 PSWD** will allow for the level 2 password to be changed. The control must be at level 2 security in order to select **CHANGE LVL 2 PSWD**. The **CHANGE LVL 2 PSWD** screen looks just like the password entry screen. It has 4 blank spaces that can each be set to a number from 0 to 9. Selecting a password is entirely up to the user and can use as few as one digit or as many as 4 digits.

The level 2 password can be disabled by setting the password to be a single 0.

Once the desired password is entered, press the **OK KEY**  and the control will go back to the **SECURITY SCREEN** and the level 2 password will be set.

Selecting **CHANGE SCADA PSWD** will allow for the SCADA password to be changed.

This password, if **ENABLED**, will require a SCADA system to first enter the password into the **WRITE ACCESS PASSWORD** register prior to conducting any other reads and writes. The control must be at level 2 security in order to select **CHANGE SCADA PSWD**. The **CHANGE SCADA PSWD** screen looks just like the password entry screen. It has 8 blank spaces that can each be set to a number from 0 to 9. The password can use as few as one digit and can use as many as 8 digits.

Just as with level 1 and level 2 passwords, entering a single 0 will **DISABLE** the SCADA password.

## 7 SETPOINTS

The EMCP 4.1 and 4.2 have a variety of setpoints that can be programmed or adjusted. These setpoints can be adjusted via the display, or via the Cat Service Tool. In order to program the setpoints via the display, go through the following menu options:

At **MAIN MENU** scroll **DOWN**  to **CONFIGURE**

Press the **OK KEY** .

Scroll **DOWN**  to **ALL SETPOINTS**

Press the **OK KEY** .

MAIN MENU  
 CONTROL  
**CONFIGURE**

CONFIGURE  
 INPUTS & OUTPUTS  
**ALL SETPOINTS**







All of the setpoints on EMCP 4 can be accessed through this menu. However, setpoints related to input and output configuration can also be accessed through the **INPUTS AND OUTPUTS** menu under **CONFIGURE**. It is recommended to use the latter to configure inputs and outputs. For more information on configuring inputs and outputs, see Chapter 8 through 10.

### 7.1 CONFIGURING SETPOINTS

Setpoints can be one of four different types: **NUMERICAL ENTRY**, **SELECTION**, **SUSPECT PARAMETER NUMBER**, or **EVENT RESPONSE**. Each type is configured differently. For configuring any setpoint via the display, the user must first have the proper security access. See Chapter 6 for more information on security.



**NUMERICAL ENTRY** setpoints are parameters like time delays, thresholds, etc. For these setpoints the display will show the current value.



To change the value of a **NUMERICAL ENTRY** type setpoint:

1. Press the **OK KEY**  when the setpoint is highlighted. The current value of the setpoint will be shown with the rightmost digit highlighted.
2. Use the **UP**  and **DOWN**  arrow keys to adjust that digit to the desired value. Digits will wrap around. Therefore, pressing up when 9 is shown will change it to 0, or pressing down when 0 is shown will change it to 9.
3. Once that digit is set to the desired value, use the **LEFT**  arrow key to move the cursor to the next digit.
4. Then use the **UP**  and **DOWN**  arrow keys to adjust that digit to the desired value.
5. Continue this process until the desired value for the setpoint is set.

6. Then press the **OK KEY**  to save the value.





Tip: You can quickly select the largest possible value for the setpoint by pressing the

**LEFT**  arrow key until the leftmost digit is shown, and then pressing the **UP**  arrow key until the value stops changing. Similarly you can select the smallest possible

value by pressing the **LEFT**  arrow key until the leftmost digit is shown, and then pressing and holding **DOWN**  arrow key until the value stops changing.

**SELECTION** type setpoints, such as Generator Configuration, or Active State, have options that are not numerical. For these setpoints, the display will show the current setting.

To change the value of a **SELECTION** type setpoint:









1. Press the **OK KEY**  when the setpoint is highlighted. The current setting of the setpoint will be shown.
2. Use the **UP**  or **DOWN**  arrow keys to scroll through the options that are available for that setpoint. Scroll quickly by holding the key.
3. When the desired option is displayed, press the **OK KEY**  to save the setting.

**SUSPECT PARAMETER NUMBER** type setpoints are similar to **SELECTION** type setpoints, but the selections are grouped into four groups:

1. Pressures
2. Temperatures
3. Levels
4. Others

Any selection with units that are not pressure, temperature, or percent will be in the “Others” group. This group also contains Custom Parameters and Custom Events. Suspect parameter numbers indicating status (like Gen Breaker Open) will also be here.

To change the value of a **SUSPECT PARAMETER NUMBER** type setpoint:

1. Press the **OK KEY**  when the setpoint is highlighted. Notice here that the setpoint value is not shown. Instead, the first group name, PRESSURE, is shown.
2. Use the **UP**  or **DOWN**  arrow keys to scroll through the four groups: PRESSURE, TEMPERATURE, LEVEL, OTHERS.
3. When the desired option is displayed, press the **OK KEY**  to see the suspect parameter numbers (by name) in that group.
4. Use the **UP**  or **DOWN**  arrow keys to scroll through the suspect parameter numbers (by name) until the desired one is selected.
5. Press the **OK KEY**  to save the setting. Alternately, press the **BACK**  key to return to the group selection: PRESSURE, TEMPERATURE, LEVEL, OTHERS.

**EVENT RESPONSE CONFIGURATION** type setpoints are a little different from the previously discussed setpoints. Each setpoint configures one or more actions that occur when the event occurs. See Chapter 5.1 for more information.

## 7.2 SETPOINTS ON THE EMCP 4 DISPLAY

The setpoints in the EMCP 4 are organized into multiple submenus. See Appendix A and the appropriate sections of this document for more information.

## 7.3 SETPOINTS ON THE CAT SERVICE TOOL

EMCP 4 setpoints can be configured using the Cat Service Tool (ET). To access setpoints, see Chapter 4.2.

If a value is changed from the EMCP display, Cat ET will not refresh the setpoint automatically. Press the “Config Tool” icon to refresh the list.

Categories of setpoints are listed along the left pane, and clicking on one of them will bring up that list in the right pane.

The EMCP 4.1 and 4.2 have different numbers of setpoints. The categories shown here match those in ET version 2010C. Older versions may have less, and newer versions may have more.

**Note:** Any setpoint with a value given as Unavailable is not applicable to that level of EMCP 4.

## **SETPOINT CATEGORIES**

Here are the categories of setpoints as found in the left pane of the ET Configuration Tool:

### **ANALOG INPUTS**

Setpoints related to Analog Inputs. See Chapter 9.

### **AUTOMATIC START/STOP**

Setpoints related to starting and stopping the generator set, as well as engine configuration.

### **BATTERY VOLTAGE MONITOR**

Setpoints related to monitoring battery voltage from the battery power input to the EMCP 4.

### **CRANK ATTEMPT/SUCCESSFUL START COUNTER**

Setpoint related to crank/start counters.

### **RS-485 SCADA DATA LINK (EMCP 4.2 ONLY)**

Setpoints related to SCADA (Modbus) data link communications. See Chapter 18.

### **DIGITAL INPUTS**

Setpoints related to Digital Inputs. See Chapter 8.

### **DIGITAL OUTPUTS**

Setpoints related to the polarity of Digital Outputs. See Chapter 10.

### **ENGINE COOLANT TEMPERATURE MONITOR**

Setpoints related to monitoring engine coolant temperature.

### **ENGINE OIL PRESSURE MONITOR**

Setpoints related to monitoring engine oil pressure.

### **ENGINE SPEED MONITOR**

Setpoints related to monitoring engine speed using the Magnetic Pick-Up (MPU) input.

### **ENHANCED ENGINE MONITOR**

Setpoints related engine cylinder temperature monitoring via the optional Thermocouple module. Applies to EMCP 4.2 only.

### **ENHANCED GENERATOR MONITOR**

Setpoints related to generator bearing and winding temperature monitoring via the optional RTD module. Applies to EMCP 4.2 only.

### **EVENT RESPONSE CONFIGURATION - DIAGNOSTIC EVENTS**

Setpoints used to configure the EMCP 4 response to diagnostic events. See Chapter 5.7.

### **EVENT RESPONSE CONFIGURATION - ENGINE PROTECTION EVENTS**

Setpoints used to configure the EMCP 4 response to engine protection events. See Chapter 5.

**EVENT RESPONSE CONFIGURATION - GENERATOR PROTECTION EVENTS**

Setpoints used to configure the EMCP 4 response to generator protection events. See Chapter 5.

**EVENT RESPONSE CONFIGURATION - OTHER SYSTEM EVENTS**

Setpoints used to configure the EMCP 4 response to events that do not fit into the category of diagnostics, engine protection, or generator protection. See Chapter 5.

**EVENT RESPONSE CONFIGURATION – CUSTOM EVENTS**

Setpoints used to configure the EMCP 4 response to custom events. See Chapter 5.

**FUEL TRANSFER**

Setpoints related to fuel transfer feature.

**GENERATOR AC MONITOR**

Setpoints related to generator configuration (for EMCP 4 calculation and reporting).

**GENERATOR AC POWER MONITOR (EMCP 4.2 ONLY)**

Setpoints related to generator power monitoring.

**GENERATOR CURRENT MONITORING (EMCP 4.2 ONLY)**

Setpoints related to generator AC overcurrent monitoring.

**GENERATOR OVER/UNDER FREQUENCY**

Setpoints related to generator overfrequency and underfrequency monitoring.

**GENERATOR OVER/UNDER VOLTAGE**

Setpoints related to generator AC overvoltage and undervoltage monitoring.

**GENERATOR REVERSE POWER (EMCP 4.2 ONLY)**

Setpoints related to generator AC reverse power monitoring.

**PROGRAMMABLE CYCLE TIMER (EMCP 4.2 ONLY)**

Setpoints related to configuring Programmable Cycle Timers. See Chapter 13.

**ELECTRONIC CONTROL MODULE REDUCED POWER MODE**

Setpoints related to a power-saving mode of the EMCP 4 called Reduced Power Mode. See Chapter 14.

**RELAY OUTPUTS**

Setpoints related to Relay Outputs. See Chapter 10.

**SERVICE MAINTENANCE INTERVAL**

Setpoints related to configuring and resetting the timers used to indicate a service needed warning. See Chapter 5.7.

**KW RELAY SETPOINTS**

Setpoints related to configuring the behavior of the Trip Point function, which is used to indicate that the generator is approaching overload.

**DIO INPUTS**

These setpoints are not currently used. Currently programmed in the DIO module.

**DIO OUTPUTS**

These setpoints are not currently used. Currently programmed in the DIO module.

**CONFIGURATION DATA**

Contains the Engine Serial Number setpoint, which is read-only.

**DISPLAY PREFERENCES**

Setpoints determining the units used on the EMCP 4 display. Note that this does not affect the data as viewed on the Cat Service Tool. See Chapter 4.4.

## 8 DIGITAL INPUTS

The EMCP 4.1 and 4.2 have six user-programmable Digital Inputs. The user programmable Digital Inputs are referenced to Battery (-) and will see a change in state at ~3VDC with a 1VDC hysteresis. The Digital Inputs seen on the display that are labeled “A” and “B” are reserved for E-Stop and Remote Start.

The programming of the Digital Inputs starts by selecting a “Usage Type“. The rest of the programming is dependent upon what Usage Type is selected. Figure 17 summarizes the paths possible for Programming a Digital Input.

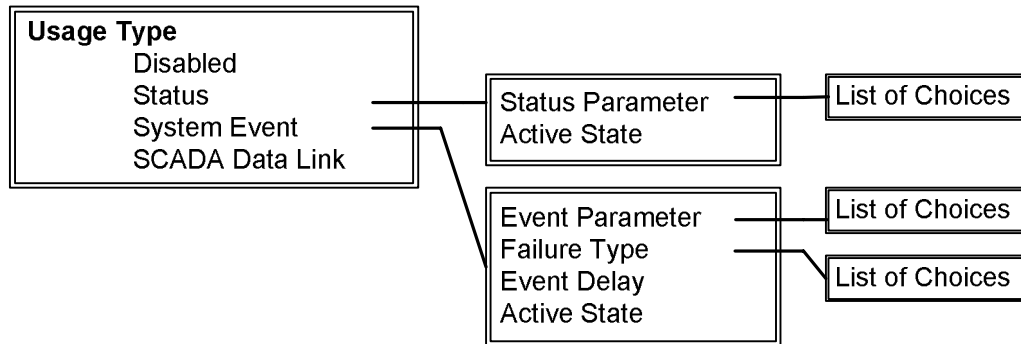

**Figure 17: Digital Input Programming Paths**

The Usage Type of **DISABLED** is used to completely disable the input. No status will be shown, and no action will be taken by the EMCP 4.

The Usage Type of **COMMAND/STATUS** is used to make certain system conditions be known by the EMCP 4; an example of a Command/Status event is the Idle Mode command.

The Usage Type of **SYSTEM EVENT** is used to inform the EMCP 4 of system conditions that require the EMCP 4 to trigger an event.

The Usage Type of **SCADA DATA LINK** is used to bring in digital input to the EMCP 4 for express use by the SCADA data link. EMCP 4 will not take any action or trigger any events on such an input.

The Digital Inputs of the EMCP 4 are tied to an internal pull-up resistor inside the controller. Therefore, if a Digital Input is **UNCONNECTED**, the Digital Input will sit at a **PHYSICAL HIGH** state. See Figure 18. Note that a Digital Input wired to battery positive will always remain Active if programmed for Active High, and will always remain Inactive if programmed for Active Low.

A battery negative input should be switched to each EMCP 4 Digital Input for proper operation.

If an **ACTIVE HIGH** configuration is desired, the battery negative input should be wired through a normally-closed switch.

If an **ACTIVE LOW** configuration is desired, the battery negative input should be wired through a normally-open switch.

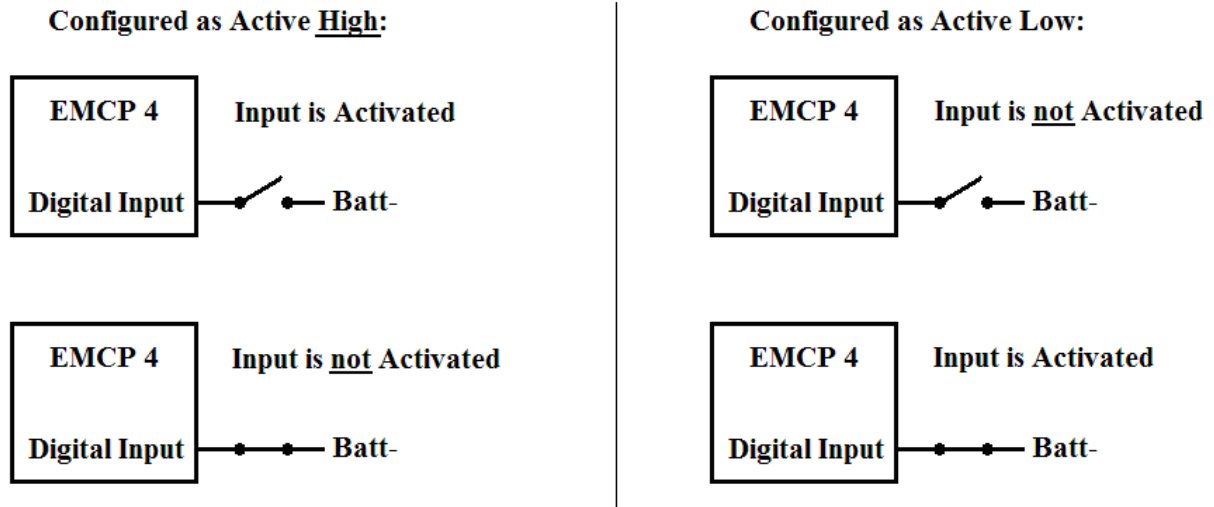

**Figure 18: Valid States of Digital Input Wiring and Configuration**

**Note:** Improper configuration of these inputs can cause a false event to be triggered, or cause an event to not be triggered when desired.

**Note:** If more than one Digital Input is configured for the same physical quantity (i.e. the setpoint Digital Input Data Identification matches between two Digital Inputs), then the higher numbered Digital Input value will have priority. For example, if both Digital Input #4 and Digital Input #5 are configured for ECS in Run but Digital Input #4 is activated with Digital Input #5 left inactive, then Digital Input #4 will be ignored.

## 8.1 PROGRAMMING DIGITAL INPUTS USING THE DISPLAY

The steps to configure the Digital Inputs for each of the Usage Types are described below.

**VIEWING THE CURRENT DIGITAL INPUT STATUS**

To view the current status of a Digital Input, go through the following menu options:

AT THE MAIN MENU, scroll DOWN  TO VIEW

Press the OK KEY 

Scroll DOWN  TO I/O STATUS

Press the OK KEY 

Press the OK KEY  to access DIGITAL INPUTS.

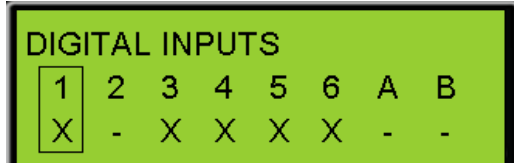
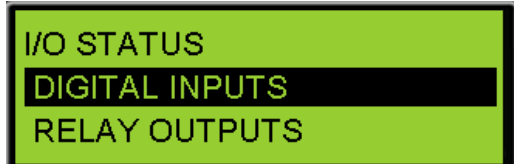

The status of all Digital Inputs is shown.  
 A dash under an input number (or letter) indicates an input that is programmed, but inactive. A large "X" under an input number (or letter) indicates an input that is disabled. A number (or letter) under an input number (or letter) indicates an input that is programmed and active.

With the LEFT ARROW  or RIGHT ARROW , select the DIGITAL INPUT that you want to view, then press the OK KEY .

The programmed Usage Type of the selected Digital Input is shown.

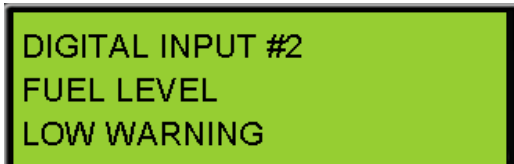

Scroll DOWN  to view the remaining parameters for this input:

- Usage Type
- Delay Time
- Physical State
- Logical State
- Active State

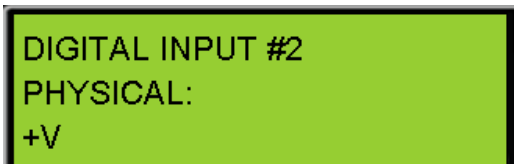

## CONFIGURING DIGITAL INPUTS FOR STATUS PARAMETERS

Command or Status parameters are used to control specific functions within the control system or to make certain conditions within the system be known. To configure a Digital Input as a Command or Status Parameter, go through the following menu options:

AT THE MAIN MENU, scroll DOWN  TO CONFIGURE

```
MAIN MENU
CONTROL
CONFIGURE
```

Press the OK KEY 

Scroll DOWN  to INPUTS & OUTPUTS

Press the OK KEY 

```
INPUTS & OUTPUTS
DIGITAL INPUTS
RELAY OUTPUTS
```

Alternately, access to the INPUTS & OUTPUTS submenu is accessible from ALL SETPOINTS.

Press the OK KEY  to access DIGITAL INPUTS.

```
DIGITAL INPUTS
INPUT #1
INPUT #2
```

Select the DIGITAL INPUT that you want to program

Press the OK KEY 

```
DIGITAL INPUT #1
USAGE TYPE
DISABLED
```

Press the OK KEY  to highlight the current configuration (DISABLED, STATUS, SYSTEM EVENT, OR SCADA).

```
DIGITAL INPUT #1
USAGE TYPE
DISABLED
```

Scroll DOWN  to STATUS

Press the OK KEY 

```
DIGITAL INPUT #1
USAGE TYPE
STATUS
```

Scroll DOWN  to STATUS PARAMETER

Press the OK KEY  to highlight the current STATUS PARAMETER.

```
DIGITAL INPUT #1
STATUS PARAMETER:
ECS IN STOP
```

Select the **STATUS PARAMETER** that you want to program

Press the **OK KEY** 

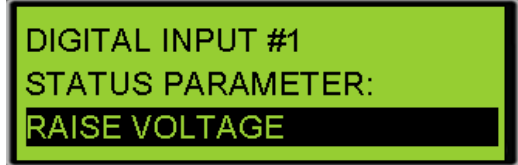

Scroll **DOWN**  to **ACTIVE STATE**

Press the **OK KEY**  to highlight the current **ACTIVE STATE**.



Select the **ACTIVE STATE** that you want to program and

Press the **OK KEY** 



Any Digital Input can be configured for any one of the Status parameters in Table 4:

ECS in Run*	Lower Voltage
ECS in Auto*	Raise Speed
ECS in Stop*	Lower Speed
Idle Mode Command	Auto Load Fuel
Inhibit Cooldown	Start Aid Timer Bypass
Raise Voltage	
*If a Digital Input is programmed for ECS in Auto, or Run, or Stop, and a maintained switch latches that input to make it active, the front panel buttons will not have any effect.	

**Table 4: Digital Input Status Choices**

### CONFIGURING DIGITAL INPUTS FOR SYSTEM EVENTS

System Events are used to know when specific conditions are reached and to alert the control system of warning or shutdown conditions. To configure a Digital Input as a System Event, go through the following menu options:

AT THE MAIN MENU, scroll down  to CONFIGURE



Press the OK KEY 

SCROLL DOWN  to INPUTS & OUTPUTS



Press the OK KEY 

Alternately, access to THE INPUTS & OUTPUTS submenu is accessible from ALL SETPOINTS.

Press the OK KEY  to access DIGITAL INPUTS.

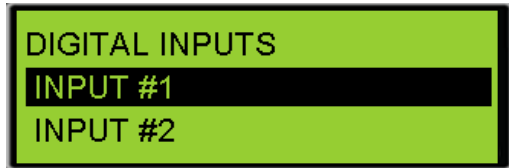

Select the DIGITAL INPUT that you want to program and

Press the OK KEY 

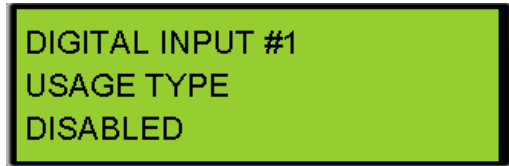

Press the OK KEY  to highlight the current configuration (DISABLED, STATUS, SYSTEM EVENT, OR SCADA).

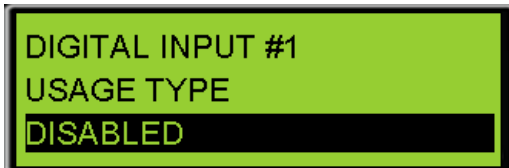

Scroll DOWN  to SYSTEM EVENT

Press the OK KEY 



Scroll DOWN  to EVENT PARAMETER

Press the OK KEY  to edit the current STATUS PARAMETER.



Select the type of EVENT PARAMETER that you want to program (Pressures, Temperatures, Levels, or Others)

Press the OK KEY 



Select the **EVENT PARAMETER** that you want to program

Press the **OK KEY** 



Scroll **DOWN**  to **FAILURE TYPE**

Press the **OK KEY**  to edit the current **FAILURE TYPE**.



Select the **FAILURE TYPE** that you want to program

Press the **OK KEY** 



Scroll **DOWN**  to **EVENT DELAY**

Press the **OK KEY**  to highlight the current **EVENT DELAY**.

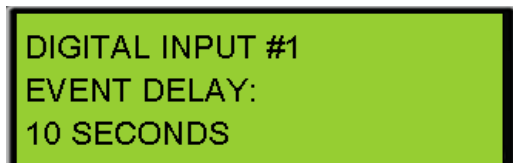

Select the **EVENT DELAY** that you want

Press the **OK KEY** 

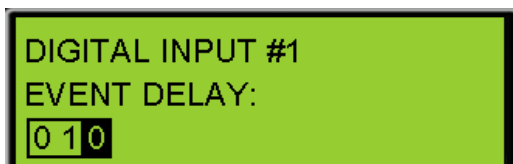

Scroll **DOWN**  to **ACTIVE STATE**

Press the **OK KEY**  to highlight the current **ACTIVE STATE**.



Select the **ACTIVE STATE** that you want to program and

Press the **OK KEY** 



Any Digital Input can be configured for any one of the System Event parameters in Table 5:

<p><b>Pressures</b></p> <p>Engine Oil Pres Gas Pressure</p>	<p><b>Others</b></p> <p>Custom Event Air Dmpr Closed Batt Chrgr Fail Fuel Leak Earth Fault Earth Leakage Bat Chg Sys Volt Gen Bkr Closed Gen Bkr Open Gen Current Gen Real Power In Man Chrg Comb EPS Supply Load (EMCP 4.2 only) Emrg Stop Switch</p>
<p><b>Temperatures</b></p> <p>Eng Coolant Temp Engine Oil Temp Exhaust Temp Gen Rear Brg Temp Gen Winding #1 Temp</p>	
<p><b>Levels</b></p> <p>Eng Coolant Lvl Engine Oil Level Fuel Level Ext Tank Fuel Lvl</p>	

**Table 5: Digital Input System Events**

### CONFIGURING DIGITAL INPUTS FOR SCADA DATA LINK

When a Digital Input is configured for SCADA Data Link, the state of the input will be placed into the appropriate MODBUS register. No alarms or warnings will be generated by the EMCP. To configure a Digital Input for SCADA Data Link, go through the following menu options:

AT THE MAIN MENU, scroll down  TO CONFIGURE

Press **OK KEY** 



SCROLL DOWN  to inputs & outputs

Press **OK KEY** 



Alternately, access to **THE INPUTS & OUTPUTS** submenu is accessible from **ALL SETPOINTS**.

Press **OK KEY**  to access **DIGITAL INPUTS**

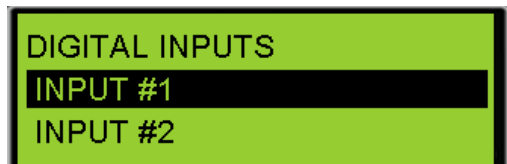

Select the **DIGITAL INPUT** that you want to program

Press the **OK KEY** 

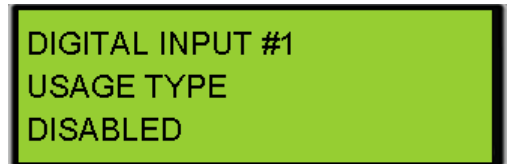

Press the **OK KEY**  to highlight the current configuration (**DISABLED, STATUS, SYSTEM EVENT, OR SCADA**).



Scroll DOWN  to **SCADA DATA LINK**

Press the **OK KEY** 



Scroll DOWN  to **ACTIVE STATE**

Press the **OK KEY**  to highlight the current **ACTIVE STATE**.



Select the **ACTIVE STATE** that you want to program

Press the **OK KEY** 



For information on reading the status of Digital Inputs via MODBUS, please refer to the SCADA documentation.

## DISABLING DIGITAL INPUTS

To disable a Digital Input, go through the following menu options:

AT THE MAIN MENU, scroll down  TO CONFIGURE



Press the OK KEY 

SCROLL DOWN  to INPUTS & OUTPUTS



Press the OK KEY 

Alternately, access to THE INPUTS & OUTPUTS submenu is accessible from ALL SETPOINTS.

Press the OK KEY  to access DIGITAL INPUTS.

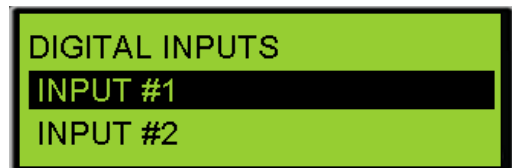

Select the DIGITAL INPUT that you want to program

Press the OK KEY 

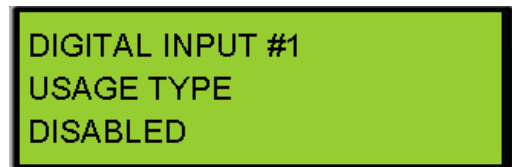

Press the OK KEY  to highlight the current configuration (DISABLED, STATUS, SYSTEM EVENT, OR SCADA).

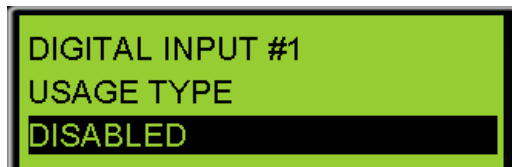

Scroll DOWN  to DISABLED

Press the OK KEY 

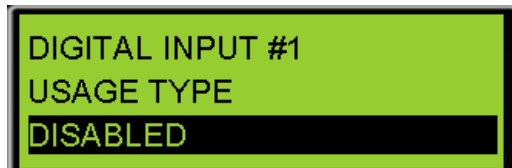

**Note:** If a Digital Input is set to **Disabled**, then any faults or events on that input will not be broadcast or annunciated on the network.

## 8.2 PROGRAMMING DIGITAL INPUTS USING THE CAT SERVICE TOOL

The EMCP 4 Digital Inputs can be configured using the Cat Service Tool. The key to programming them is to program the setpoints related to each input in order from top to bottom. To program an input, do the following steps:

1. Connect to the EMCP 4 using the Cat Service Tool as stated in Chapter 4.2.
2. Select Digital Inputs on the left.

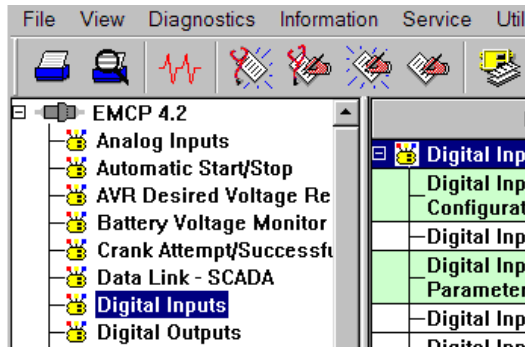

3. Determine which input is to be configured. For example, all of the setpoints for Digital Input #1 have the text "#1" in their name.

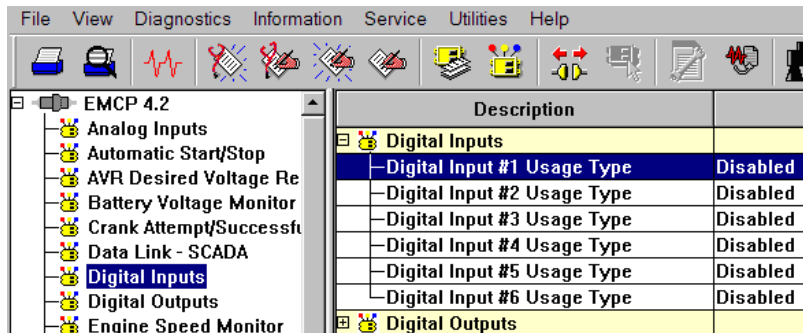

4. Next follow the steps below according to which Usage Type is desired.

## CONFIGURING DIGITAL INPUTS FOR STATUS PARAMETER

1. Double click the Digital Input #N Usage type to change this value to Command/Status Parameter from the drop down menu. Click the OK button to program.

**Change Parameter Value** [?] [X]

Parameter Name: Digital Input #1 Usage Type

Current Value: Command/Status Parameter

New Value: System Event  
**Command/Status Parameter**  
 Data Link  
 Disabled  
 System Event

Please select one of the

OK Cancel

2. The Digital Input #N Command/Status Parameter Data Identification and Active State Configuration parameters will now be visible in the right pane.

Description	Value
<b>Digital Inputs</b>	
Digital Input #1 Active State Configuration	High
Digital Input #1 Usage Type	Command/Status Parameter
Digital Input #1 Command/Status Parameter Data Identification	Lower Voltage

3. Configure the Active State Configuration setpoint according to your wiring – either active High or active Low. Click the OK button to program.

**Change Parameter Value** [?] [X]

Parameter Name: Digital Input #1 Active State Configuration

Current Value: High

New Value: High  
**High**  
 Low

Please select one of the listed values for this parameter.

OK Cancel

4. Double click the Configure the Command/Status Parameter Data Identification setpoint to change this value from the drop down menu. Click the OK button to program.

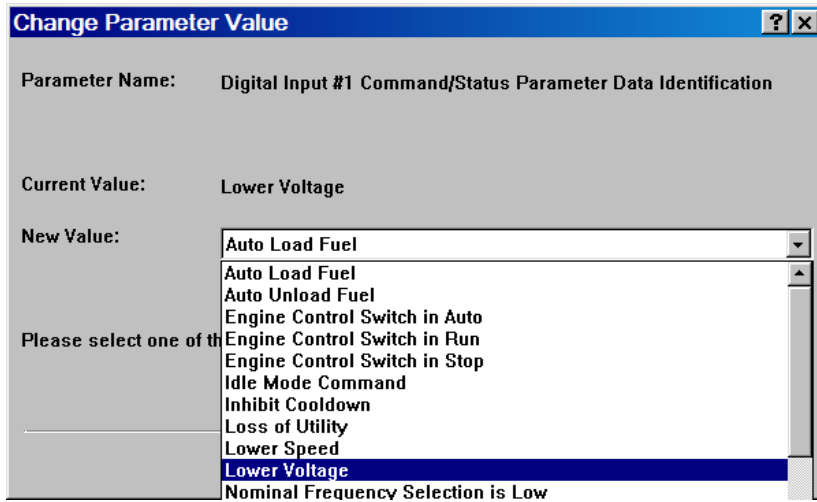

See Table 4 in Chapter 8.1 for a complete list of possible Status Parameter Data Identifications.

### CONFIGURING DIGITAL INPUTS FOR SYSTEM EVENTS

1. Double click the Digital Input #N Usage type to change this value to System Event from the drop down menu. Click the OK button to program.

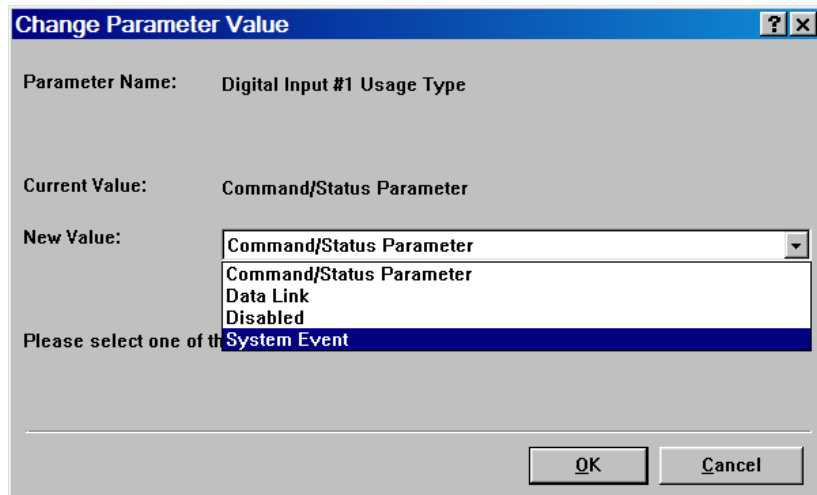

- The Event Input Function #N Event Notification Delay Time, Suspect Parameter Number (SPN), Failure Mode Identifier (FMI) and Active State Configuration parameters will now be visible in the right pane.

Description	Value
 <b>Digital Inputs</b>	
Digital Input #1 Active State Configuration	High
Digital Input #1 Usage Type	System Event
Event Input Function #1 Event Notification Delay Time	10 Sec
Event Input Function #1 Suspect Parameter Number	Custom Event
Event Input Function #1 Failure Mode Identifier	Condition Exists

- Double click the Event Input Function #N Event Notification Delay Time setpoint to change this value. Click the OK button to program.

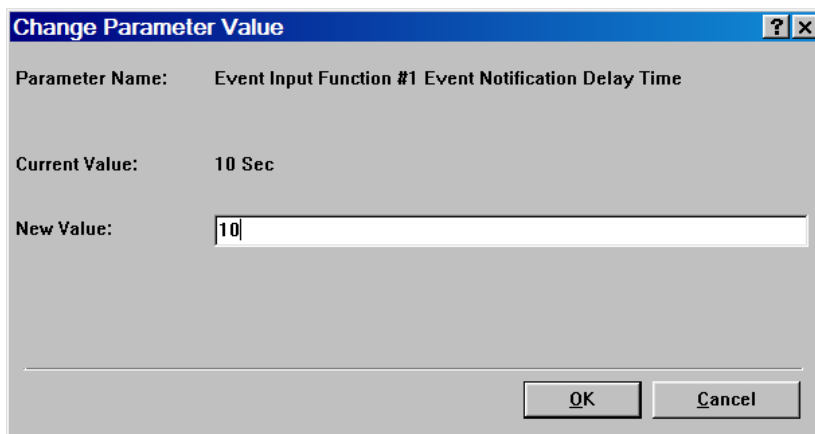

**Change Parameter Value** [?] [X]

Parameter Name: Event Input Function #1 Event Notification Delay Time

Current Value: 10 Sec

New Value:

OK Cancel

- Double click the Event Input Function #N Suspect Parameter Number (SPN) setpoint to change this value from the drop down menu. Click the OK button to program.

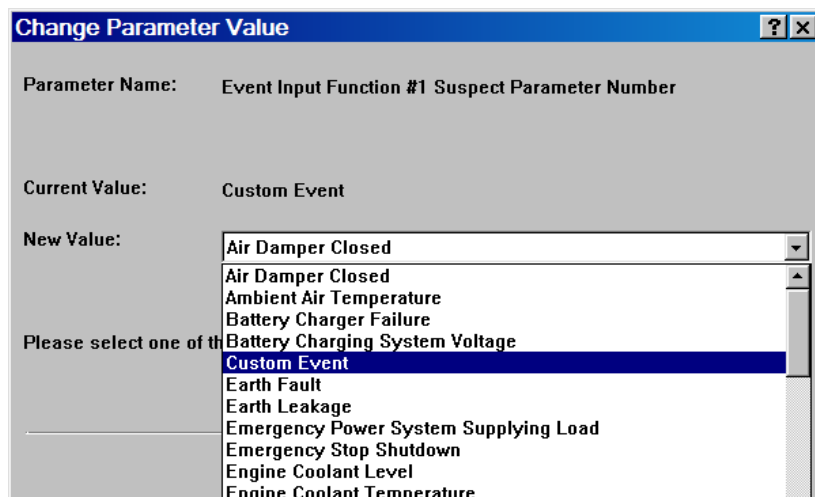

**Change Parameter Value** [?] [X]

Parameter Name: Event Input Function #1 Suspect Parameter Number

Current Value: Custom Event

New Value:

Please select one of the following:

- Air Damper Closed
- Air Damper Closed
- Ambient Air Temperature
- Battery Charger Failure
- Battery Charging System Voltage
- Custom Event**
- Earth Fault
- Earth Leakage
- Emergency Power System Supplying Load
- Emergency Stop Shutdown
- Engine Coolant Level
- Engine Coolant Temperature

5. Double click the Event Input Function #N Failure Mode Identifier (FMI) setpoint to change this value from the drop down menu. Click the OK button to program.

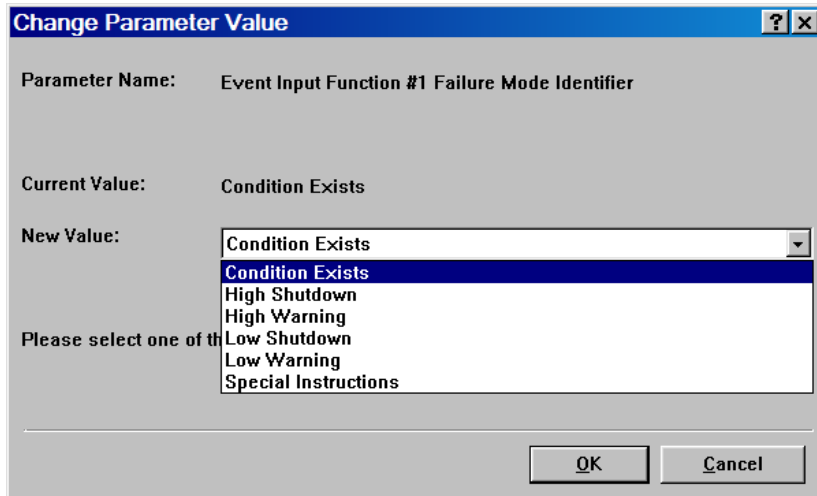

6. Configure the Active State Configuration setpoint according to your wiring – either active High or active Low. Click the OK button to program.

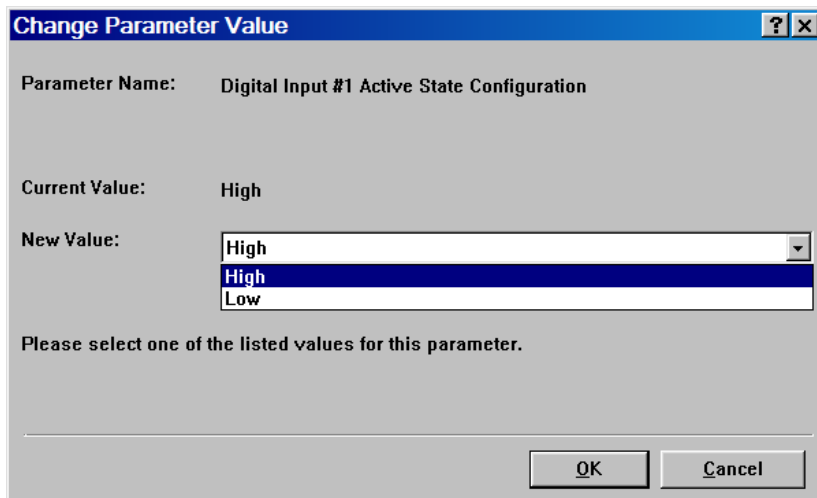

7. Once the input is set with an SPN and FMI, the Event Response Configuration may have to be checked. For information on Event Response Configurations and how to program them, see Chapter 5.2.

Not all SPN and FMI combinations are valid. Table 6 indicates which FMIs are valid for which SPNs. If a combination other than one indicated with a “y” in the table above is configured, the event will not trigger any response by the EMCP 4. The EMCP 4 may not give the option of an invalid FMI for a given SPN. In Cat ET, there is no restriction on the SPN/FMI combination. An invalid combination in Cat ET will result in an “Out of Range” error.

Category	Suspect Parameter Number	Failure Mode Identifier Valid Options				Status
		High Shutdown	Low Shutdown	High Warning	Low Warning	
Pressures	Engine Oil Pressure		y		y	y*
	Gas Pressure	y	y	y	y	
Temperatures	Engine Coolant Temperature	y		y	y	
	Engine Oil Temperature	y	y	y	y	y*
	Exhaust Temperature	y	y	y	y	
	Generator Rear Bearing Temperature	y	y	y	y	
	Generator Winding #1 Temperature	y		y		
Levels	Engine Coolant Level	y	y	y	y	
	Engine Oil Level	y	y	y	y	
	Fuel Level	y	y	y	y	
	External Tank Fuel Level	y	y	y	y	
Others	Air Damper Closed					y
	Battery Charging System Voltage				y	
	Battery Charger Failure					y
	Custom Event (see note below)					y
	Earth Fault					y
	Earth Leakage					y
	Emrg Stop Switch					y*
	EPS Supply Load					y
	Fuel Leak					y
	Gen Bkr Closed					y
	Gen Bkr Open					y
	Generator Current	y	y	y	y	
	Generator Power		y	y	y	
In Man Chrg Comb					y	

**Table 6: Event Input Function SPN and FMI Options**

\*This status is FMI 14 (Special Instruction), not FMI 31 (Condition Exists).

**Note:** For Custom Events, each input can only trigger the custom event number that matches the Digital Input number (Digital Input #1 can only activate Custom Event #1, etc).

## CONFIGURING DIGITAL INPUTS FOR SCADA DATA LINK

1. Double click the Digital Input #N Usage type to change this value to Data Link from the drop down menu. Click the OK button to program.

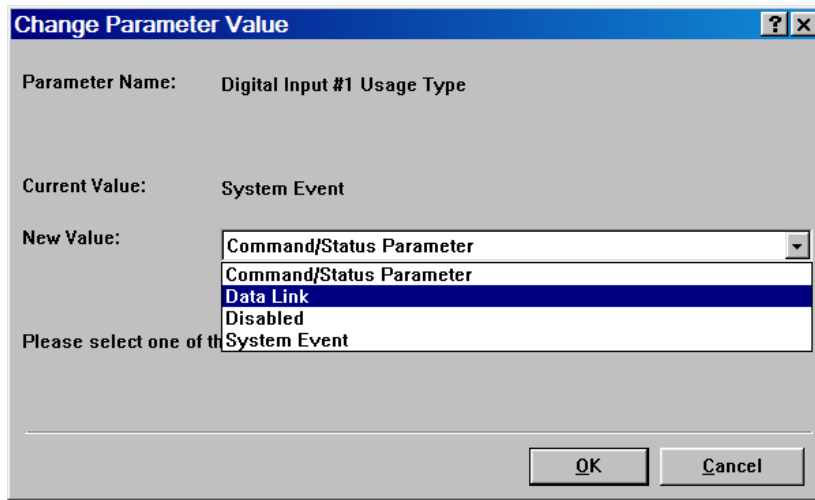

## DISABLING DIGITAL INPUTS

1. Double click the Digital Input #N Usage type to change this value to Disabled from the drop down menu. Click the OK button to program.

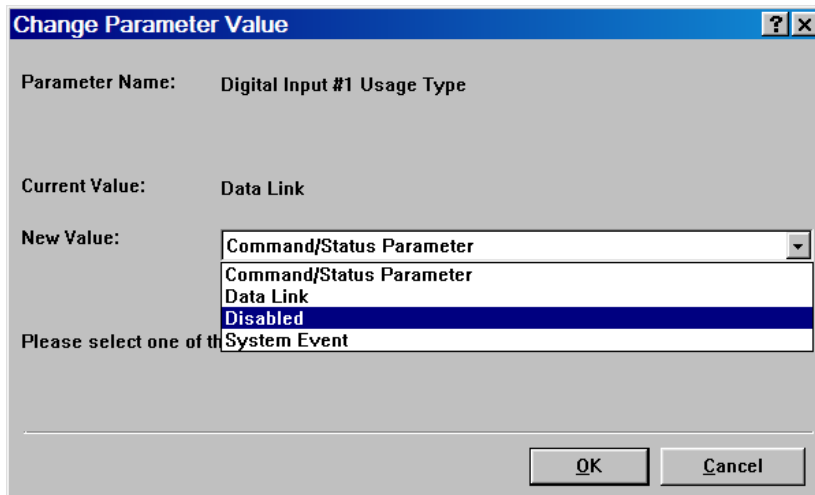

---

## 9 ANALOG INPUTS

The EMCP 4.1 and 4.2 support three 2-wire (plus shield) Analog Inputs. None of these inputs are dedicated to specific functions. These are individually selectable as either Voltage or Resistive Sender inputs for interface to senders, customer signals, etc. The modes of operation are described below:

- Voltage mode: 0-5 Volts with software-selectable sub-ranges (see Table 9 in Chapter 9.3). The input impedance is a minimum of 10k Ohms and a maximum of 1M Ohms. The Analog Input return signals must be tied to battery negative external to the controller.
- Resistive Sender (VDO) Mode: 5-2000 Ohms with software-selectable nonlinear maps. It has 1% or 0.5 Ohms accuracy, whichever is worse. The Analog Input return signals must be tied to battery negative external to the controller.

The Analog Inputs have a 5V common non-isolated power supply capable of supplying up to 100mA of current, and has overload protection. This supply is to be used to provide power to sensors if required by the source power pin and Analog Input returns. The negative side of this supply is battery negative.

See Electrical Connections Chapter 3.5 for illustrations on how to connect the sensors to the control.

Analog Inputs programmed to monitor pressures should be wired to sensors that read gauge, not absolute pressure, unless absolute pressure is desired.

For Analog Inputs, the data range can be positive or negative, but Event thresholds are only positive. Therefore, to prevent nuisance alarms for low warnings, disable the Event Response Configuration if data is acceptable to be negative (see Chapter 5.2).

The first and second Analog Inputs are configured by default for non-electronic engines to monitor engine oil pressure and engine coolant temperature, respectively, and are protected by Level 3 security. The third Analog Input is protected at Level 2 security. For help on programming the Level 3 password prior to running this procedure, see Chapter 6 Security. Alternately, the Cat Service Tool can be used to program these setpoints.

**Note:** If the Analog Inputs are set to **DISABLED**, then any sensor faults or events will not be broadcast or annunciated on the network.

**Note:** If more than one Analog Input is configured for the same physical quantity (i.e. the setpoint Analog Input Data Identification matches between two Analog Inputs), then the higher numbered Analog Input value will be displayed on the Engine Overview screen. For example, if both Analog Input #2 and Analog Input #3 are configured for oil temperature, but the sensor is connected only to Analog Input #2 (and Analog Input #3 is left open), a display of \*\*\*\* diagnostic will result. The Engine Overview screen will display the value from Analog Input #3. Warnings and Shutdowns will be monitored for both Analog Inputs. **When troubleshooting inputs, always make sure to check for configuration conflicts!**

The Analog Inputs are not used for electronic engines that use ADEM™ A3, A4 or newer, engine ECM. On these engines, the engine oil pressure sensor and the engine coolant temperature sensors are wired to the engine ECM and not to the generator set control. In order to receive the sensor information from the data link instead of from sensors wired into the EMCP 4, the setpoints Engine Oil Pressure Sensor Configuration and Engine Coolant Temperature Sensor Configuration must be set to Data Link. If they are not set this way, the sensor values on the Engine Overview screen on the EMCP 4 display will show \*\*\*\* (asterisks).

**Note:** Improper configuration of these inputs can cause a false event to be triggered, or cause an event to not be triggered when desired. If a user disables an input without including other external protection, or disables the annunciation of an enabled input, detection will not be available. If a spare input is enabled, but not wired to a sensor, a false event may occur.

The programming of the Analog Inputs starts by selecting a “Usage Type“. The rest of the programming is dependent upon what Usage Type is selected. Figure 19 summarizes the paths possible for Programming an Analog Input.

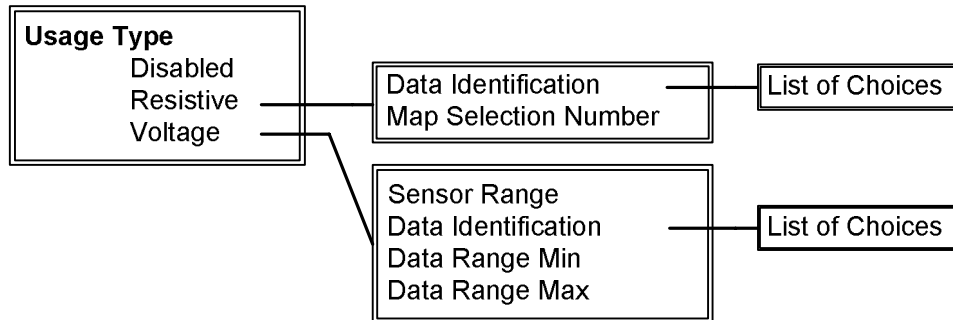

**Figure 19: Analog Input Programming Paths**

## 9.1 PROGRAMMING ANALOG INPUTS USING THE DISPLAY

The steps to configure the Analog Inputs for each of the Usage Types are described below. Level 3 security is required for Analog Inputs #1 and #2. Level 2 security is required for Analog Input #3.

### VIEWING THE CURRENT ANALOG INPUT STATUS

To view the current status of an Analog Input, go through the following menu options:

AT THE MAIN MENU, scroll DOWN  TO VIEW

Press the OK KEY 

Scroll DOWN  to I/O STATUS

Press the OK KEY 

Scroll DOWN  to ANALOG INPUTS

Press the OK KEY 

Scroll DOWN  to choose the ANALOG INPUT desired.

Press the OK KEY 

The programmed Data Identification of the selected Analog Input is shown.

Scroll DOWN  to view the remaining parameters for this input (including the actual value seen on the input).



MAIN MENU

VIEW

CONTROL



VIEW

AC OVERVIEW

I/O STATUS



I/O STATUS

DIGITAL OUTPUTS

ANALOG INPUTS



ANALOG INPUTS

INPUT #1

INPUT #2



ANALOG INPUT #1

DATA IDENTIFICATION

CUSTOM PARAM

### CONFIGURING ANALOG INPUTS FOR RESISTIVE MODE

To configure an Analog Input for Resistive Mode, go through the following menu options:

AT THE MAIN MENU, scroll down  to CONFIGURE

Press the OK KEY 



SCROLL DOWN  to INPUTS & OUTPUTS

Press the OK KEY 

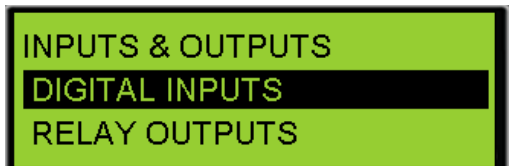

SCROLL DOWN  to ANALOG INPUTS

Press the OK KEY 



Alternately, access to THE INPUTS & OUTPUTS submenu is accessible from ALL SETPOINTS.

Select the ANALOG INPUT that you want to program

Press the OK KEY 



Press the OK KEY  to highlight the current configuration (DISABLED, RESISTIVE, OR VOLTAGE).

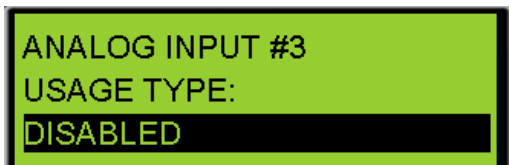

Scroll DOWN  to RESISTIVE

Press the OK KEY 

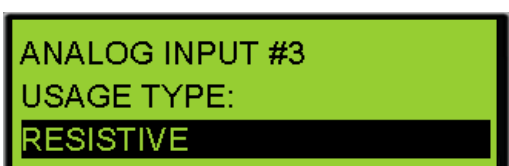

Scroll DOWN  to DATA IDENTIFICATION

Press the OK KEY  to change the current DATA IDENTIFICATION.

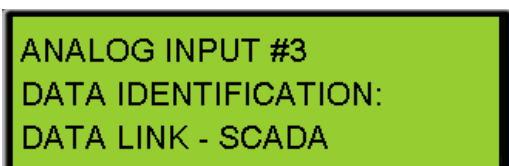

Select the DATA IDENTIFICATION that you want to program

Press the OK KEY 



Scroll **DOWN**  to **MAP SELECTION NUMBER**

Press the **OK KEY**  to change the current **MAP SELECTION NUMBER**.

Select the **MAP SELECTION NUMBER** that you want to program

Press the **OK KEY** .

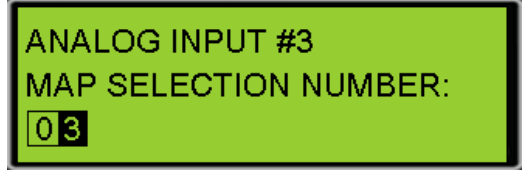
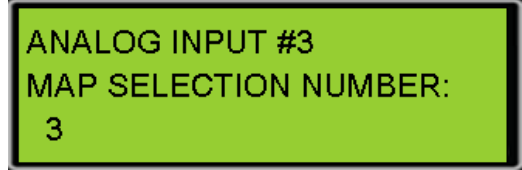

The Data Identification will remain the same when switching between Resistive or Voltage.

Any Analog Input can be configured for any one of the Data Identification parameters in Table 7:

Engine Oil Pres	Urea Level
Eng Coolant Temp	Custom Parameters
Engine Oil Temp	Data Link – SCADA (EMCP 4.2 only)
Engine Fuel Level	Engine Speed
Ext Tank Fuel Level	Gen Voltage

**Table 7: Analog Input Data Identifications**

The Sensor Codes correspond to sensor maps as defined in Chapter 9.3.

### CONFIGURING ANALOG INPUTS FOR VOLTAGE MODE

To configure an Analog Input for Voltage Mode, go through the following menu options:

AT THE MAIN MENU, scroll down  to CONFIGURE

Press the OK KEY 

SCROLL DOWN  to INPUTS & OUTPUTS

Press the OK KEY 

SCROLL DOWN  to ANALOG INPUTS

Press the OK KEY 

Alternately, access to THE INPUTS & OUTPUTS submenu is accessible from ALL SETPOINTS.

Select the ANALOG INPUT that you want to program

Press the OK KEY 

Press the OK KEY  to highlight the current configuration (DISABLED, RESISTIVE, OR VOLTAGE).

Scroll DOWN  to VOLTAGE

Press the OK KEY 

Scroll DOWN  to SENSOR RANGE

Press the OK KEY  to change the current SENSOR RANGE.

Select the SENSOR RANGE that you want to program

Press the OK KEY 

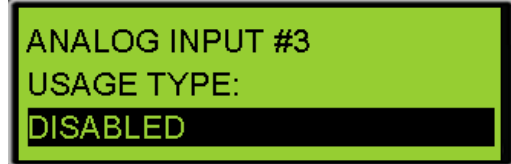
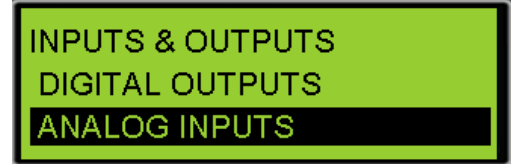
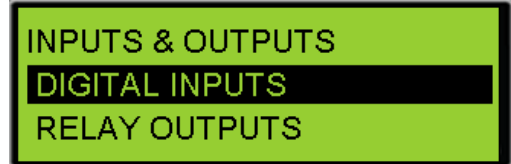

Scroll **DOWN**  to **DATA IDENTIFICATION**

Press the **OK KEY**  to change the current **DATA IDENTIFICATION**.

Select the **STATUS PARAMETER** that you want to program

Press the **OK KEY** 

Scroll **DOWN**  to **DATA RANGE MIN**

Press the **OK KEY**  to change the current **DATA RANGE MIN**.

Select the **DATA RANGE MIN** that you want to program

Press the **OK KEY** 

For Analog Inputs, the data range can be positive or negative, but Event thresholds are only positive. Therefore, to prevent nuisance alarms for low warnings, disable the Event Response Configuration if data is acceptable to be negative (see Chapter 5.2).

Scroll **DOWN**  to **DATA RANGE MAX**

Press the **OK KEY**  to change the current **DATA RANGE MAX**.

Select the **DATA RANGE MAX** that you want to program

Press the **OK KEY** 

ANALOG INPUT #3  
DATA IDENTIFICATION:  
ENG COOLANT TEMP

ANALOG INPUT #3  
DATA IDENTIFICATION:  
ENGINE OIL TEMP

ANALOG INPUT #3  
DATA RANGE MIN:  
-0.00° C

ANALOG INPUT #3  
DATA RANGE MIN:  
- 00 000 . 00

ANALOG INPUT #3  
DATA RANGE MAX:  
100.00° C

ANALOG INPUT #3  
DATA RANGE MAX:  
+ 00 100 . 00

The Data Identification list is the same whether Signal Type is Resistive or Voltage.

Any Analog Input can be configured for any one of the Data Identification parameters in Table 7.

### DISABLING ANALOG INPUTS

To Disable an Analog Input, go through the following menu options:

AT THE MAIN MENU, scroll down  to CONFIGURE

Press the OK KEY 

SCROLL DOWN  to INPUTS & OUTPUTS

Press the OK KEY 

SCROLL DOWN  to ANALOG INPUTS

Press the OK KEY 

Alternately, access to THE INPUTS & OUTPUTS submenu is accessible from ALL SETPOINTS.

Select the ANALOG INPUT that you want to program

Press the OK KEY 

Press the OK KEY  to highlight the current configuration (DISABLED, RESISTIVE, OR VOLTAGE).

Scroll DOWN  to DISABLED

Press the OK KEY 

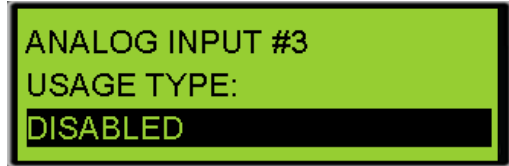
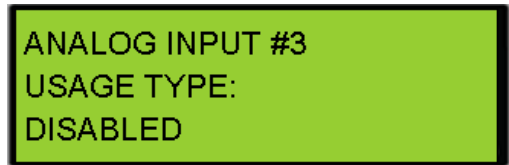
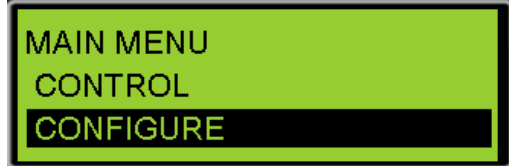

### 9.2 PROGRAMMING ANALOG INPUTS USING THE CAT SERVICE TOOL

The EMCP 4 Analog Inputs can be configured using the Cat Service Tool. The key to programming them is to program the setpoints related to each input in order from top to bottom. To program an Analog Input, do the following steps:

1. Connect to the EMCP 4 using the Cat Service Tool as stated in Chapter 4.2.
  
2. Select Analog Inputs on the left.

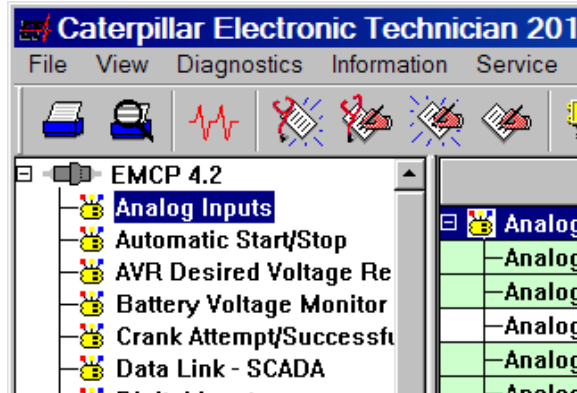

- Determine which input is to be configured. For example, all of the setpoints for Analog Input #1 have the text “#1” in their name.

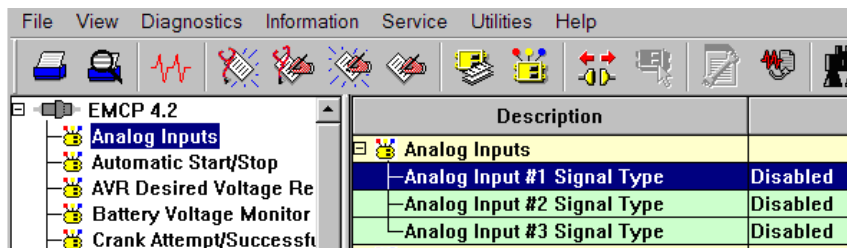

- Next follow the steps below according to which Usage Type is desired.

### CONFIGURING ANALOG INPUTS FOR RESISTIVE MODE

The EMCP 4 supports resistive sender maps, which are nonlinear maps representing the transfer function of the resistive sender. Once an Analog Input is configured as a Resistive input type, a map must be selected.

- Double click the Analog Input #N Usage type to change this value to Resistive Sender from the drop down menu. Click the OK button to program.

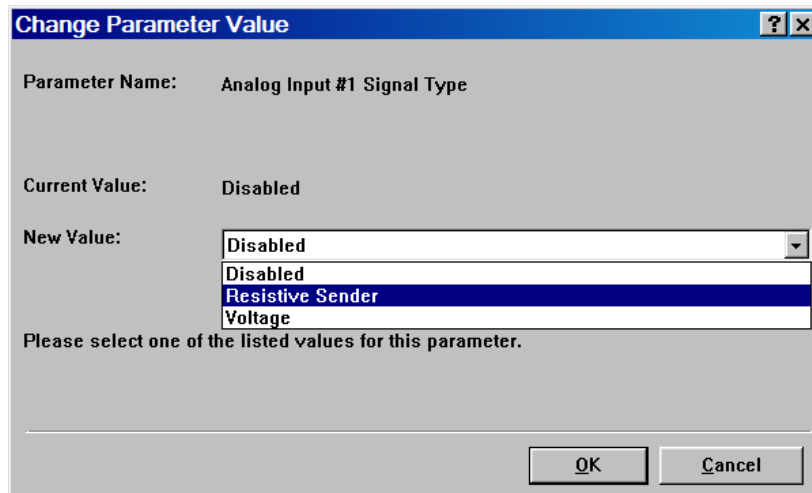

- The Analog Input #N Configuration Code and Data Identification parameters will now be visible in the right pane.

Description	Value
 <b>Analog Inputs</b>	
—Analog Input #1 Signal Type	Resistive Sender
—Analog Input #1 Configuration Code	Map #3
—Analog Input #1 Data Identification	Data Link Only

- Double click the Configuration Code setpoint to change this value from the drop down menu. Click the OK button to program.

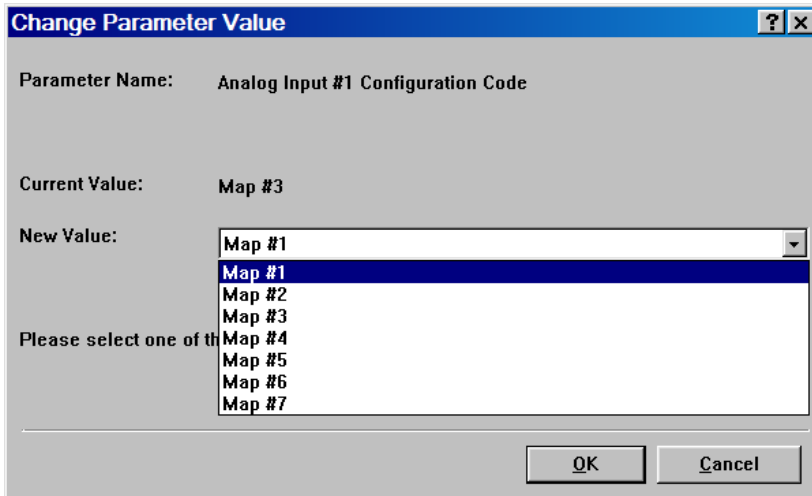

- Double click the Data Identification setpoint to change this value from the drop down menu. Click the OK button to program.

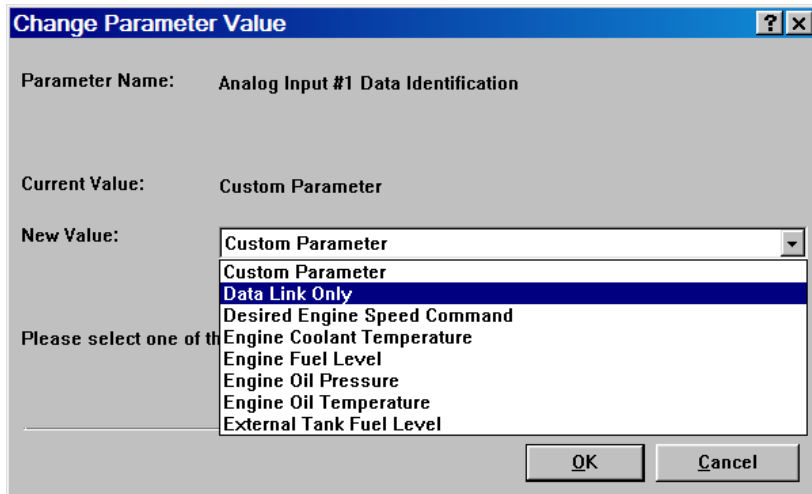

Based on whether or not the selected option supports events, the list of setpoints shown will adjust accordingly. If the selected option does not support events, then the configuration is complete.

- If the selected option does support events, then continue and configure the event thresholds and delays. The Analog Input #N Threshold and Delay Time parameters will now be visible in the right pane.

Description	Value
Analog Inputs	
—Analog Input #1 Signal Type	Resistive Sender
—Analog Input #1 Configuration Code	Map #1
—Analog Input #1 Data Identification	Custom Parameter
—Analog Input #1 High Warning Event Threshold	80
—Analog Input #1 High Warning Event Delay Time	0 Sec
—Analog Input #1 High Shutdown Event Threshold	84
—Analog Input #1 High Shutdown Event Delay Time	0 Sec
—Analog Input #1 Low Warning Event Threshold	20
—Analog Input #1 Low Warning Event Delay Time	0 Sec
—Analog Input #1 Low Shutdown Event Threshold	16
—Analog Input #1 Low Shutdown Event Delay Time	0 Sec

Table 8 lists the options and which, if any, events they support. Not all SPN and FMI combinations are valid. Table 8 indicates which FMIs are valid for which SPNs. If a combination other than one indicated with a “y” in the table above is configured, the event will not trigger any response by the EMCP 4. The EMCP 4 may not give the option of an invalid FMI for a given SPN. In Cat ET, there is no restriction on the SPN/FMI combination. An invalid combination in Cat ET will result in an “Out of Range” error.

Suspect Parameter Number	Failure Mode Identifier Valid Options			
	High Shutdown	Low Shutdown	High Warning	Low Warning
Engine Oil Pressure		y		y
Engine Coolant Temperature	y		y	y
Engine Oil Temperature	y	y	y	y
Fuel Level	y	y	y	y
External Tank Fuel Level	y	y	y	y
Gen Volt Control				
Urea Tank Level				
Custom Event (see note below)	y	y	y	y
Data Link Only				
Desired Engine Speed Command				

**Table 8: Event Input Function SPN and FMI Options**

**Note:** For Custom Events, each input can only trigger the custom event number that matches the Analog Input number (Analog Input #1 can only activate Custom Event #1, etc.).

- Configure each of these setpoints by double clicking each one and typing a new value. Click the OK button to program.

**Change Parameter Value** [?] [X]

Parameter Name: Analog Input #1 High Warning Event Delay Time

Current Value: 0 Sec

New Value: 5

[OK] [Cancel]

**Note:** The units for the event thresholds are not shown. For pressures, the units are always kPa. For temperatures, they are always degrees Celsius. For levels, they are always percent. For the custom parameter type, they are unitless. The range for custom parameters is defined by the selected sensor map if programmed for resistive.

### CONFIGURING ANALOG INPUTS FOR VOLTAGE MODE

The EMCP 4 supports linear voltage senders, which are senders whose output voltage varies linearly with the change in a physical measurement. Once the Analog Input is configured as a Voltage Input type, the linear mapping must be defined by entering the sensor voltage range and the corresponding minimum and maximum physical measurement range.

- Double click the Analog Input #N Usage type to change this value to Voltage from the drop down menu. Click the OK button to program.

**Change Parameter Value** [?] [X]

Parameter Name: Analog Input #1 Signal Type

Current Value: Voltage

New Value: Disabled  
Disabled  
Resistive Sender  
Voltage

Please select one of the listed values for this parameter.

[OK] [Cancel]

- The Analog Input #N Signal Range, Data Identification, and Minimum and Maximum Data Range parameters will now be visible in the right pane.

Description	Value
Analog Inputs	
— Analog Input #1 Signal Type	Voltage
— Analog Input #1 Signal Range	0 to 5 V
— Analog Input #1 Data Identification	Data Link Only
— Analog Input #1 Minimum Data Range	0.060
— Analog Input #1 Maximum Data Range	0.100

- Double click the Signal Range setpoint to change this value from the drop down menu to match the range supported by your sensor (or the next larger range). See Chapter 9.3 for what to do if the desired sensor's range is not supported. Click the OK button to program.

**Change Parameter Value** [?] [X]

Parameter Name: Analog Input #1 Signal Range

Current Value: 0 to 5 V

New Value: 

- 0 to 5 V
- 0.5 to 4.5 V
- 1 to 5 V

Please select one of the listed values for this parameter.

OK Cancel

- Double click the Data Identification setpoint to change this value from the drop down menu. Click the OK button to program.

**Change Parameter Value** [?] [X]

Parameter Name: Analog Input #1 Data Identification

Current Value: Custom Parameter

New Value: 

- Custom Parameter
- Data Link Only
- Desired Engine Speed Command
- Engine Coolant Temperature
- Engine Fuel Level
- Engine Oil Pressure
- Engine Oil Temperature
- External Tank Fuel Level

Please select one of th

OK Cancel

- Based on whether or not the selected option supports events, the list of setpoints shown will adjust accordingly. Table 8 lists the options and which, if any, events they support.

- Configure each of the Minimum and Maximum Data Range setpoints by double clicking each setpoint and typing a new value. Click the OK button to program.

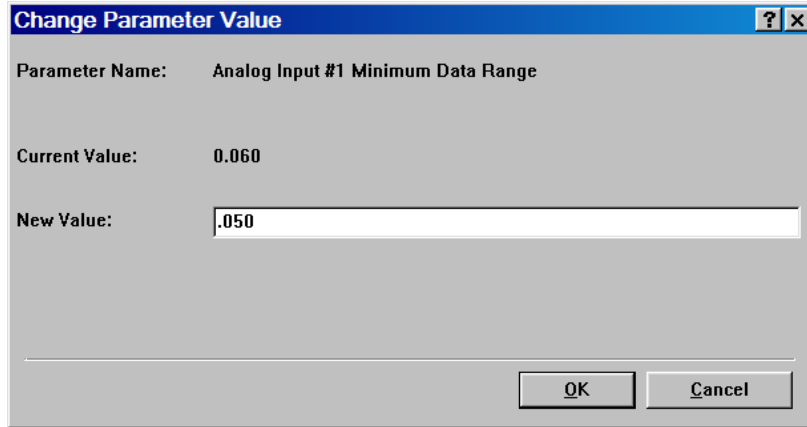

For Analog Inputs, the data range can be positive or negative, but Event thresholds are only positive. Therefore, to prevent nuisance alarms for low warnings, disable the Event Response Configuration if data is acceptable to be negative (see Chapter 5.2).

- If the selected Data Identification does support events, then continue and configure the event thresholds and delays. The Analog Input #N Threshold and Delay Time parameters will be visible in the right pane.

Description	Value
Analog Inputs	
—Analog Input #1 Signal Type	Voltage
—Analog Input #1 Signal Range	0 to 5 V
—Analog Input #1 Data Identification	Custom Parameter
—Analog Input #1 Minimum Data Range	0.060
—Analog Input #1 Maximum Data Range	0.100
—Analog Input #1 High Warning Event Threshold	80
—Analog Input #1 High Warning Event Delay Time	0 Sec
—Analog Input #1 High Shutdown Event Threshold	84
—Analog Input #1 High Shutdown Event Delay Time	0 Sec
—Analog Input #1 Low Warning Event Threshold	20
—Analog Input #1 Low Warning Event Delay Time	0 Sec
—Analog Input #1 Low Shutdown Event Threshold	16
—Analog Input #1 Low Shutdown Event Delay Time	0 Sec

- Configure each of these setpoints by double clicking each one and typing a new value. Click the OK button to program.

The screenshot shows a dialog box titled "Change Parameter Value" with a blue header bar containing a question mark icon and a close button. The dialog has a light gray background. It contains the following text and controls:

- Parameter Name:** Analog Input #1 High Warning Event Delay Time
- Current Value:** 0 Sec
- New Value:** A text input field containing the number "5".
- At the bottom right, there are two buttons: "OK" and "Cancel".

**Note:** The units for the event thresholds are not shown. For pressures, the units are always kPa. For temperatures, they are always degrees Celsius. For levels, they are always percent. For the custom parameter type, they are unitless. The range for custom parameters is defined by the selected sensor map.

## DISABLING ANALOG INPUTS

- Double click the Analog Input #N Usage type to change this value to Disabled from the drop down menu. Click the OK button to program.

The screenshot shows a dialog box titled "Change Parameter Value" with a blue header bar containing a question mark icon and a close button. The dialog has a light gray background. It contains the following text and controls:

- Parameter Name:** Analog Input #1 Signal Type
- Current Value:** Resistive Sender
- New Value:** A dropdown menu with "Disabled" selected.
- Below the dropdown, the text "Please select one of the listed values for this parameter." is displayed.
- At the bottom right, there are two buttons: "OK" and "Cancel".

**Note:** If the Analog Inputs are set to Disabled, then any sensor faults or events will not be broadcast or annunciated on the network.

### 9.3 ANALOG INPUT MAPS

Resistive senders can use nonlinear sensor maps. These maps are not available for Voltage or Current modes. Maps are predefined in the software flash file, and can be selected by the customer. The Analog Inputs are capable of reading resistance from ~5 ohms.

The following maps are predefined:

**Analog Input Map #1  
Engine Oil Pressure  
Map #1**

Ohms	kPa
5.15625	0
10.234375	0
20.859375	50
31.328125	100
41.5625	150
51.5625	200
61.328125	250
70.9375	300
80.390625	350
89.53125	400
98.59375	450
107.34375	500
115.9375	550
124.296875	600
132.5	650
140.46875	700
148.203125	750
155.78125	800
163.125	850
170.234375	900
177.1875	950
183.90625	1000

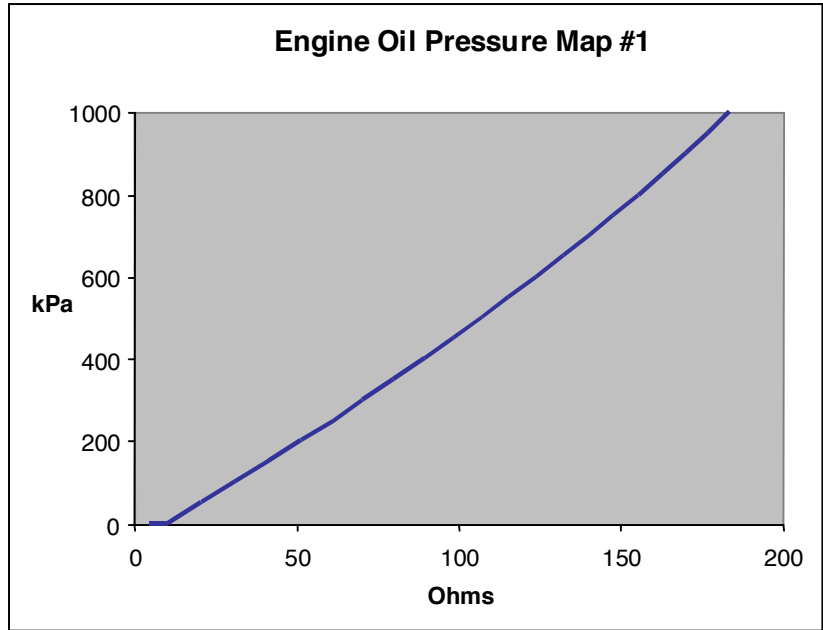

**Analog Input Map #2****Engine Oil Pressure**

Ohms	kPa
0	0
8	0
9	45
9.79280164	50
97.53483284	1000

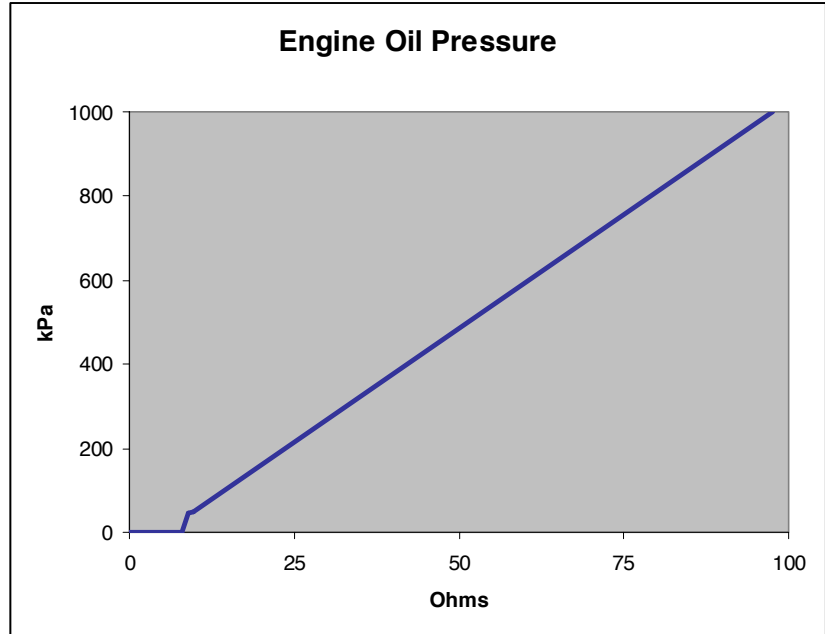

**Analog Input Map #3  
Engine Coolant Temp.  
Map #1**

Ohms	Degrees C
10.96	150
12.833486	143
15.097968	136
17.873487	129
20.7791	123
24.243433	117
28.351106	111
33.4	105
39.575632	99
46.921325	93
56.092114	87
67.912203	81
82.36	75
103.630957	68
129.551496	61
168.012845	54
221.883488	47
291.46	40
387.47457	33
520.636327	26
676.95	20
890.619054	14
1182.891558	8
1575.596421	2
2249.4	-5

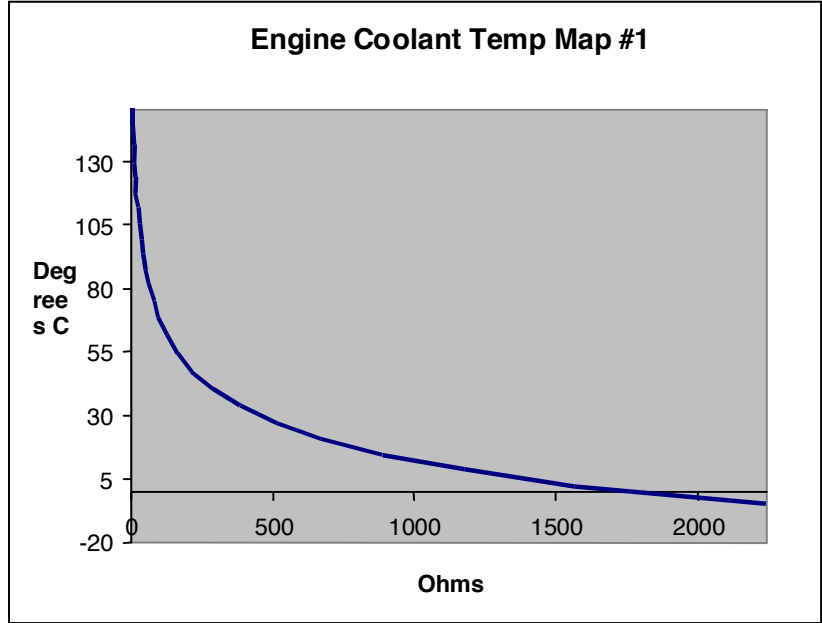

**Analog Input Map #4**  
**Engine Coolant Temp.**  
**Map #2**

Ohms	Degrees C
2442	-48
1518	-39
968.9	-30
633.6	-21
423.9	-12
289.7	-3
201.9	6
148.8	14
111.2	22
84.2	30
64.5	38
50	46
39.2	54
31	62
24.8	70
20	78
16.3	86
13.3	94
11.03	102
9.18	110
7.7	118
6.5	126
5.53	134
4.72	142
4.06	150

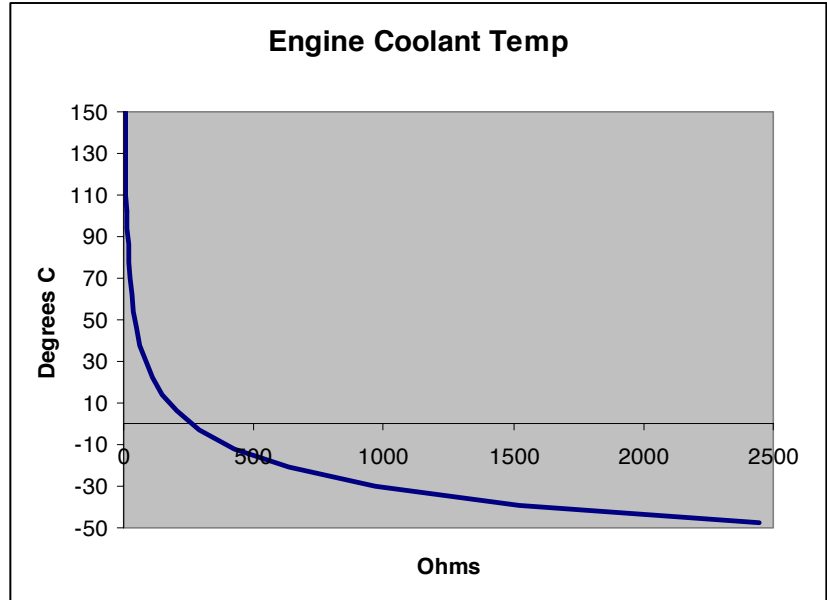

**Analog Input Map #5**

**Oil Temp**

<b>Ohms</b>	<b>Degrees C</b>
10.24	180
11.915106	172
13.936869	164
16.397384	156
18.986869	149
22.021713	142
25.7	135
30.17989	128
35.6296	121
42.512367	114
51.202344	107
61.92	100
75.805097	93
93.55964	86
115.597997	79
145.179619	72
184.72	65
238.039938	58
309.945216	51
408.742034	44
546.580666	37
773.706899	29
1114.873752	21
1640.337776	13
2473.6	5

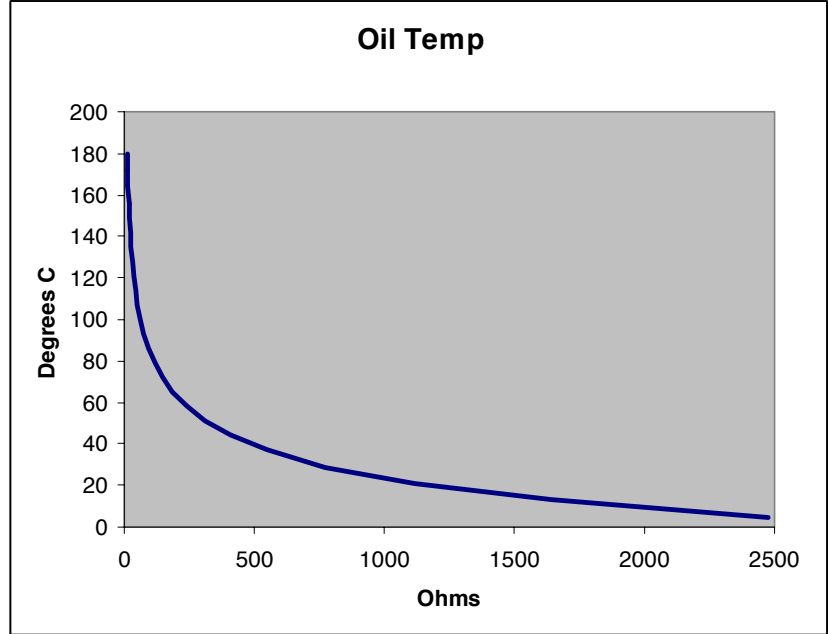

**Analog Input Map #6  
Engine Coolant Temp  
Map #3**

<b>Ohms</b>	<b>Degrees C</b>
6.875	150
8.203125	142
9.84375	134
11.5625	127
13.75	120
16.328125	113
19.609375	106
23.671875	99
28.828125	92
35.390625	85
43.671875	78
54.453125	71
68.515625	64
87.109375	57
111.796875	50
145.078125	43
190.46875	36
253.359375	29
341.484375	22
467.03125	15
648.828125	8
916.640625	1
1318.515625	-6
2046.5625	-14

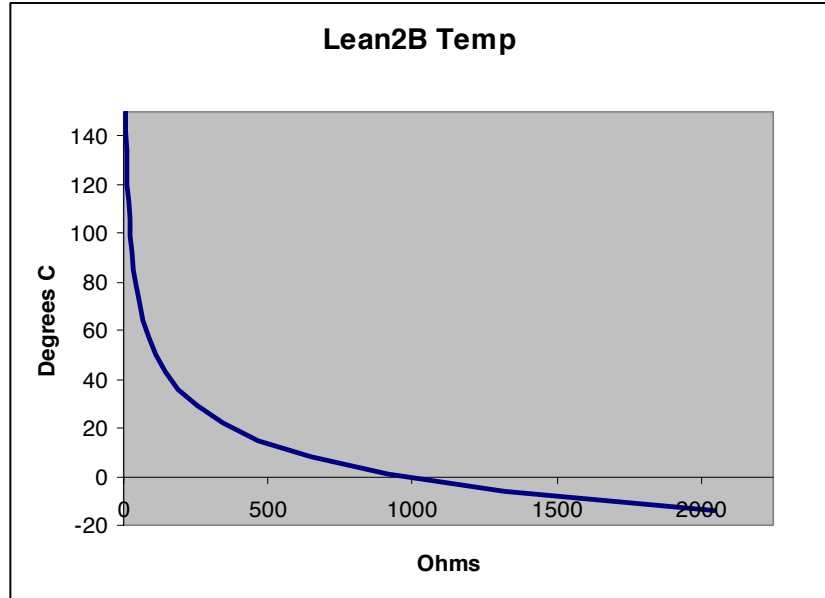

**Analog Input Map #7**

**Fozmula Fuel Level**

Ohms	%
10.5	0
35.6	25
60.2	50
85.2	75
103.2	100

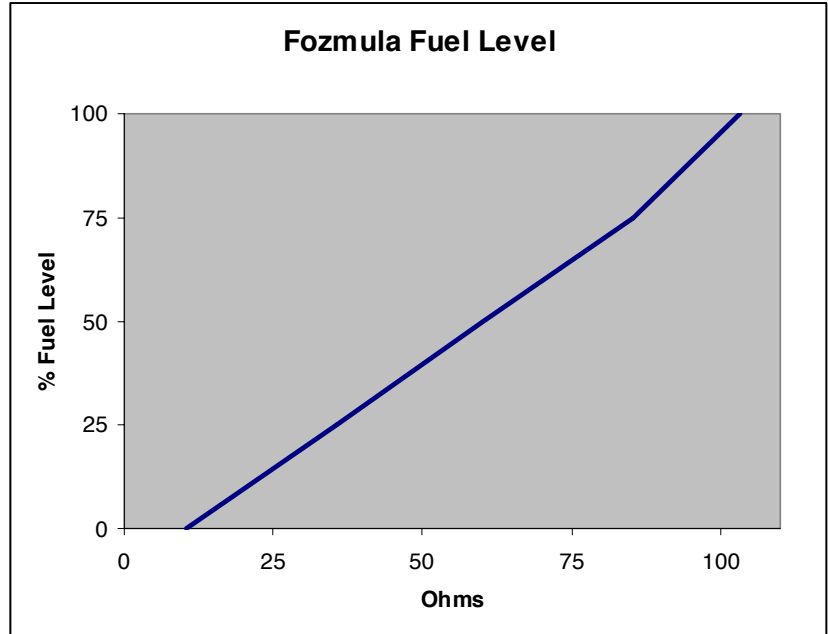

**Analog Input Map #8**

**Linear Level**

Ohms	%
0	0
2000	100

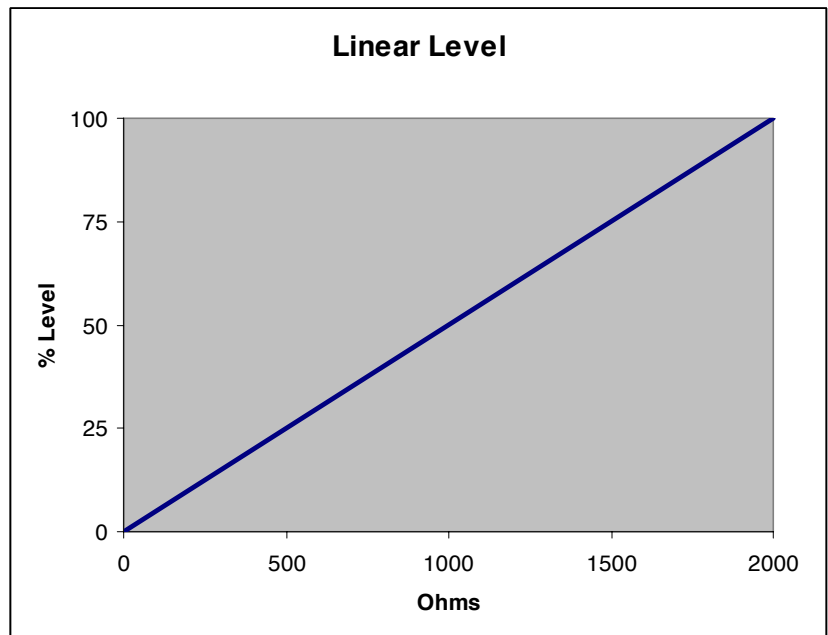

**Analog Input Map #9**

**Power Module Tank Level #1**

Ohms	%
10.46875	0
35.625	25
60.234375	50
85.234375	75
103.203125	100

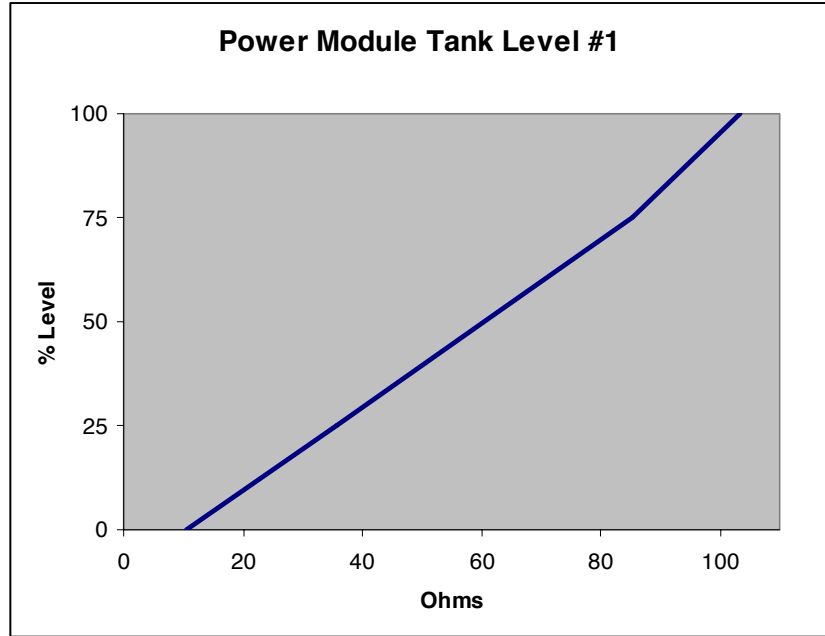

**Analog Input Map #10**

**Power Module Tank Level #2**

Ohms	%
10	100
135	100
348.203125	0
500	0

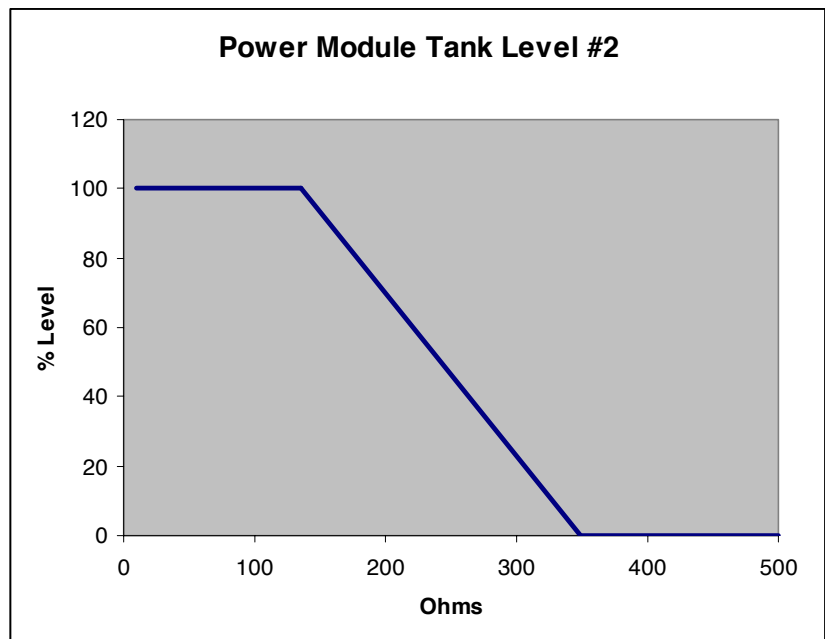

For EMCP 4.1 and 4.2, voltage senders can be configured within the ranges in Table 9:

<u>Voltage Sender Ranges</u>
0 to 5V
1 to 5V
0.5 to 4.5V

**Table 9: Analog Input Ranges**

Analog Input data ranges can be defined with positive and negative values, but Event thresholds are only programmable as positive values. Therefore, to prevent nuisance alarms for low warnings when using negative numbers for data ranges, the Event Response Configuration can be disabled, if input data is acceptable to be negative.

## WARNINGS AND SHUTDOWNS

Each of these inputs can be configured to have **HIGH WARNINGS**, **LOW WARNINGS**, **HIGH SHUTDOWNS** and **LOW SHUTDOWNS** with configurable thresholds. Any value below the bottom point on the map or above the highest point on the map will raise a corresponding diagnostic event. Also, all of the events associated with the Analog Inputs have programmable time delays. Low Idle Oil Pressure setpoints are also available under the Engine Oil Monitor area. Information on how to program these thresholds and time delays can be found in Chapter 7, Setpoints.

## UNSUPPORTED ANALOG INPUT SENSOR RANGES

There may be Voltage sensors available that use ranges not explicitly supported by the EMCP 4. Depending on the situation, there may be different ways to handle this. The following sections give options on how to handle these situations.

### SENSOR RANGE IS SMALLER THAN SETPOINT OPTIONS

If the desired sensor range is smaller than one of the available setpoint options, then extrapolation may be used to support the desired sensor. For example, for a 0-3V temperature sensor reads -30°C to 120°C, the only range that includes all of 0-3V is 0-5V. The 0-5V range should be used. The range between 3V and 5V will simply never be used. To make the data accurate, set the Minimum Data Range to -30°C, and determine the Maximum Data Range mathematically. See Figure 20.

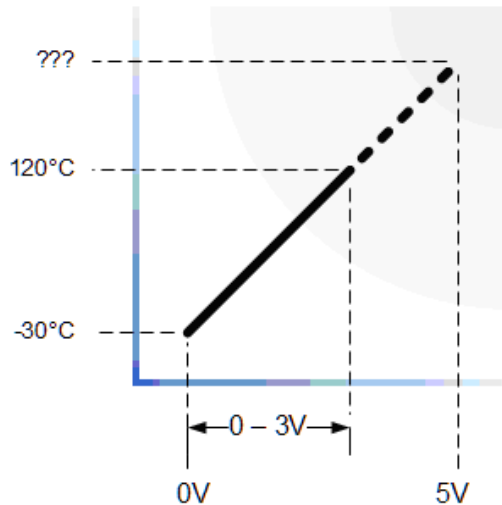

**Figure 20: Mathematical Extrapolation of Maximum Data Range**

The Maximum Data Range can be found graphically or algebraically. In this example, the Maximum Data Range would be defined by the equation of the line after the slope is determined. Since the data rises by 50 degrees for every volt, increasing two volts above the three volt limit requires the maximum range to be 100 degrees above the sensor limit of 120 degrees, or 220 degrees total. See Figure 21.

$$\left[ \frac{[120\text{C} - (-30\text{C})]}{(3\text{V} - 0\text{V})} \right] * (5\text{V}) + (-30\text{C}) = 220\text{C}$$

**Figure 21: Example Calculation for Extrapolation of Maximum Data Range**

### SENSOR RANGE IS LARGER THAN SETPOINT OPTIONS, BUT USABLE RANGE IS NOT

If the desired sensor range is larger than one of the available setpoint options, but the useful range for the sensor is within the supported ranges, then interpolation may be used to support the desired sensor. For example, for a 0-6V temperature sensor that reads -40°C to 500°C, the EMCP 4 will not support the analog voltages higher than 5V. However, as long as the sensor will not exceed 5V, the 0-5V range may be used. To make the data accurate, set the Minimum Data Range to -40°C, and determine the Maximum Data Range mathematically. See Figure 22.

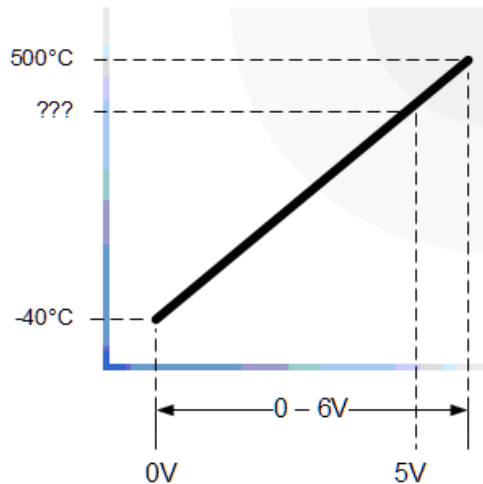

**Figure 22: Mathematical Interpolation of Maximum Data Range**

The Maximum Data Range can be found graphically or algebraically. In this example, the Maximum Data Range would be defined by the equation of the line after the slope is determined. Since the data rises by 90 degrees for every volt, decreasing one volt below the six volt limit requires the maximum range to be 90 degrees below the sensor limit of 500 degrees, or 410 degrees total. See Figure 23.

$$\left[ \frac{[500\text{C} - (-40\text{C})]}{(6\text{V} - 0\text{V})} \right] * (5\text{V}) + (-40\text{C}) = 410\text{C}$$

**Figure 23: Example Calculation for Interpolation of Maximum Data Range**

**SENSOR RANGE IS LARGER THAN SETPOINT OPTIONS, AND USABLE RANGE IS LARGER THAN SETPOINT OPTIONS**

If the desired sensor range is larger than one of the available setpoint options, and the useful range for the sensor is outside of the supported ranges, a third party device is required to convert the signal range into a supported range. See Figure 24.

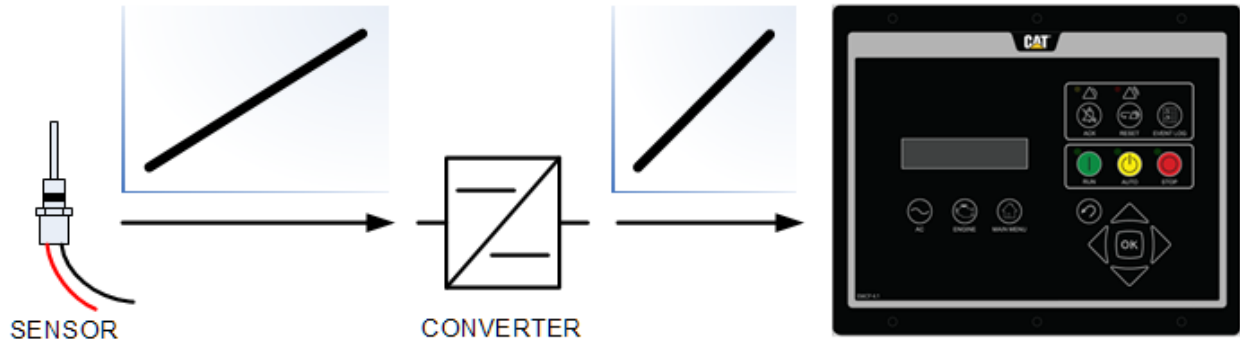

**Figure 24: Signal Conversion of Sensor Range**

## 10 OUTPUTS

The EMCP 4.1 and 4.2 support Relay Outputs capable of 2A resistive at 30V DC. The EMCP 4.1 has six Form A Relay Outputs (normally open) while the EMCP 4.2 has six Form A Relay Outputs and two Form C Relay Outputs (both normally open and normally closed).

The EMCP 4.2 also supports two programmable discrete outputs capable of sinking 300mA per input. These outputs will sink a current to draw down a voltage of up to 30V DC down to Battery (-).

Outputs can be configured by using the EMCP 4 display. For some of the setpoints, LEVEL 2 OR LEVEL 3 ACCESS is required. For information on obtaining Level 2 or Level 3 Access refer to Chapter 6 Security.

Security. This section will assume that the correct Level 2 or Level 3 Access has already been obtained. Alternately, the Cat Service Tool can be used to configure these outputs.

The programming of the Digital and Relay Outputs starts by selecting a "Usage Type". The rest of the programming is dependent upon what Usage Type is selected. Figure 25 summarizes the paths possible for Programming Digital and Relay Outputs.

**Note:** If the Engine Operating State is configured as Hardwired, then Relay Output #1 must be programmed to Starter Motor Relay and Relay Output #2 must be programmed to Fuel Control Relay.

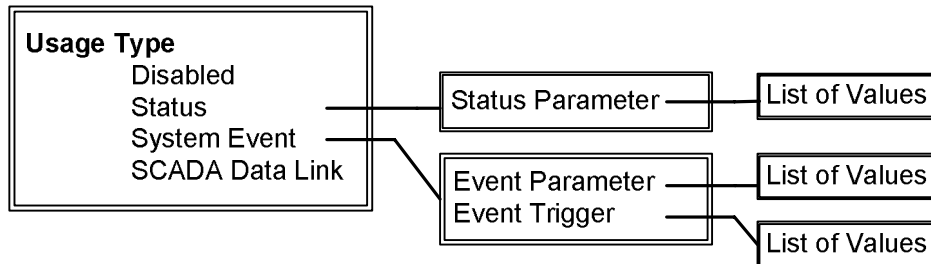

**Figure 25: Digital and Relay Output Programming Paths**

### 10.1 PROGRAMMING OUTPUTS USING THE DISPLAY

For some of the setpoints, LEVEL 2 OR LEVEL 3 ACCESS is required. For information on obtaining Level 2 Access refer to Chapter 6 Security.



This section will assume that Level 2 or Level 3 Access has already been obtained.

#### VIEWING THE CURRENT OUTPUT STATUS

To view the current status of an Output, go through the following menu options:

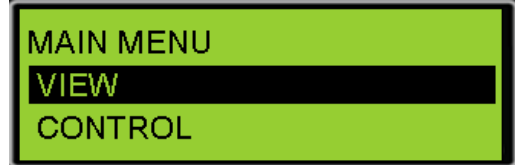
AT THE MAIN MENU, scroll DOWN  TO VIEW  
Press the OK KEY 



Scroll DOWN  to I/O STATUS  
Press the OK KEY 

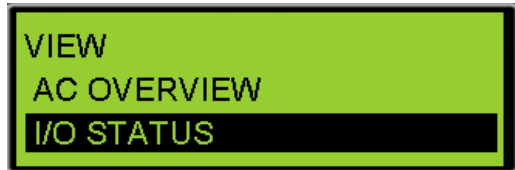

Scroll DOWN  to access RELAY OR DIGITAL OUTPUTS  
Press the OK KEY 



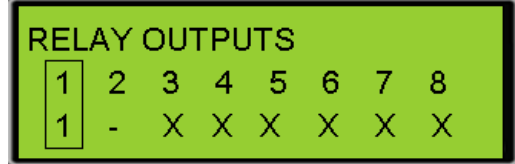

The status of all Relay or Digital Outputs is shown.  
A dash under an output number indicates an output that is programmed, but inactive. A large "X" under an output number indicates an output that is disabled. A number under an output number indicates an output that is programmed and active.

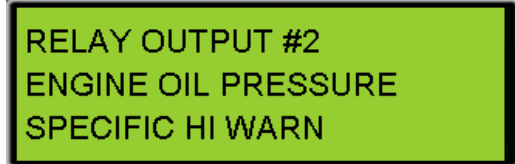

With the LEFT ARROW  or RIGHT ARROW , select the RELAY OR DIGITAL OUTPUT that you want to view, then press the OK KEY .

The programmed Usage Type of the selected relay or Digital Output is shown.



Scroll DOWN  to view the remaining parameters for this output (including physical and logical state).

#### CONFIGURING OUTPUTS FOR STATUS PARAMETERS

Command or Status parameters are used to control specific functions within the control system or to make certain conditions within the system be known.

**Note:** The Fuel Control Relay does not pickup when the Engine Operating State is set to CAN. Engine Start Initiated can be used in Lieu of the Fuel Control Relay for most purposes.

To configure a Digital Output or Relay Output as a Status Parameter, go through the following menu options (substitute Digital Output for Relay Output in the following steps, as needed):

AT THE MAIN MENU, scroll down  TO CONFIGURE

Press the OK KEY 

SCROLL DOWN  TO INPUTS & OUTPUTS

Press the OK KEY 

Alternately, access to **THE INPUTS & OUTPUTS** submenu is accessible from **ALL SETPOINTS**.

SCROLL DOWN  TO RELAY OUTPUTS

Press the OK KEY 

Select the **RELAY OUTPUT** that you want to program

Press the OK KEY 

Press the OK KEY  to highlight the current configuration (**DISABLED, STATUS, SYSTEM EVENT, OR SCADA DATA LINK**).

Scroll DOWN  TO STATUS

Press the OK KEY 

Scroll DOWN  TO STATUS PARAMETER

Press the OK KEY  to highlight the current **STATUS PARAMETER**.

Select the **STATUS PARAMETER** that you want to program

Press the OK KEY 

MAIN MENU  
CONTROL  
CONFIGURE

INPUTS & OUTPUTS  
DIGITAL INPUTS  
RELAY OUTPUTS

INPUTS & OUTPUTS  
DIGITAL INPUTS  
RELAY OUTPUTS

RELAY OUTPUTS  
OUTPUT #1  
OUTPUT #2

RELAY OUTPUT #1  
USAGE TYPE:  
DISABLED

RELAY OUTPUT #1  
USAGE TYPE:  
STATUS

RELAY OUTPUT #1  
STATUS PARAMETER:  
STOP MODE

RELAY OUTPUT #1  
STATUS PARAMETER:  
AUTO MODE

Any Output can be configured for any one of the Status parameters in Table 10:

Run Mode	Common Warning
Auto Mode	Common S/D
Stop Mode	ECU Fault Reset
Pckg Not in Auto	Air Shutoff
Fuel Ctrl Relay*	Prog Cycl Time #2 (EMCP 4.2 only)
Start Mtr Relay	kW Relay Trip #1 (EMCP 4.2 only)
Start Aid	kW Relay Trip #2 (EMCP 4.2 only)
Disable Aux AC	Common Alarm
Crank Alert	Breaker #1 Trip
Engine Start Initiated	Breaker #2 Trip
Engine Started	Reduced Power Off
Rated Speed	Transfer Fuel In
V/Hz Within Limits	Volt Raise Cmnd
Eng in Cooldown	Volt Lower Cmnd
Wait Delay Stop	Speed Raise Cmnd
Horn Control	Speed Lower Cmnd

**Table 10: Output Status List**

\*The Fuel Control Relay does not pickup when the Engine Operating State is set to CAN. Engine Start Initiated can be used in Lieu of the Fuel Control Relay for most purposes.

**Note:** If the Engine State Configuration is configured for Hard Wired, then Relay Output #1 must be programmed for the Status Parameter of Starter Motor Relay and Relay Output #2 must be programmed for Fuel Control Relay

**CONFIGURING OUTPUTS FOR SYSTEM EVENTS**

System Events are used to know when specific conditions are reached and to alert the control system of warning or shutdown conditions. To configure a Relay or Digital Output as a System Event, go through the following menu options (substitute Digital Output for Relay Output in the following steps, as needed):

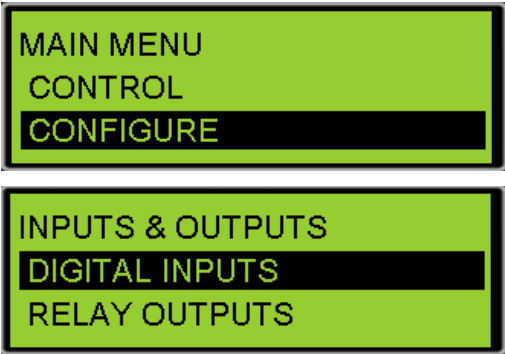
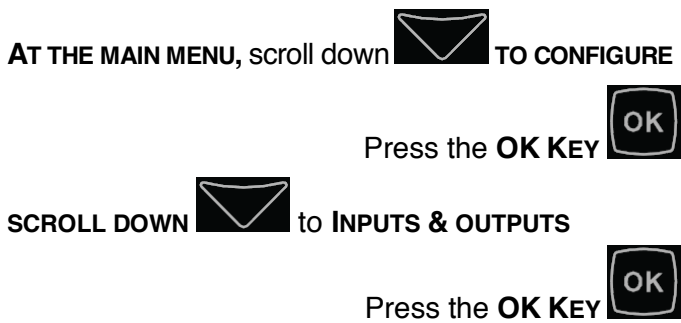

Alternately, access to THE INPUTS & OUTPUTS submenu is accessible from ALL SETPOINTS.

SCROLL DOWN  to RELAY OUTPUTS

Press the OK KEY 





Select the RELAY OUTPUT that you want to program

Press the OK KEY 

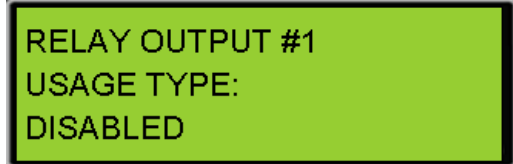

Press the OK KEY  to highlight the current configuration (**DISABLED, STATUS, SYSTEM EVENT, OR SCADA DATA LINK**).



Scroll DOWN  to SYSTEM EVENT

Press the OK KEY 



Scroll DOWN  to EVENT PARAMETER

Press the OK KEY  to edit the current STATUS PARAMETER.

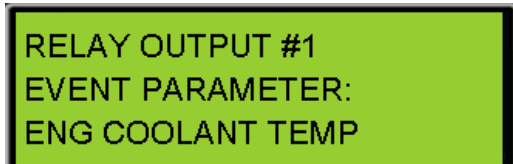

Select the type of EVENT PARAMETER that you want to program (Pressures, Temperatures, Levels, or Others)

Press the OK KEY 



Select the **EVENT PARAMETER** that you want to program

Press the **OK KEY** 



Scroll **DOWN**  to **EVENT TRIGGER**

Press the **OK KEY**  to edit the current **EVENT TRIGGER**.



Select the **EVENT TRIGGER** that you want to program

Press the **OK KEY** 



Any Output can be configured for any one of the System Events in Table 11:

<b>Pressures</b>	<b>Others</b>	<b>Custom Events</b>
Engine Oil Pres Gas Pressure	Any SPN Accessory Dlink (4.2 only) Bat Chg Sys Volt Battery Voltage Emer Stop Switch Eng in Cooldown Eng Fail to Start Engine Speed Ctrl Not in Auto Gen Current Gen Frequency Gen Real Power Gen Voltage Primary Data Link SCADA Data Link (4.2 only) Service Interval Expired Unexpected Eng S/D Earth Fault Earth Leakage Eng Control Fuel Leak Air Dmpr Closed Batt Chrgr Fail Gen Bkr Open Gen Bkr Closed	Dig In #1 Cstm Dig In #2 Cstm Dig In #3 Cstm Dig In #4 Cstm Dig In #5 Cstm Dig In #6 Cstm Analog In #1 Cstm Analog In #2 Cstm Analog In #3 Cstm
<b>Temperatures</b>		
Eng Coolant Temp Engine Oil Temp Exhaust Temp Gen Rear Brg Tmp Gen Windg #1 Tmp		
<b>Levels</b>		
Eng Coolant Lvl Engine Oil Level Fuel Level Ext Tank Fuel Lvl		

**Table 11: Output System Events**

Care must be taken in configuring the correct triggers. Only some of these can be configured for a specific System Event and even if it can be configured, it may not be representative of the system requirements.

### CONFIGURING OUTPUTS FOR SCADA DATA LINK

When an Output is configured for SCADA Data Link, an active state will be sent over MODBUS. No alarms or warnings will be generated by the EMCP. To configure a Relay Digital Output for SCADA Data Link, go through the following menu options (substitute Digital Output for Relay Output in the following steps, as needed):

AT THE MAIN MENU, scroll down  TO CONFIGURE

Press the OK KEY 

SCROLL DOWN  to INPUTS & OUTPUTS

Press the OK KEY 

Alternately, access to THE INPUTS & OUTPUTS submenu is accessible from ALL SETPOINTS.

SCROLL DOWN  to RELAY OUTPUTS

Press the OK KEY 

Select the RELAY OUTPUT that you want to program

Press the OK KEY 

Press the OK KEY  to highlight the current configuration (DISABLED, STATUS, SYSTEM EVENT, OR SCADA DATA LINK).

Scroll DOWN  to SCADA DATA LINK

Press the OK KEY 









### DISABLING OUTPUTS

To disable an Output, go through the following menu options (substitute Digital Output for Relay Output in the following steps, as needed):

AT THE MAIN MENU, scroll down  TO CONFIGURE

Press the OK KEY 



SCROLL DOWN  TO INPUTS & OUTPUTS

Press the OK KEY 



Alternately, access to THE INPUTS & OUTPUTS submenu is accessible from ALL SETPOINTS.

SCROLL DOWN  TO RELAY OUTPUTS

Press the OK KEY 



Select the RELAY OUTPUT that you want to program

Press the OK KEY 

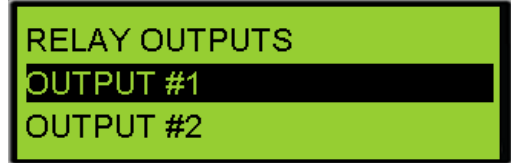

Press the OK KEY  to highlight the current configuration (DISABLED, STATUS, SYSTEM EVENT, OR SCADA DATA LINK).

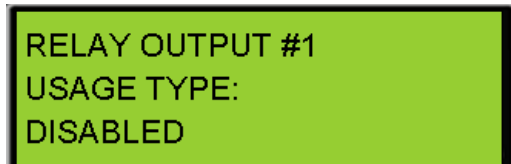

Scroll DOWN  TO DISABLED

Press the OK KEY 

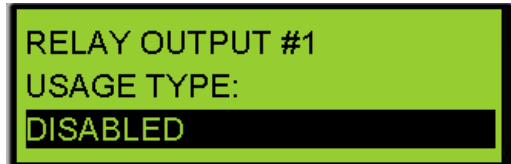

### 10.2 PROGRAMMING OUTPUTS USING THE CAT SERVICE TOOL

The EMCP 4 Outputs can be configured by using the Cat Service Tool. The key to programming them is to program the setpoints related to each input in order from top to bottom. Relay and Digital Outputs follow the same steps. For simplicity, the examples below show Relay Outputs. For Digital Outputs, just substitute Digital Output for Relay Output. To program an Output, do the following steps:

1. Connect to the EMCP 4 using the Cat Service Tool as stated in Chapter 4.2.
2. Select Relay (or Digital Outputs) on the left.

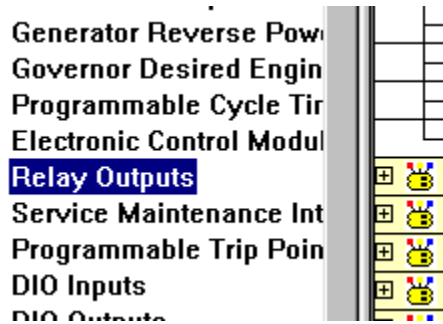

- Determine which output is to be configured. For example, all of the setpoints for Relay Output #1 have the text “#1” in their name.

Level Response Config	Relay Outputs	
Generator AC Monitor	- Relay Output #1 Usage Type	Disabled
Generator AC Power Mon	- Relay Output #2 Usage Type	Disabled
Generator Current Monit	- Relay Output #3 Usage Type	Disabled
Generator Over/Under F	- Relay Output #4 Usage Type	Disabled
Generator Over/Under V	- Relay Output #5 Usage Type	Disabled
Generator Reverse Pow	- Relay Output #6 Usage Type	Disabled
Governor Desired Engin	- Relay Output #7 Usage Type	Disabled
Programmable Cycle Tir	- Relay Output #8 Usage Type	Disabled
Electronic Control Modul	Service Maintenance Interval	

- Next follow the steps below according to which Usage Type is desired.

### CONFIGURING OUTPUTS FOR STATUS PARAMETERS

Command or Status parameters are used to control specific functions within the control system or to make certain conditions within the system be known.

**Note:** The Fuel Control Relay does not pickup when the Engine Operating State is set to CAN. Engine Start Initiated can be used in Lieu of the Fuel Control Relay for most purposes.

To configure an Output as a Command or Status Parameter, go through the following menu options:

1. Double click the Output #N Usage type to change this value to Command/Status Parameter from the drop down menu. Click the OK button to program.

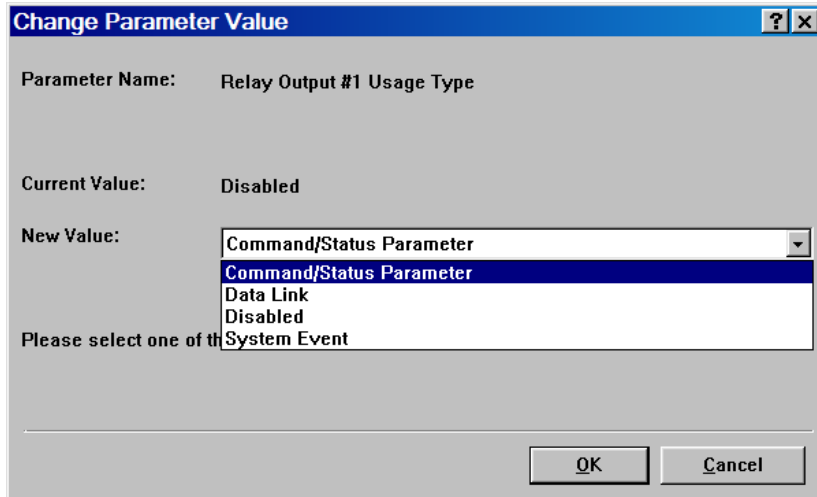

2. The Output #N Command/Status Parameter Data Identification parameter will now be visible in the right pane.

Relay Outputs	
Relay Output #1 Usage Type	Command/Status Parameter
Relay Output #1 Command/Status Parameter Data Identification	Stop Mode

3. Double click the Configure the Command/Status Parameter Data Identification setpoint to change this value from the drop down menu. Click the OK button to program.

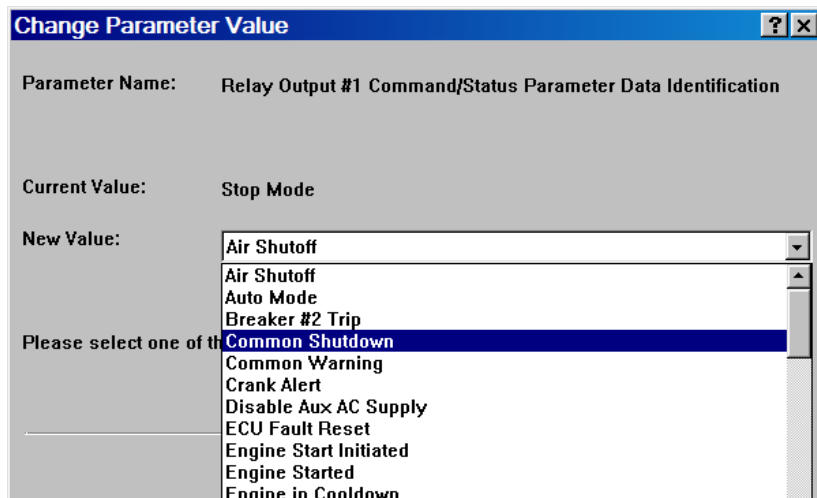

See Table 10 in Chapter 10.1 for a complete list of possible Status Parameter Data Identifications.

### CONFIGURING OUTPUTS FOR SYSTEM EVENTS

System Events are used to know when specific conditions are reached and to alert the control system of warning or shutdown conditions. To configure an Output as a System Event, go through the following menu options:

1. Double click the Output #N Usage type to change this value to System Event from the drop down menu. Click the OK button to program.

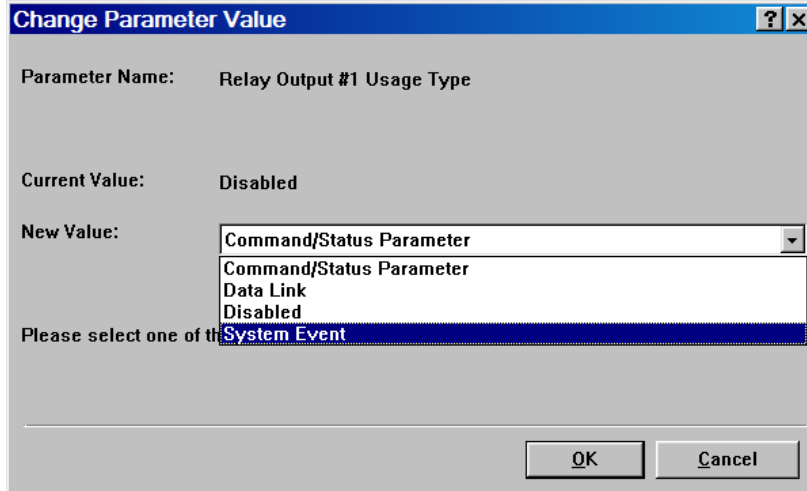

2. The Output #N Suspect Parameter Number (SPN) and Event Trigger Condition parameters will now be visible in the right pane.

Relay Outputs	
Relay Output #1 Usage Type	System Event
Relay Output #1 Event Suspect Parameter Number	Engine Oil Pressure
Relay Output #1 Event Trigger Condition	General Event - Any Shutdown

3. Double click the Output #N Suspect Parameter Number (SPN) setpoint to change this value from the drop down menu. Click the OK button to program.

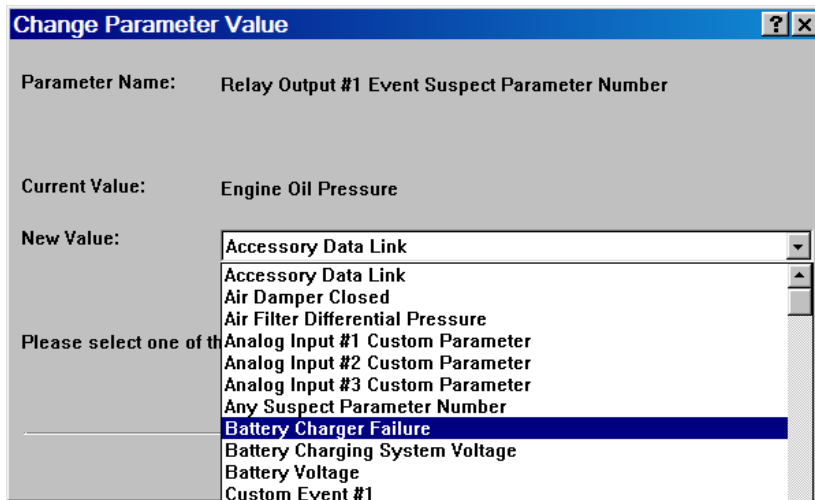

4. Double click the Output #N Event Trigger Condition setpoint to change this value from the drop down menu. Click the OK button to program.

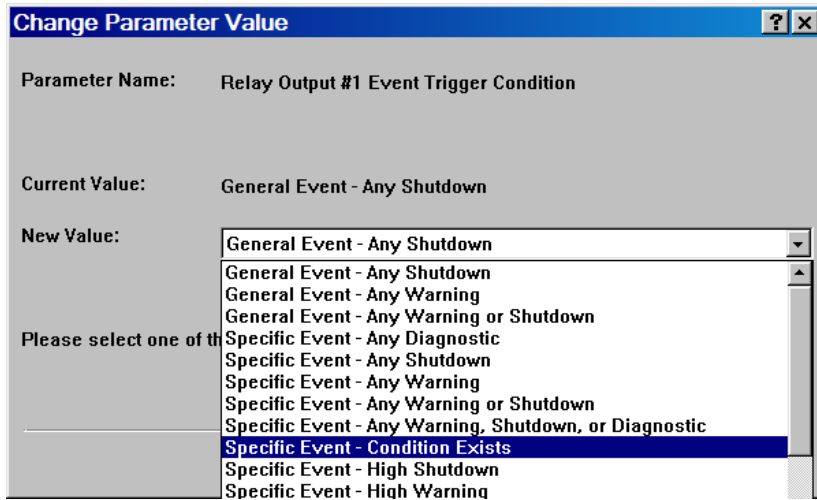

See Table 11 in Chapter 10.1 for a complete list of possible System Events.

### CONFIGURING OUTPUTS FOR SCADA DATA LINK

When an Output is configured for SCADA Data Link, an active state will be sent over MODBUS. No alarms or warnings will be generated by the EMCP. To configure an Output for SCADA Data Link, go through the following menu options:

1. Double click the Output #N Usage type to change this value to Data Link from the drop down menu. Click the OK button to program.

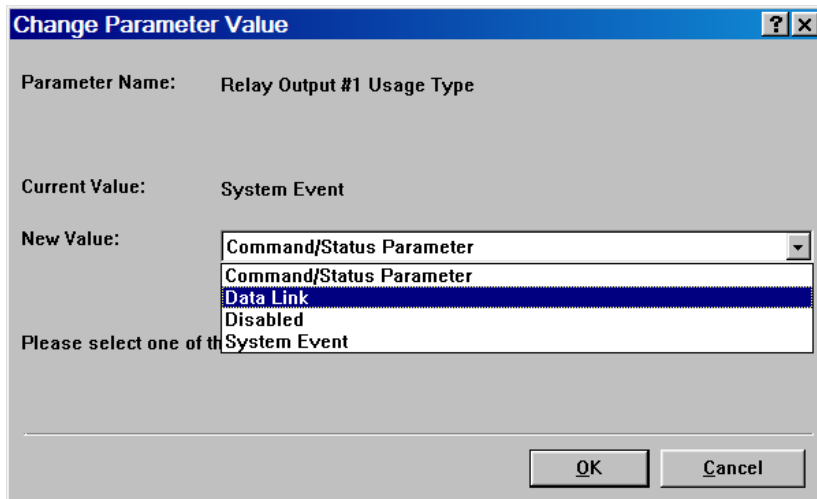

## DISABLING OUTPUTS

To disable an Output, go through the following menu options:

1. Double click the Relay Output #N Usage type to change this value to Disabled from the drop down menu. Click the OK button to program.

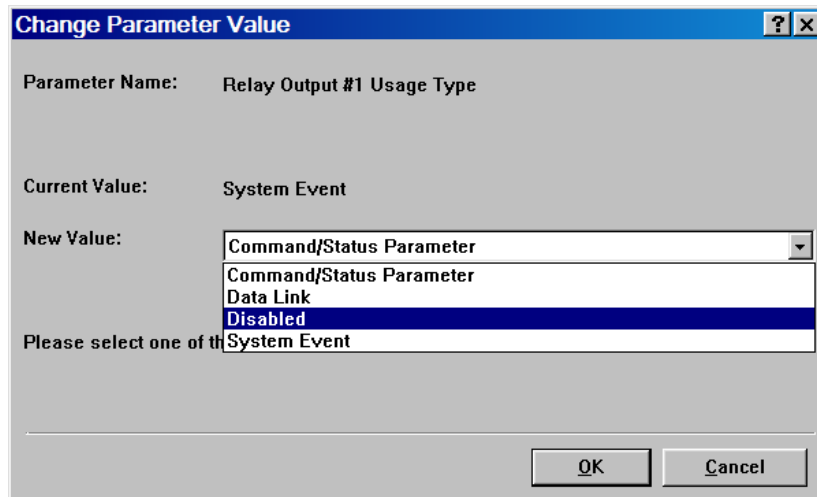

## 11 MODIFIABLE TEXT STRINGS

The EMCP 4 supports the renaming of Custom Events for the event log. This feature is called **MODIFIABLE TEXT STRINGS**. This is useful when an existing SPN and text string do not exist for the required event. These events can be configured and triggered similar to other events. However, these events are unique in that their displayed text strings can be customized via the Cat Service Tool using any character in the supported character set of the EMCP 4 software flash file. Furthermore, the Cat Service Tool has the capability to upload a Modifiable Text Strings configuration file (containing previously saved custom event text strings) from the computer, or download a configuration from the EMCP 4 to the computer.

In order to display a custom text string for an event, the following steps must be taken:

1. One of the Digital Inputs must be configured as a Custom Event with a Failure Mode Identifier of Status (or Condition Exists). For more information on configuring Digital Inputs, see Chapter 8.1.
2. A custom string must be entered, using the Modifiable Text Strings tool in the Cat Service Tool, as described in Chapter 11.2.
3. The language must be set to the customer language, *not* to Technician English.

An example of entering a modifiable text string for Custom Event #1 is given in Figure 26.

Input	Value
<input type="checkbox"/> Display	
<input type="checkbox"/> Event 1 Line 1	BUILDING FIRE DETECTED
<input type="checkbox"/> Event 1 Line 2	FORCED SHUTDOWN
<input type="checkbox"/> Event 2 Line 1	

**Figure 26: Customizing A Text String With the Cat Service Tool**

The EMCP 4 supports one Modifiable text string per Custom Event on each programmable Digital Input.

## 11.1 LANGUAGE SUPPORT

The primary language for the EMCP 4 control will always be Technician English. The user will always be able to revert back to Technician English from the selected language that is supported by the flash file. However, when the EMCP 4 display is viewed in Technician English, the user will not be able to view the custom text strings and will only be able to view the default strings (Custom Event #X) for a given input.

The EMCP 4 has the capability of supporting one flash file containing one secondary language at any particular time. If the user is interested in having a new secondary language, a new flash file to configure the new language must be installed. Therefore, the user is not able to install multiple flash files supporting different languages simultaneously.

The EMCP 4 supports Unicode characters from the English character set, as well as the character set from the local language supported by the file. It is the user's responsibility to install the preferred flash file with the correct language support that will allow the modification of text strings.

The user is also responsible for choosing the appropriate operating system or Unicode text entry system for the chosen language. The Cat Service Tool software accepts input from the PC keyboard settings. If, for example, the PC keyboard setting is for U.S. English, it may be difficult to enter Russian (or other non-English) characters.

Different language software support different sets of characters. Therefore, Modifiable Text String configuration files created in one language will not become translated if new language software is flashed into the EMCP 4. The original text string will still show as originally entered.

## 11.2 PROGRAMMING MODIFIABLE TEXT STRINGS USING THE CAT SERVICE TOOL

To configure a Modifiable Text String using the Cat Service Tool, go through the following menu options:

1. Connect the EMCP to the Cat Electronic Technician as described in Chapter 4.2.

**Note:** The Service Tool must be connected to CAN 1.

2. Select "Modifiable Strings" under "Service" from the choices at the top of the software screen.

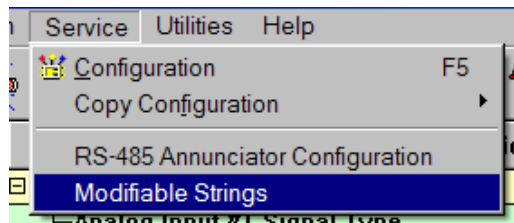

3. The “Modifiable Strings” screen will appear.

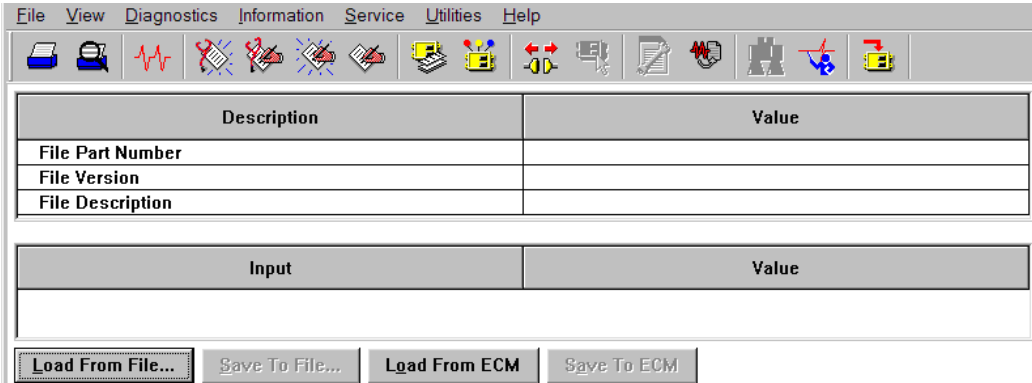

4. In order to load the existing text string file from the ECM, click the “Load From ECM” button on the bottom of the screen.

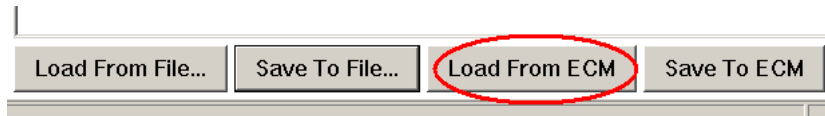

5. The stored strings, if any, will appear. For first time configuration, the strings will be blank.

Input	Value
EMCP	
-Custom Event 1 Line 1	
-Custom Event 1 Line 2	
-Custom Event 2 Line 1	
-Custom Event 2 Line 2	
-Custom Event 3 Line 1	
-Custom Event 3 Line 2	
-Custom Event 4 Line 1	
-Custom Event 4 Line 2	
-Custom Event 5 Line 1	
-Custom Event 5 Line 2	
-Custom Event 6 Line 1	
-Custom Event 6 Line 2	
-Custom Event 7 Line 1	
-Custom Event 7 Line 2	
-Custom Event 8 Line 1	
-Custom Event 8 Line 2	

- Click in the Value column next to the event to be modified. Type the desired text string. The Modifiable Text String is considered a pair of text strings, and the user has the option of customizing the pair of text strings. The second line has less available space, because the event log index is also displayed on that line.

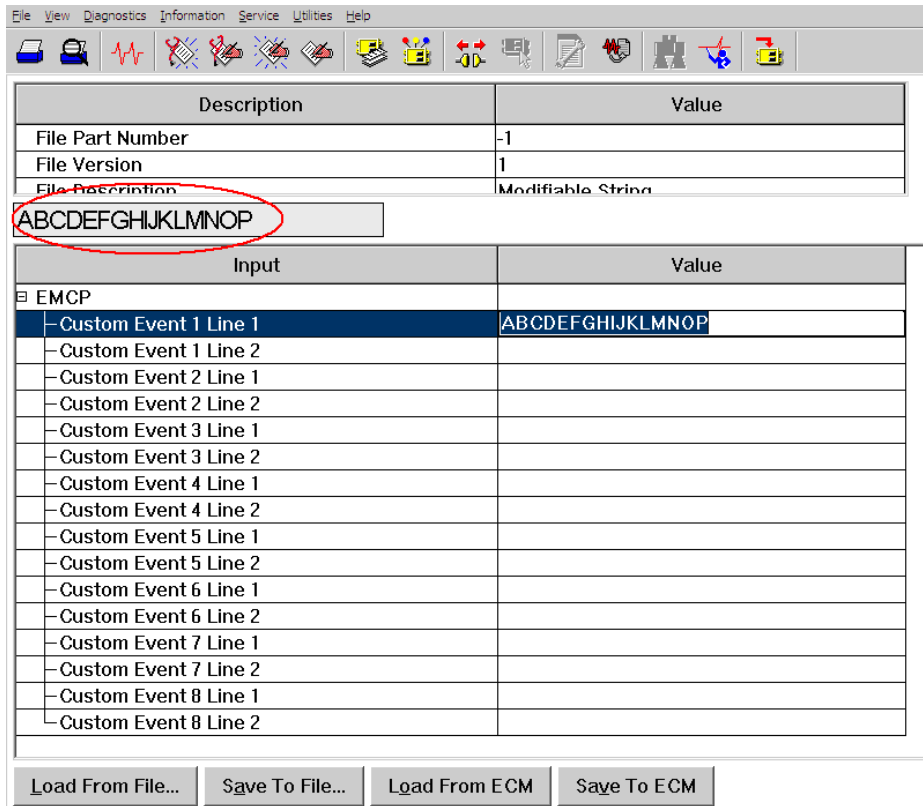

- Once all text strings are entered for all events desired, click on the “Save to ECM” button on the bottom of the screen.

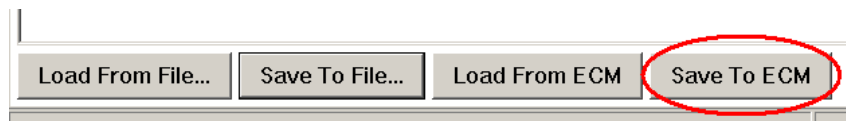

- To then save the same file to the hard disk, click on the “Save to File...” and browse to the appropriate folder.



9. Once the file destination is found, click "Save".

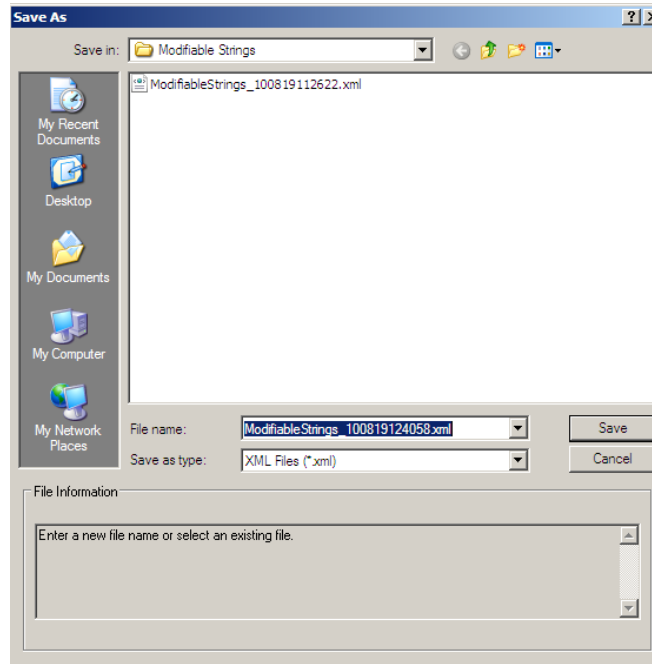

10. To edit a saved text string in ET while not connected to the ECM, navigate to File>Open>Modifiable String Data File. This is equivalent to clicking on the "Load From File..." button on the bottom left side of the "Modifiable Strings" screen.

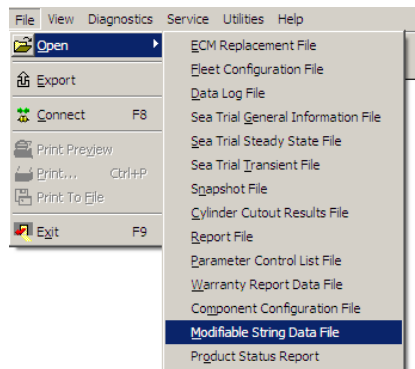

11. Select the desired string data and click "Open". This opens the "Modifiable Strings" screen again.
12. Edit as desired, then save to ECM, or save to a file.

**Note:** The Modifiable Text String parameter value's field is initially blank until it is replaced with a custom text string parameter value. The custom text string parameter value entered will replace the default strings.

The user's Custom Text Strings are displayed in the user's preferred language. If the service tool doesn't support the user's preferred language, US English will be used.

**Note:** The user must save any offline changes before attempting to connect the Service Tool to the EMCP 4, or the changes will not be saved.

## 12 SAVING AND RESTORING SETPOINTS

The EMCP 4 supports the saving and uploading of the EMCP 4 setpoints through a setpoint configuration file. This file, called the ECM Replacement File, or Fleet Replacement File, is accessible via the ECM Replacement tool of the Cat Service Tool software. The file contains information specific to the EMCP 4, and includes the setpoint values that are specific to a given EMCP 4 module. The user has the option of saving the data to an ECM Replacement File from an EMCP 4 module or uploading the data from the ECM Replacement File to another EMCP 4 module. The user also has the option of uploading general configuration data to several EMCP 4 modules by means of a similar tool called Fleet Configuration. Both of these options are accomplished through the Cat Service Tool software.

**Note:** This chapter only addresses setpoints residing in the EMCP 4. To save and restore setpoints for other (optional) modules on the EMCP 4 CAN data links, a similar procedure must be followed for each individual module.

### 12.1 SAVING EMCP 4 CONFIGURATION DATA

The Cat Service Tool is used to save an EMCP 4 configuration.

The EMCP 4 configuration should be saved upon initial access or after any configuration change. This will be required for future accessibility when exchanging or replacing the EMCP 4 module.

After connecting to the EMCP 4, navigate to Service > Copy Configuration (see Figure 27). There are two options:

- Fleet Configuration
- ECM Replacement

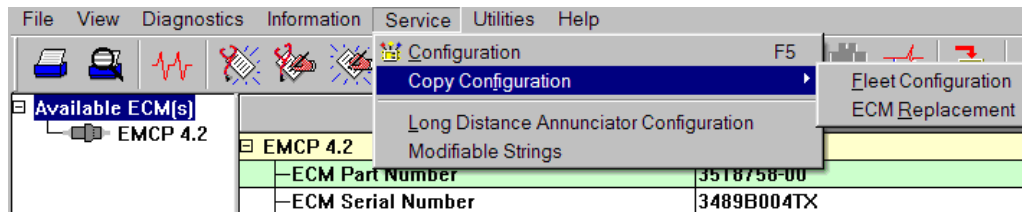

**Figure 27: Cat Service Tool EMCP 4 GSC Summary Screen**

The loading of EMCP 4 configuration data is very similar between **ECM REPLACEMENT** and **FLEET CONFIGURATION**. For illustration purposes, the **ECM REPLACEMENT** option will be described here.

## FLEET CONFIGURATION OPTION

Select the **FLEET CONFIGURATION** option when there is a need to save and copy **GENERAL DATA** to several ECMs (non-module-specific).

The **FLEET CONFIGURATION** tool works very similar to the ECM Replacement tool, with the exception of ignoring module-specific data such as **ENGINE SERIAL NUMBER** and **ENGINE OPERATING HOURS**.

## ECM REPLACEMENT OPTION

To save EMCP 4 configuration data to an ECM Replacement file:

1. From the Service Tool menu, select the following: Service > Copy Configuration > ECM Replacement. See Figure 27.
2. The software will prompt the user to open a previously saved ECM Replacement file. Click "Cancel".
3. The following message is displayed: "**No Data Is Available. Load From ECM Now?**" Press "No".
4. Click "**Load from ECM**" from the bottom left of the ECM Replacement screen to bring up the setpoints. See Figure 28.

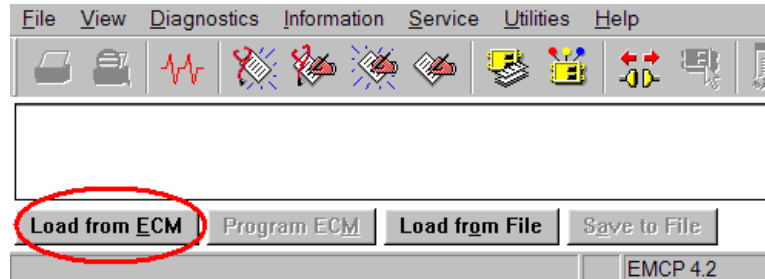

**Figure 28: Load from ECM**

- After the software loads the data, the replacement file parameters will be shown. See Figure 29.

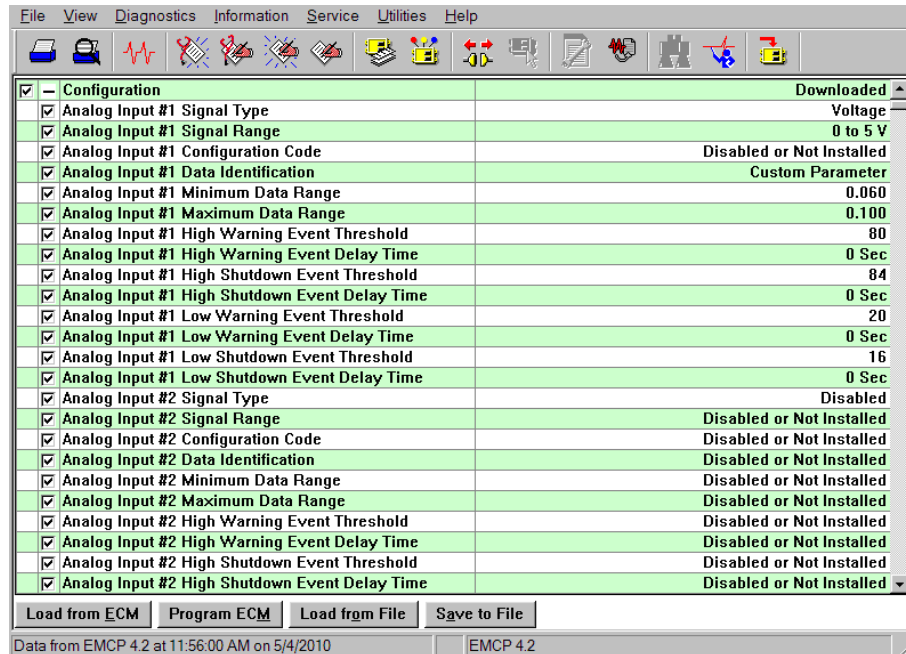

**Figure 29: ECM Replacement File Parameters**

- Select which ECM's configuration data is to be viewed and/or saved for future use by adding, or removing check boxes from the side of the parameters.
- After any selection changes are completed, click "**Save to File**" from the bottom of the ECM Replacement screen to save the file. See Figure 30. Make sure to note where the file is stored.

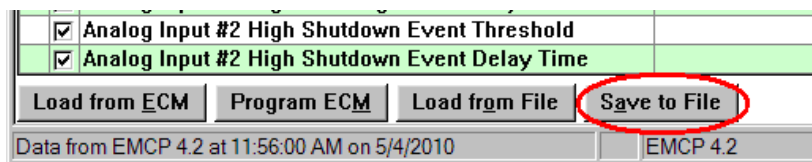

**Figure 30: Save to File**

**Note:** The configuration data must be saved to a file before disconnecting from the service tool or the data **WILL BE LOST** and must be re-loaded from the source module again.

## 12.2 LOADING EMCP 4 CONFIGURATION DATA

The loading of EMCP 4 configuration data is very similar between **ECM REPLACEMENT** and **FLEET CONFIGURATION**. For illustration purposes, the **ECM REPLACEMENT** option will be described here.

**Warning:** When loading an ECM Replacement File, the engine operating hours will increase to the newly loaded value (if larger than the old value). To avoid this, deselect the Engine Operating Hours setting.

To load an ECM Replacement file to an EMCP 4:

1. From the Service Tool menu, select the following: Service > Copy Configuration > ECM Replacement. See Figure 27.
2. The software will prompt the user to open a previously saved ECM Replacement file.
3. Navigate to the location where the file is stored and click "Open".
4. The software will confirm opening the file. See Figure 31. Click "OK".

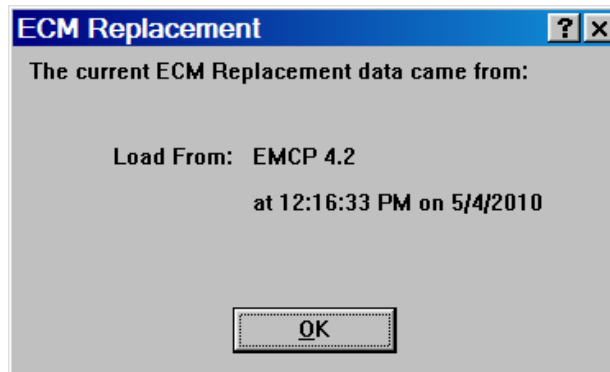

**Figure 31: Load from File**

5. The replacement file parameters will be shown. See Figure 32.

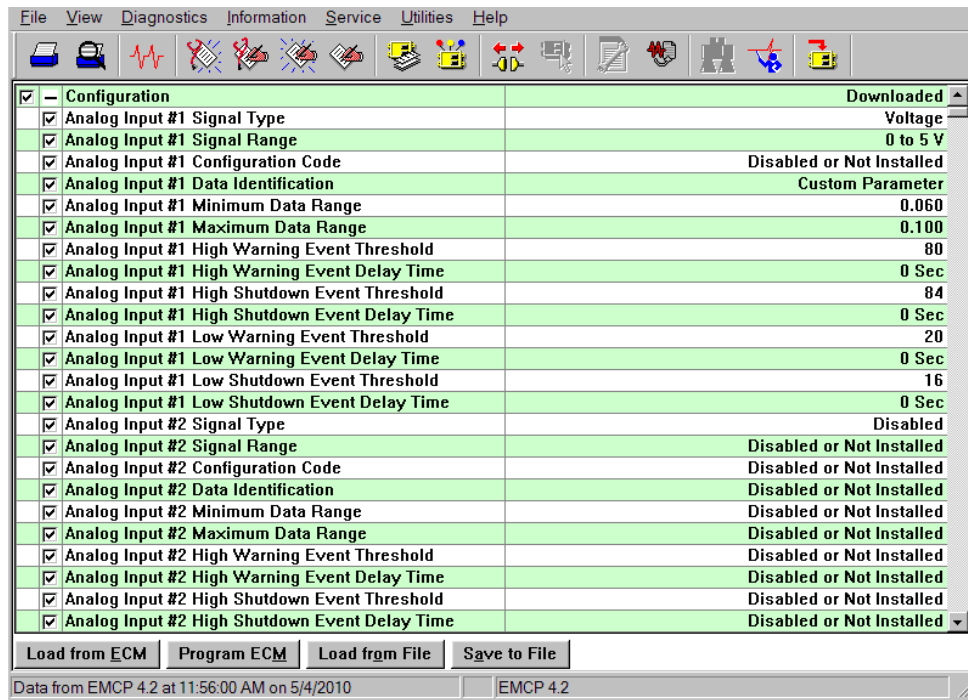

**Figure 32: ECM Replacement File Parameters**

6. Select which ECM's configuration data is to be programmed into the EMCP 4 by adding, or removing check boxes from the side of the parameters.
7. After any selection changes are completed, click "**Program ECM**" from the bottom of the ECM Replacement screen to load the file into the EMCP 4. See Figure 33.

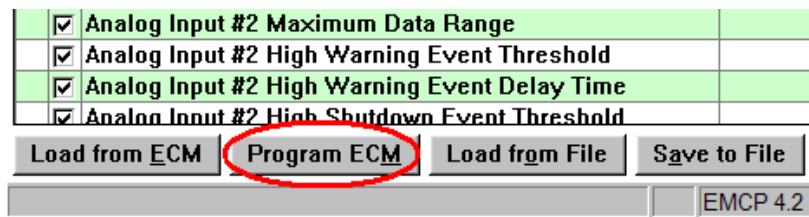

**Figure 33: Program ECM**

8. If another replacement file is to be programmed or if the user is already at the ECM Replacement screen prior to opening a replacement file, press the “Load from File” button at the bottom of the screen and follow steps 3 through 7 above. See Figure 34.

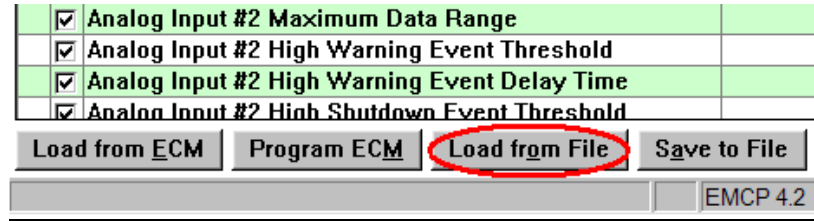

**Figure 34: Load ECM Replacement File**

**Note:** By default, ECM Replacement files are stored in the ECM Replacement folder, while Fleet Configuration files are stored in the Fleet Configuration folder.

The above steps, for uploading saved configuration data, will need to be repeated for each EMCP 4 module needing same or similar setpoint configurations. For programming multiple units with the same setpoints, it is recommended to use Fleet Configuration files.

**Note:** When programming **EVENT RESPONSE CONFIGURATION** setpoints, the control must be in **STOP** mode. If the control is not in **STOP**, there will be a message after the programming is complete. The message will show that none of the Event Response Configuration setpoints were changed.

## 13 PROGRAMMABLE CYCLE TIMER (EMCP 4.2 ONLY)

The Programmable Cycle Timer (PCT) feature allows the operator to program seven independent times, when tasks (called PCT Outputs), will be activated or deactivated automatically during the week. This is useful for exercising gensets, or cases where two or more generators are required to automatically share the duty of supplying a load throughout the week.

Using the PCT, each genset can be programmed to start and stop at pre-set times. The PCT is capable of handling a seven day sequence with seven independent starts happening one or more times each week. The timing of these start/stop cycles may be programmed in advance, either locally or via the service tool.

For example, if a standby set does not have access to a utility supply to power a trickle charger, the PCT can be set for an hour a week to keep the battery charged.

**Caution:** External equipment such as a transfer switch is required to ensure that the gensets are not stopped on load.

The **PCT FEATURE** consists of seven independent timers; each timer has the following setpoints (setpoints shown are for PCT #1):

**PROGRAMMABLE CYCLE TIMER #1: Activation Day of the Week:**

This permits independent selection of each day (Sun -> Sat) that the timer will activate. All seven days can be selected, if desired.

**PROGRAMMABLE CYCLE TIMER #1: Activation Start Time**

The time of day (in hours and minutes) that the timer will activate. The time must be programmed using a 24-hour clock.

**PROGRAMMABLE CYCLE TIMER #1: Active Time**

The duration (in hours and minutes) for which the timer will be active (up to 24 hours).

**PROGRAMMABLE CYCLE TIMER #1: Output #1 Activation Configuration**

The Programmable Cycle Timer's first output will be activated when this timer is active and will allow the genset to start if in Auto.

**PROGRAMMABLE CYCLE TIMER #1: Output #2 Activation Configuration**

The Programmable Cycle Timer's second output will be activated when this timer is active. Output # 2 can be assigned to a programmable output for connection to an external device. This external device can be used to control a load bank, transfer switch or other device.

The PCT has two internal outputs; these should not be confused with the physical outputs of the control. The outputs are connected internally to the control module. In the standard configuration, **PCT OUTPUT #1** is connected to a Remote Initiate command. **OUTPUT #2** is customer configurable via a discrete output. This allows the operator to configure a timed relay, for external connectivity.

**Note:** The outputs of all seven timers are tied together in an "OR" fashion. This means that if any one, or more, timer is activated, then any output will activate (depending on programming).

The status of each output is indicated by a **1**, **0**, or **-** in the **PROG CYCLE** column under #1 through #7. See Figure 35.

A number **ONE (1)** means that this PCT is driving that output to be **TRUE**

A number **ZERO (0)** means that this PCT is **NOT** driving this output true now, but, this output is programmed to be TRUE at another time.

A **DASH (-)** means that this PCT is **NOT** programmed to activate this output.

PCT	1	2	3	4	5	6	7
PCT OUTPUT1	0	-	1	-	-	-	-
PCT OUTPUT2	-	-	0	-	1	-	-



**Figure 35: PCT Main Screen**

In Figure 35, **PCT #1** is **INACTIVE** on Output #1. Output #2 is **NOT** enabled and will never activate, as programmed.

**PCT #3** is **ACTIVE** on Output #1, and **INACTIVE** on Output #2.

**PCT #5** is **NOT** enabled and will never activate, as programmed, on Output #1. Output #2 is **ACTIVE**.

**PCT #2, PCT #4, PCT #6, and PCT #7** are **DISABLED**. They **NEVER** activate Output #1 or Output #2, as programmed.

To select a specific Programmable Cycle Timer, use the **LEFT**  and **RIGHT**  buttons until the desired PCT is within the selection box and then press the **OK KEY**



### 13.1 CONFIGURING THE PROGRAMMABLE CYCLE TIMER USING THE DISPLAY

To configure a Programmable Cycle Timer with the display, go through the following menu options:

At **MAIN MENU**, scroll down  to **CONTROL**

Press the **OK KEY** 

Scroll **DOWN**  to **PROG CYCLE TIMER**

Press the **OK KEY** 

The box surrounding the first column outlines the first of seven timers.

Press the **OK KEY**  to program this timer.

The box surrounding the first row outlines the day selection.

Press the **OK KEY**  to select the day(s) for this timer.

Use the **UP**  and **DOWN**  arrow keys

along with the **LEFT**  and **RIGHT**  arrow keys to select the days that this timer will activate.

Press the **OK KEY**  when done.

Scroll **DOWN**  to select the **START TIME**

Press the **OK KEY** 

Use the arrow keys to enter the **START TIME**

Press the **OK KEY**  when done.

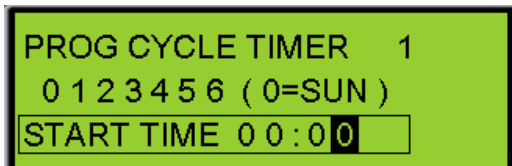
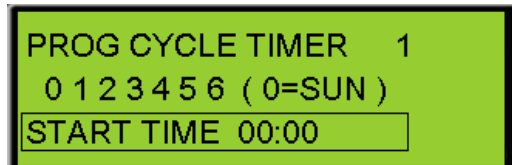
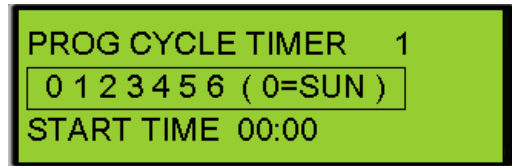
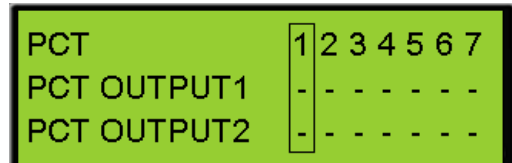
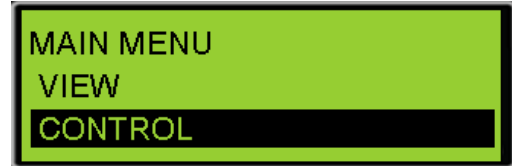

Scroll **DOWN**  to select the **RUN FOR** time

Press the **OK KEY** .

Use the arrow keys to enter the **RUN FOR** time

Press the **OK KEY**  when done.

Scroll **DOWN**  to select the **OUTPUT STATE** for Output #1

Press the **OK KEY** .

Select the **OUTPUT STATE** that you want to program

Press the **OK KEY**  when done.

Scroll **DOWN**  to select the **OUTPUT STATE** for Output #2



Press the **OK KEY** .

Select the **OUTPUT STATE** that you want to program

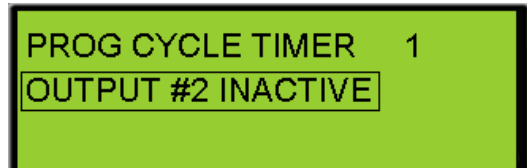
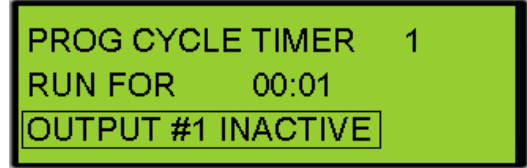
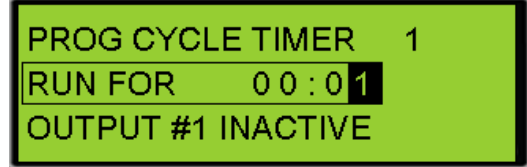
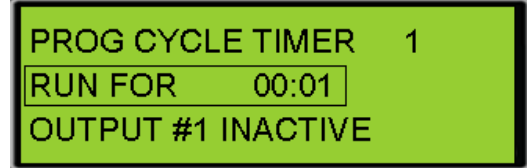
Press the **OK KEY**  when done.



Press the **ESCAPE KEY**  to return to the Programmable Cycle Timer main screen. Use the

**LEFT**  and **RIGHT**  buttons to select the other timers and repeat the above steps.

### 13.2 CONFIGURING THE PROGRAMMABLE CYCLE TIMER USING THE CAT SERVICE TOOL

To configure a Programmable Cycle Timer with the Cat Service Tool, go through the following menu options:

1. Connect to the EMCP 4 using the Cat Service Tool as stated in Chapter 4.2.

2. Select Programmable Cycle Timer on the left.

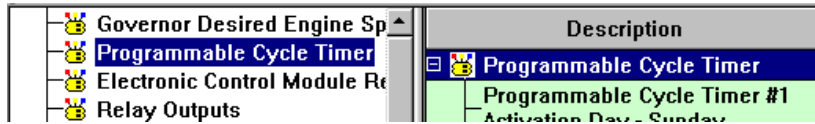

3. Double click the Programmable Cycle Timer #N Activation Day setpoint for a given day to change this value from the drop down menu. Click the OK button to program.

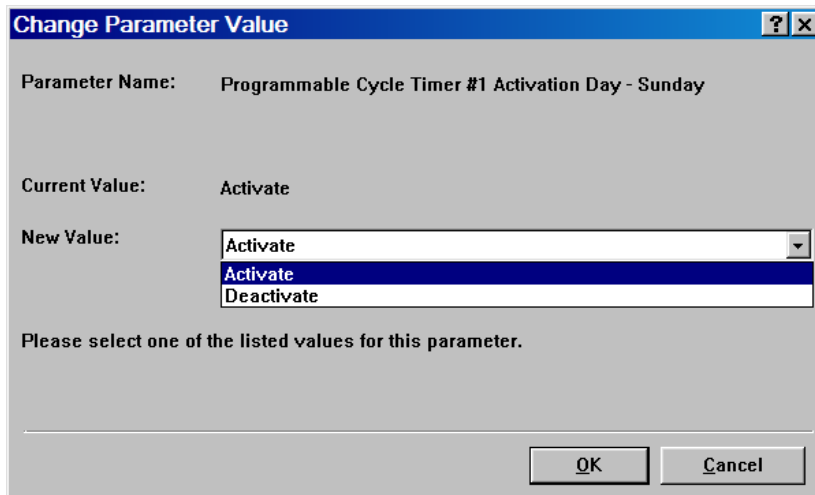

4. Double click the Programmable Cycle Timer #N Activation Start Time setpoint to change this value. Click the OK button to program.

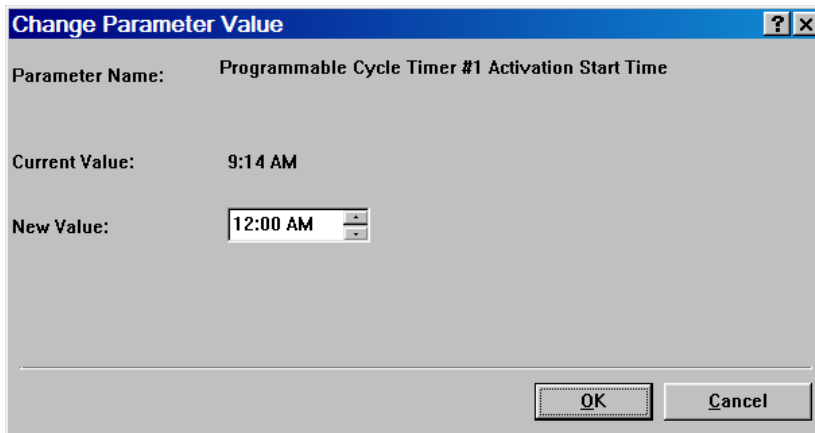

5. Double click the Programmable Cycle Timer #N Active Time setpoint to change this value. Click the OK button to program.

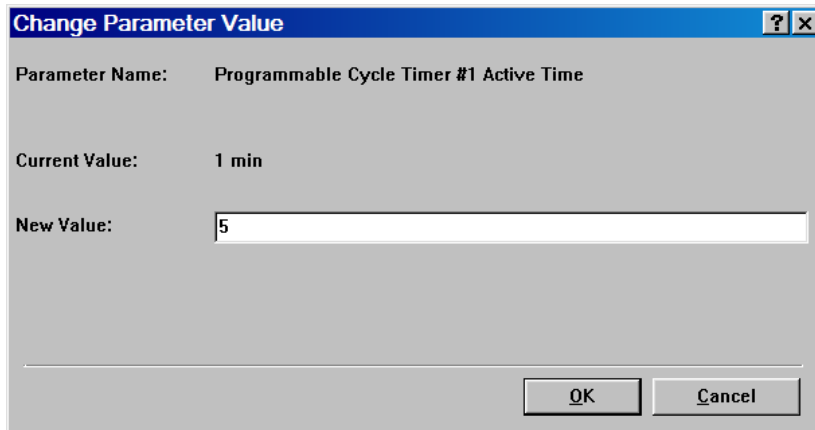

The screenshot shows a dialog box titled "Change Parameter Value" with a blue header bar containing a help icon and a close button. The dialog has a light gray background. It contains the following text and controls:

- Parameter Name:** Programmable Cycle Timer #1 Active Time
- Current Value:** 1 min
- New Value:** A text input field containing the number "5".
- At the bottom right, there are two buttons: "OK" and "Cancel".

6. Double click the Programmable Cycle Timer #N Output #1 Active Configuration setpoint to change this value from the drop down menu. Click the OK button to program.

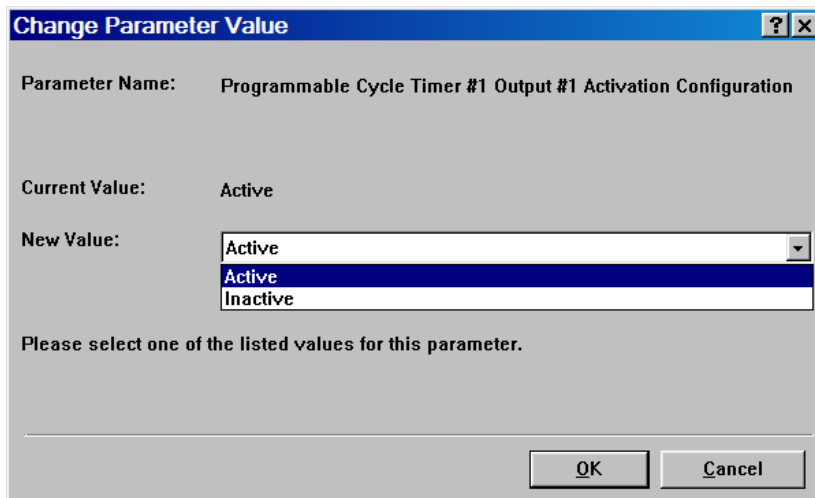

The screenshot shows a dialog box titled "Change Parameter Value" with a blue header bar containing a help icon and a close button. The dialog has a light gray background. It contains the following text and controls:

- Parameter Name:** Programmable Cycle Timer #1 Output #1 Activation Configuration
- Current Value:** Active
- New Value:** A drop-down menu with "Active" selected. The menu is open, showing "Active" and "Inactive" as options.
- Below the menu, the text "Please select one of the listed values for this parameter." is displayed.
- At the bottom right, there are two buttons: "OK" and "Cancel".

7. Double click the Programmable Cycle Timer #N Output #2 Active Configuration setpoint to change this value from the drop down menu. Click the OK button to program.

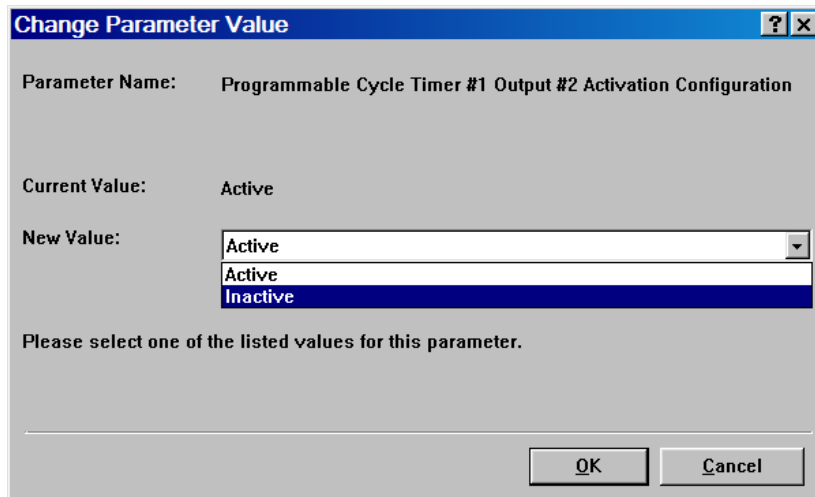

**Change Parameter Value** [?] [X]

Parameter Name: Programmable Cycle Timer #1 Output #2 Activation Configuration

Current Value: Active

New Value:   
Active  
Inactive

Please select one of the listed values for this parameter.

OK Cancel

8. Repeat the above steps to program additional timers.

---

## 14 REDUCED POWER MODE

**REDUCED POWER MODE (RPM)** is a feature that puts the control into a state where the power consumption is reduced. RPM is intended to extend the amount of time the generator can sit between runs before the control drains the batteries too low to crank the generator in cases where a battery trickle charger is not fitted.

In order to reduce the power consumed when in RPM, many functions within the control are turned **OFF**.

### TURNED OFF DURING RPM

- The display
- The communication lines, including Annunciator communication
- All inputs except Remote Initiate
- All outputs
- LED's (lamps) on the front of the control blink briefly every second (rather than being on continuously).

When RPM is enabled, the control will only enter RPM after a programmable time delay provided the generator is stopped and no keys have been pressed during the delay time.

The control will wake from RPM on any one of the following conditions:

### WAKE FROM RPM

- Sending a hardwired remote start signal to the controller
- Cycling power to the controller
- A key on the keypad is pressed
- The Programmable Cycle Timer is about to enter a period when it will activate an output.

### ACTIONS TO ENABLE RPM

1. Change the setpoint Reduced Power Mode Enable Status to **ENABLED**. This can be done with either ET or using a level 3 password to navigate to Configure -> All Setpoints -> Reduced Power Mode.
2. The setpoint Reduced Power Mode Delay Time should be checked. It should be at a desirable value. This value is the amount of time (once the generator is at rest and after the last key-press) before the control will go into Reduced Power Mode.

The following conditions must be met in order for the EMCP 4 to enter Reduced Power Mode:

1. Engine speed must be 0
2. Remote Initiate signal cannot be active
3. Must not be close to a Programmed Cycle Timer

**SEMI-AWAKE**

The EMCP 4 becomes **SEMI-AWAKE** when in Reduced Power Mode. Approximately every 30 minutes it will do status checks of the control for about 40 seconds. During **SEMI-AWAKE** the display remains off and the LED's (lamps) continue to blink. The EMCP will start up to check for Analog Input faults, engine speed sensor diagnostics, and AC faults. If any of these faults become active at this time, the system will respond accordingly (warning or shutdown LED indicators may turn on). During the semi-awake time any active relays (such as common alarm) will energize.

Once the **SEMI-AWAKE** time is completed the control will return to full RPM (deactivating any relays that are active). An active event will not prevent the control from entering reduced power mode. If a programmable cycle timer is set to become active in the near future, the timer before waking will be adjusted to ensure the controller wakes in time to process the programmable cycler timer.

---

## 15 PROGRAMMABLE KW RELAY FUNCTION (EMCP 4.2 ONLY)

The EMCP 4.2 has two Programmable kW Relay functions configured to respond to the %KW of the genset. These functions can be mapped to the EMCP Outputs.

The setpoints within the Programmable kW Relay functions can be changed from the display, and are as follows:

### **PROGRAMMABLE TRIP POINT #N TRIGGER CONDITION**

Choices: Disabled, Trip Above Threshold, Trip Below Threshold

This selects whether the output will be active if the value is above or below the threshold.

### **PROGRAMMABLE TRIP POINT #N PERCENTAGE THRESHOLD**

Range: -100-100%

This is the threshold of rated kW that the function must pass in order to change the state of the output.

### **PROGRAMMABLE TRIP POINT #N HYSTERESIS PERCENTAGE**

Range: -100-100%

Once the output is on, the value must return by this much *past* the Threshold before the output turns off again. For example, if this value is 5% and the Percentage Threshold is 90%, then the relay will activate at 90% but not turn off again until 85% of rated kW (90-5). This hysteresis is used to ensure that a value close to the threshold does not cause the output to oscillate.

### **PROGRAMMABLE TRIP POINT #N TRIP ACTIVATION DELAY TIME**

Range: 0-120 seconds

This is the time that the value must exceed the threshold before the relay becomes active. It is used to ensure that the momentary transients are ignored.

### **PROGRAMMABLE TRIP POINT #N TRIP DEACTIVATION DELAY TIME**

Range: 0-120 seconds

This is the time that the value must return past the threshold before the relay becomes inactive again. It is used to ensure that the momentary transients are ignored.

## 15.1 CONFIGURING THE PROGRAMMABLE KW RELAY FROM THE DISPLAY

To configure a Programmable kW Relay with the display, go through the following menu options:

AT THE MAIN MENU, scroll down  to CONFIGURE



Press the OK KEY 

SCROLL DOWN  to ALL SETPOINTS



Press the OK KEY 

SCROLL DOWN  to PROG kW RELAY TRIP



Press the OK KEY 

Select the PROG kW RELAY TRIP that you want to program



Press the OK KEY 

Press the OK KEY  to highlight the current configuration.

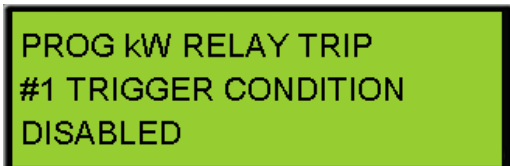

Select the type of PROG kW RELAY TRIP #N TRIGGER CONDITION that you want to program (DISABLED, TRIP BELOW THRESH, TRIP ABOVE THRESH).



Press the OK KEY 

Scroll DOWN  to PROG kW RELAY TRIP #N PERCENTAGE THRESHOLD

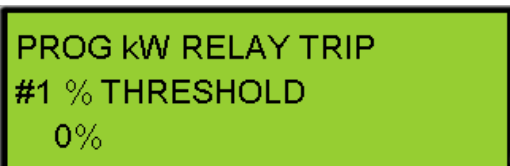

Press the OK KEY  to edit the current PROG kW RELAY TRIP #N PERCENTAGE THRESHOLD.

Select the **PROG KW RELAY TRIP #N PERCENTAGE THRESHOLD** that you want to program

Press the **OK KEY** 

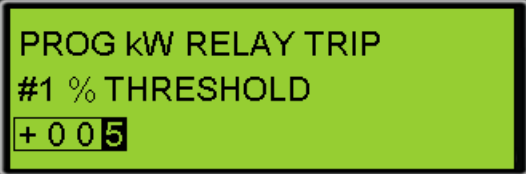

Scroll **DOWN**  to **PROG KW RELAY TRIP #N HYSTERESIS PERCENTAGE**

Press the **OK KEY**  to edit the current **PROGRAMMABLE TRIP POINT FUNCTION #N HYSTERESIS PERCENTAGE**.



Select the **PROG KW RELAY TRIP #N HYSTERESIS PERCENTAGE** that you want to program

Press the **OK KEY** 

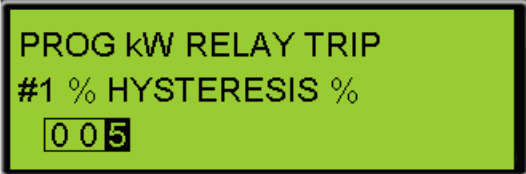

Scroll **DOWN**  to **PROG KW RELAY TRIP #N TRIP ACTIVATION DELAY TIME**

Press the **OK KEY**  to edit the current **PROGRAMMABLE TRIP POINT FUNCTION #N TRIP ACTIVATION DELAY TIME**.

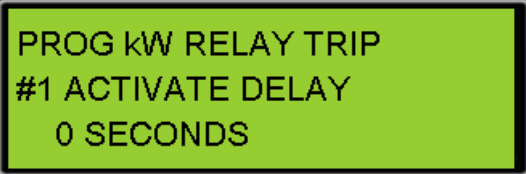

Select the **PROG KW RELAY TRIP #N TRIP ACTIVATION DELAY TIME** that you want to program

Press the **OK KEY** 

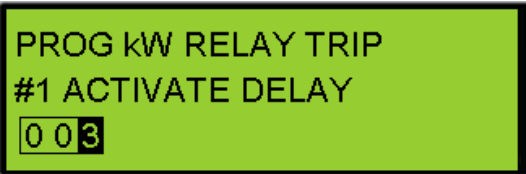

Scroll **DOWN**  to **PROG KW RELAY TRIP #N TRIP DEACTIVATION DELAY TIME**

Press the **OK KEY**  to edit the current **PROG KW RELAY TRIP #N TRIP DEACTIVATION DELAY TIME**.

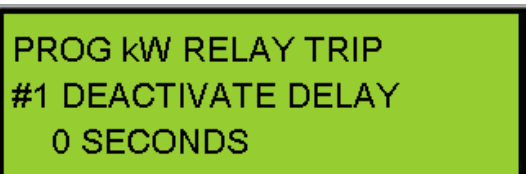

Select the **PROG KW RELAY TRIP #N TRIP DEACTIVATION DELAY TIME** that you want to program

Press the **OK KEY** 

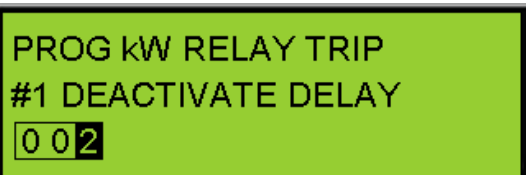

## 15.2 CONFIGURING THE PROGRAMMABLE KW RELAYS USING THE CAT SERVICE TOOL

To configure a Programmable kW Relay with the Cat Service Tool, go through the following menu options:

1. Connect to the EMCP 4 using the Cat Service Tool as stated in Chapter 4.2.
2. Select kW Relay Setpoints on the left.

Programmable Cycle Time	Trigger Condition	
Electronic Control Module	Programmable Trip Point Function #2	0 %
Relay Outputs	Percentage Threshold	
Service Maintenance Inputs	Programmable Trip Point Function #2	0 %
<b>kW Relay Setpoints</b>	Hysteresis Percentage	
DIO Inputs	Programmable Trip Point Function #2	0 %

3. Double click the Programmable Trip Point #N Trigger Condition setpoint to change this value from the drop down menu. Click the OK button to program.

**Change Parameter Value** ? x

Parameter Name: Programmable Trip Point Function #1 Trigger Condition

Current Value: Disabled

New Value:

Disabled

**Disabled**

Trip Above Threshold

Trip Below Threshold

Please select one of the listed values for this parameter.

4. Double click the Programmable Trip Point #N Percentage Threshold setpoint to change this value. Click the OK button to program.

The screenshot shows a dialog box titled "Change Parameter Value" with a blue header bar containing a question mark icon and a close button. The dialog has a light gray background. It contains the following text and fields:

- Parameter Name: Programmable Trip Point Function #1 Percentage Threshold
- Current Value: 0 %
- New Value: 90 (text input field)

At the bottom right, there are two buttons: "OK" and "Cancel".

5. Double click the Programmable Trip Point #N Hysteresis Percentage setpoint to change this value. Click the OK button to program.

The screenshot shows a dialog box titled "Change Parameter Value" with a blue header bar containing a question mark icon and a close button. The dialog has a light gray background. It contains the following text and fields:

- Parameter Name: Programmable Trip Point Function #1 Hysteresis Percentage
- Current Value: 0 %
- New Value: 5 (text input field)

At the bottom right, there are two buttons: "OK" and "Cancel".

6. Double click the Programmable Trip Point #N Output #1 Trip Activation Delay Time setpoint to change this value from the drop down menu. Click the OK button to program.

The screenshot shows a dialog box titled "Change Parameter Value" with a blue header bar containing a question mark icon and a close button. The dialog has a light gray background. It contains the following text and fields:

- Parameter Name: Programmable Trip Point Function #1 Trip Activation Delay Time
- Current Value: 0 Sec
- New Value: 10 (text input field)

At the bottom right, there are two buttons: "OK" and "Cancel".

7. Double click the Programmable Trip Point #N Output #12 Trip Deactivation Delay Time setpoint to change this value from the drop down menu. Click the OK button to program.

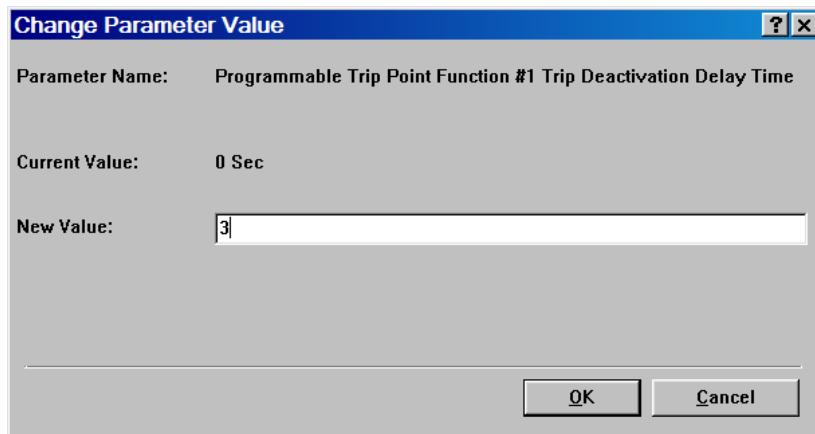

**Change Parameter Value** ? x

Parameter Name: Programmable Trip Point Function #1 Trip Deactivation Delay Time

Current Value: 0 Sec

New Value: 3

OK Cancel

8. Repeat the above steps to program an additional timer.

## 16 CAN DATA LINKS

### 16.1 PRIMARY CAN DATA LINK (CAN 1)

The Primary CAN Data Link is supported by all levels of the EMCP 4.

The Primary CAN Data Link is used for local communication among modules associated with a single genset. These include one or two engine Electronic Control Modules (ECM), the Cat Digital Voltage Regulator (Cat DVR), a Thermocouple Module, and the Cat Clean Emissions Module System. The EMCP 4 can interface with both EUI and MUI engines; in MUI engines, the engine sensors are wired directly to the EMCP 4.

For the expansion modules, logs are not kept if power is cycled.

#### PRIMARY CAN WIRING

The Primary CAN communication wires are brought out of the EMCP 4 as part of the 70-pin connector. The pins, as designated on the EMCP 4 connector, are shown in Table 12.

PRIMARY CAN COMMUNICATION WIRES		
Pin #	Name	Description
34	CAN 1 -	Differential (-) for CAN
42	CAN 1 SH	Shield for CAN
50	CAN 1 +	Differential (+) for CAN

**Table 12: Primary CAN Data Link on the 70-pin EMCP 4 connector**

#### NETWORK TOPOLOGY

The physical topology of the CAN network used in the Primary CAN Data Link is a bus topology, consisting of a main trunk and small drops.

- The maximum allowable trunk length is 130 ft (40 m), and the maximum drop length is 3 ft (1 m).
- The CAN network requires a 120 ohm termination resistor on the extreme ends of the main trunk.

An example of the topology for the EMCP 4.1 and 4.2 is illustrated in Figure 36.

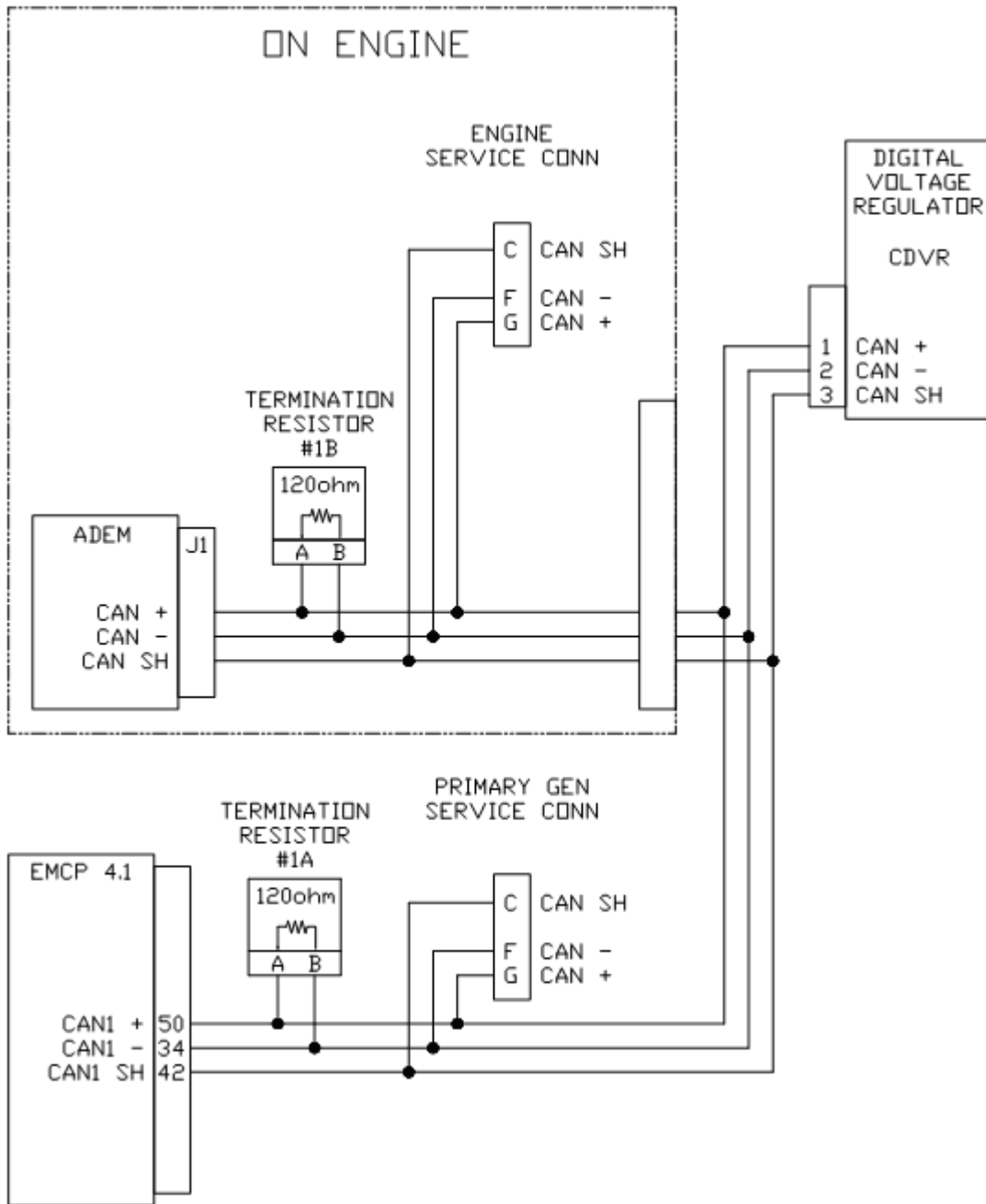

**Figure 36: EMCP 4.1 CAN 1 Wiring Diagram**

## 16.2 ACCESSORY CAN DATA LINK (CAN 2) (EMCP 4.2 ONLY)

The Accessory CAN Data Link is not supported by the EMCP 4.1.

The Accessory Data Link (CAN 2) is used for local or remote communication among modules associated with a single genset. These include a Resistance Temperature Device (RTD) Module, a Thermocouple Module, up to four Digital Input/Output Modules, and up to four Annunciators.

### ACCESSORY CAN WIRING

The Accessory CAN communication wires are brought out of the EMCP 4.2 as part of the 70-pin connector. The pins, as designated on the EMCP 4 connector, are shown in Table 13.

ACCESSORY CAN COMMUNICATION WIRES		
Pin #	Name	Description
64	CAN 2 -	Differential (-) for CAN
63	CAN 2 SH	Shield for CAN
62	CAN 2 +	Differential (+) for CAN

**Table 13: EMCP 4.2 Accessory CAN Data Link on 70-pin EMCP 4 connector**

### NETWORK TOPOLOGY

The physical topology of the CAN network used in the Accessory CAN Data Link is a bus topology, consisting of a main trunk and small drops.

- The maximum allowable trunk length is 800 ft (250 m), and the maximum drop length is 9 ft (3 m).
- The CAN network requires a 120 ohm termination resistor on the extreme ends of the main trunk.

The topology for the EMCP 4.2 in the default configuration, with no remote devices connected, is illustrated in Figure 36.

The topology for the EMCP 4.2 with some remote devices connected is illustrated in Figure 37.

**Note:** The devices shown in Figure 37 are only representative; more remote devices can be connected, as long as the proper lengths are maintained, and the termination resistor is placed at the end of the trunk. Refer to Chapter 17 for the maximum number of devices supported on each level.

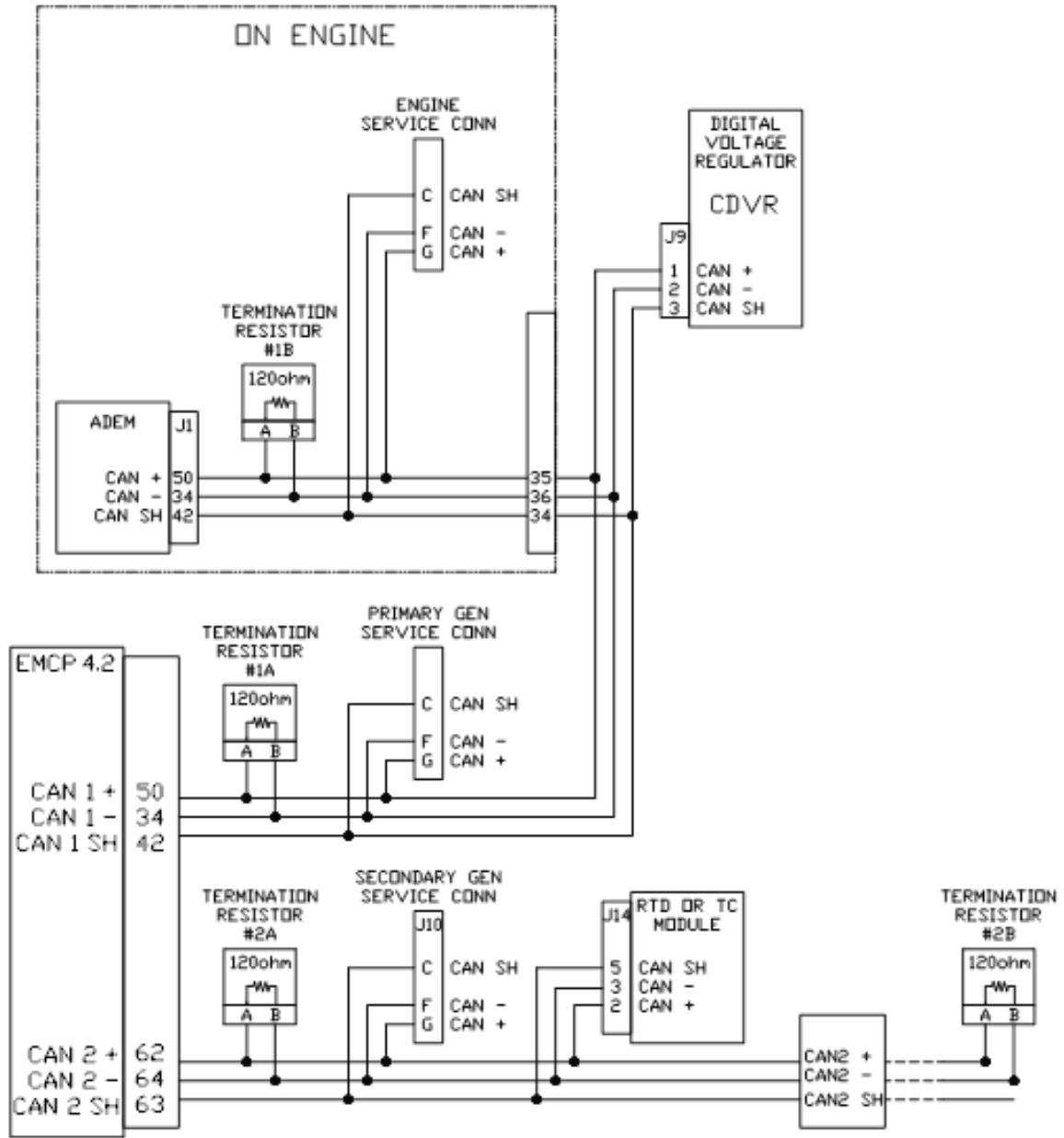

**Figure 37: EMCP 4.2 CAN 1 and CAN 2 Wiring Diagram (With Optional Modules)**

## 17 OPTIONAL MODULES

The EMCP 4 consists of the EMCP 4 Genset Controller, as well as some optional auxiliary modules. These modules connect to the EMCP 4 via either the Primary or Accessory CAN Data Link, or an RS-485 SCADA Data Link (Modbus RTU, Half Duplex). The EMCP 4 can also communicate with a Cat electronic engine controller on the CAN network (though this is not considered an optional module).

Different numbers of modules are supported for different levels of EMCP 4. The numbers of modules supported on the CAN networks are given in Table 14.

MODULE	EMCP 4.1	EMCP 4.2	
	Primary CAN 1	Primary CAN 1	Accessory CAN 2
Electronic Engine Controller	1 or 2	1 or 2	0
CDVR	1	1	0
CAN Annunciator	0	0	4
Thermocouple	0	1	1
RTD	0	0	1
DIO	0	0	4

**Table 14: Number of Optional Modules Supported on CAN Networks**

**Note:** The number of RS-485 Annunciators is only limited by the RS-485 standard (none are supported on the EMCP 4.1).

For more information about connecting modules to the CAN data links, refer to Chapter 16.2 Accessory CAN Data Link.

### THE ANNUNCIATORS

The CAN Annunciator module is an auxiliary alarm indication device, consisting of 16 pairs of indicator LED's, and an audible horn. Each pair can be individually configured based for an application, and a custom film kit is available to customize the graphic/text indication. For further information see Chapter 17.1.

The RS-485 Annunciator module is an auxiliary alarm indication device, consisting of 16 pairs of indicator LED's, and an audible horn. Each annunciator can be mapped to one of four predefined group of alarms (including custom groups) based on application needs. A custom film kit is available to customize the graphic/text indication. For further information see Chapter 17.2.

### THE THERMOCOUPLE, RTD, & DIO

EMCP 4 uses a common form factor for the three modules known as the Thermocouple, RTD (Resistance Temperature Detector) and DIO (Discrete I/O) modules. The same case design is used for all three.

The Thermocouple module, RTD module and DIO module feature identical rugged packaging and Deutsch IPD connectors. The only physical difference in packages between these three optional modules is that the DIO module has an LED to indicate communication network status.

Applications can include networked power generator set control systems.

For further information on the Thermocouple module see Chapter 17.2, for the RTD module see Chapter 17.4, and for the DIO module see Chapter 17.5.

## THE CAT DIGITAL VOLTAGE REGULATOR

The Cat Digital Voltage Regulator (Cat DVR) module is an auxiliary voltage regulator device, regulating the generator voltage and engine speed to provide optimal response to various load types and changes in load. It is connected to the generator exciter and field, and communicates with the EMCP 4 for monitoring purposes. For further information see RENR7941 Cat Digital Voltage Regulator.

### 17.1 CAN ANNUNCIATOR

The EMCP CAN Annunciator serves to display system alarm conditions and status indications. The CAN Annunciator has been designed for use on the EMCP 4 Accessory CAN Data Link and may be used in either Local or Remote applications, providing customers with enhanced site flexibility.

In Local application, the CAN Annunciator may be mounted on the Package generator set with the EMCP 4 to provide a complete package-mounted monitoring solution.

The Annunciator may also be mounted separately from the generator set to provide Remote indication of system operating and alarm conditions.

A maximum of four CAN Annunciators can be mounted locally or remotely and connected to the Accessory CAN 2 data link.



### CAN ANNUNCIATOR FEATURES

The Annunciator includes:

- Sixteen (16) LED pairs for annunciation of up to 32 system events

- An additional pair of LED's provides status indication of the CAN data link connection

- Can annunciate alarm conditions received from any module on the CAN data link

- Alarm Horn with Lamp Test and Alarm Acknowledge pushbuttons

- Configurable to NFPA 99/110 requirements for local and remote annunciation on Emergency Standby Generator Systems

- Provides a simple means to change the labels for the annunciation LED's for site specific requirements (Custom Label Kit purchased separately)

- Superior visibility of the LED's in direct sunlight

Graphic symbols along with text labels are provided next to each LED pair to indicate various alarms and events

Can be Mounted either locally on the package generator set or remotely (up to 800 feet) on the Accessory CAN Data Link

Designed and tested to meet stringent Impulse Shock and Operating Vibration requirements

288 mm (11.34 in) High x 158 mm (6.22 in) Wide x 66 mm (2.37 in) Deep

## **ANNUNCIATOR SPECIFICATIONS**

### **ELECTRICAL SPECIFICATIONS**

Control Power 12 VDC & 24 VDC nominal (9 – 32 VDC acceptable)

Over voltage capability is 80 VDC for 2 minutes @ 70°C

Reverse voltage capability is –32 VDC for 1 hour @ 70°C

Single, 6-pin connector provides both power and communication

Designed to meet relevant European standards for EMI/RFI/Immunity without the use of external filtering (UL Listed).

### **ENVIRONMENTAL SPECIFICATIONS**

Operating Temperature -40 to 70°C

Storage Temperature -50°C to +85°C

Relative Humidity 90%, non-condensing, 30°C to 60°C.

Failure Point 85°C (If the ambient temperature were to exceed 85°C, the device would **NOT** be expected to return to proper operation)

Can be mounted directly on the generator set panel or remotely

### **NETWORK COMMUNICATIONS INTERFACE**

Incorporates a communications port, able to operate on the EMCP 4 Accessory CAN Data Link

Node address is auto configurable

Optical isolation is provided for the CAN line

Module operates normally with loss of communication link, retaining configured setpoints in non-volatile memory

Configuration and firmware updates are accomplished with the Cat Service Tool over the CAN 2 network

## ANNUNCIATOR WIRING

The back of the CAN Annunciator module contains an 8-terminal screw terminal block. Attached to the block is a 6-pin Deutsch adapter. The pin outs for both are shown in Figure 38 and Table 15.

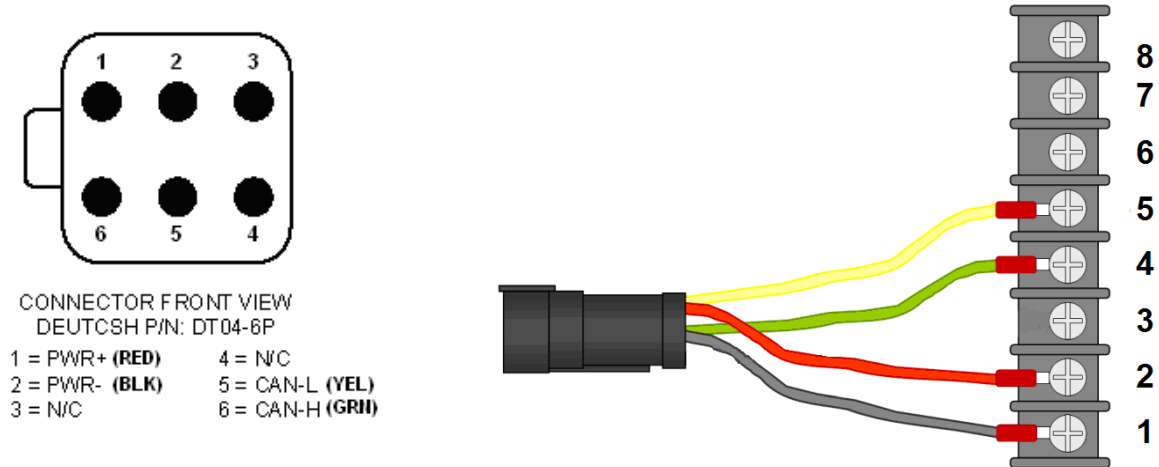

**Figure 38: Annunciator Deutsch Connector Pin Configuration and Terminal Block**

ANNUNCIATOR TERMINAL BLOCK PIN CONFIGURATION		
Terminal #	Function	Description
1	PWR-	- Battery Input
2	PWR+	+ Battery Input, also connects to Horn(+)
3	N/C	Not Connected
4	CAN2-H	CAN Data link HI
5	CAN2-L	CAN Data link LOW
6	Lamp Test	Lamp Test
7	Alarm Ack	Alarm Acknowledge
8	Horn Driver	Connects to negative terminal of Horn

**Table 15: Annunciator Terminal Block Pin Configuration**

**LED COLORS**

Each pair of LED's on the Annunciator consists of two of the following three colors: Green, Amber, and Red, which allows for custom configuration of **STATUS**, **WARNING** and **SHUTDOWN** conditions. The available colors and combinations are listed in Table 16 LED Colors:

LED COLORS					
ROW	LED 1	LED 2	ROW	LED 1	LED 2
1	Red	Amber	9	Red	Amber
2	Red	Amber	10	Red	Amber
3	Red	Amber	11	Red	Amber
4	Red	Amber	12	Red	Amber
5	Red	Amber	13	Green	Amber
6	Red	Green	14	Green	Amber
7	Red	Amber	15	Red	Green
8	Red	Amber	16	Red	Amber

**Table 16: LED Colors**

**MODULE STATUS LED**

A red/green pair located at the bottom of the CAN Annunciator, is used to report Module/Network Status. The various states indicated are explained in Table 17.

BEHAVIOR	EXPLANATION
Red solid	CAN 2 data link diagnostic. For example: the module is wired wrong (Data Link), wrong cable, or no terminating resistor.
Green solid	CAN 2 data link OK
Green flashing	No CAN 2 data link diagnostic, but no communication detected. Hooking the Annunciator up with the power on.
Red/Green alternating	No application software loaded

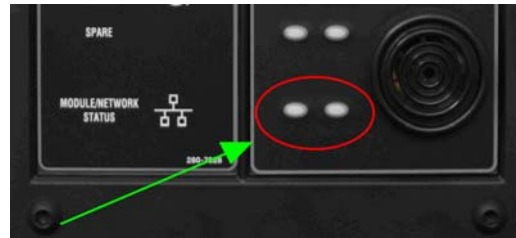

**Table 17: CAN Annunciator Module / Network Status LED Behavior**

## CAN ANNUNCIATOR SOFTWARE CONFIGURATION

The CAN Annunciator is field-programmable using the Cat Service Tool. It is also flash programmable to update software using the Cat Service Tool.

The service tool software must be installed on a Windows PC. The Cat communication adapter must be connected between the PC and the CAN 2 Accessory data link on which the target CAN 2 Annunciator is connected.

## GLOBAL ACKNOWLEDGE

The CAN Annunciator can be configured to both initiate and respond to an Event Acknowledge message over the CAN Accessory data link. If this setpoint is enabled, the CAN Annunciator events may be acknowledged locally on the CAN Annunciator by pressing the Alarm Acknowledge button or remotely by pressing the Alarm Acknowledge button on the EMCP 4 or by pressing the Acknowledge button on another CAN Annunciator configured for Global Acknowledge that is on the same data link. Acknowledging events also silences the horn.

The default setting for this setpoint is DISABLED, but it can be enabled from the Configuration tool within Cat Electronic Technician.

## ECU INSTANCE NUMBER

The Module Description will also indicate a number that identifies the CAN Annunciator uniquely from any other CAN Annunciator modules on the Accessory CAN Data Link.

This number is called the **ECU INSTANCE** and it is programmable.

The service tool configuration screen identifies the serial number of the CAN Annunciator that is connected. This is important in matching the desired ECU Instance to the actual hardware.

**Note:** If two CAN Annunciators on the same communications network are programmed for the same ECU Instance number, neither will communicate.

## CONFIGURING ANNUNCIATOR LED BEHAVIOR

1. Connect to the Annunciator using the Cat Service Tool as stated in Chapter 4.2.
2. Select Configuration Group #N from the left pane.

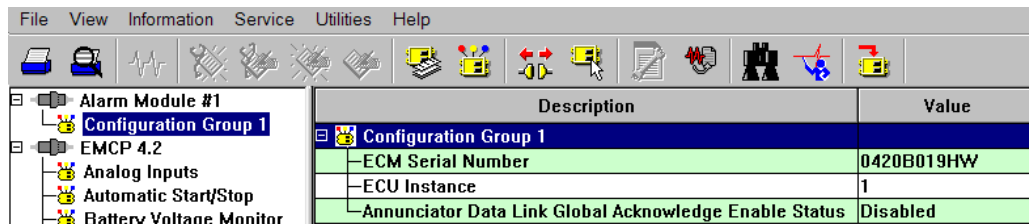

3. Double click ECU Instance Number to enter a new ECU Instance Number.

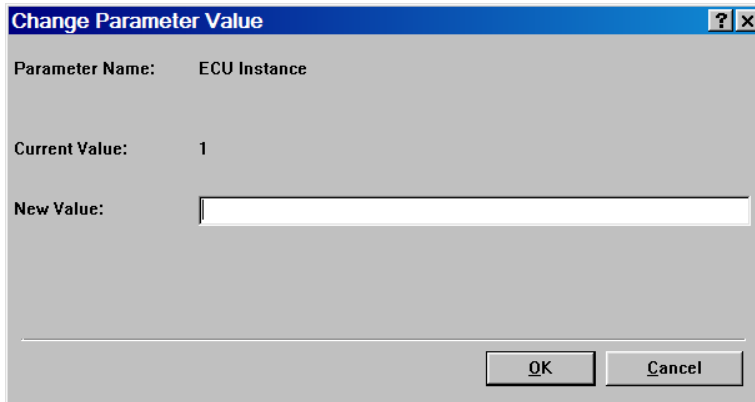

4. Double click Annunciator Data Link Global Acknowledge Enable Status to change this value from the drop down menu.

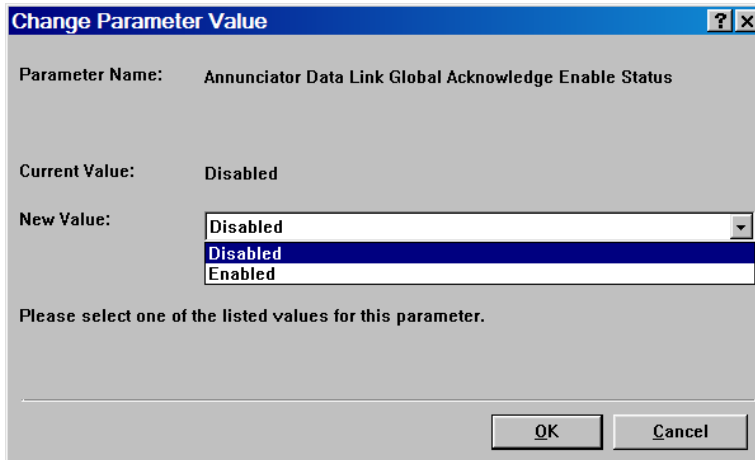

5. Select Service > LED Pair Configuration.

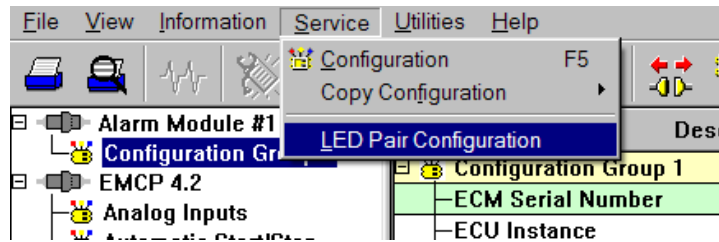

6. The LED pairs will become visible in a new window.

LED Pair#	Trigger Condition	Severity Level	Suspect Parameter Number	Failure Mode Identifier
1	Specific Event	Condition Met, Red On, Other Not Used, Horn On	Emergency Stop Shutdown [970]	
2	Specific Event	Condition Met, Red On, Other Not Used, Horn On	Engine Failure to Start Shutdown [1664]	
3	Specific Event	Low Warning	Engine Coolant Temperature [110]	
4	Specific Event	High Warning or High Shutdown	Engine Coolant Temperature [110]	
5	Specific Event	Low Warning or Low Shutdown	Engine Oil Pressure [100]	
6	Specific Event	High Shutdown	Engine Speed [190]	
7	Specific Event	Low Warning or Low Shutdown	Engine Coolant Level [111]	
8	Specific Event	Low Warning or Low Shutdown	Fuel Level [Local Tank] [96]	
9	Specific Event	Condition Met, Amber On, Other Not Used	Unknown SPN [4002]	
10	Specific Event	Condition Met, Amber On, Other Not Used, Horn On	Generator Control Not in Automatic Warning [4007]	
11	Specific Event	High Warning or High Shutdown	Battery Voltage [168]	
12	Specific Event	Low Warning	Battery Voltage [168]	
13	Specific Event	Specific Diagnostic	Battery Charging System Voltage [167]	Root Cause Not Known
14	Specific Event	Low Warning	Starting Air Pressure [82]	
15	Specific Event	Condition Met, Red On, Other Not Used, Horn On	Unknown SPN [4000]	
16	Disabled			

7. Double click on an LED pair to configure the pair.

**Change LED Pair Configuration**

LED Pair Configuration - Alarm Group #1

LED Pair#: 1

Trigger Condition: Specific Event

Severity Level: Condition Met, Red On, Other Not Used

Suspect Parameter Number: Emergency Stop Shutdown [970]

Failure Mode Identifier:

OK Cancel

8. Select the Trigger condition for the pair in the drop down menu.

**Change LED Pair Configuration**

LED Pair Configuration - Alarm Group #1

LED Pair#: 1

Trigger Condition: Specific Event (dropdown menu open showing Disabled, General Event, Specific Event)

Severity Level: Condition Met, Red On, Other Not Used

Suspect Parameter Number: Emergency Stop Shutdown [970]

Failure Mode Identifier:

OK Cancel

9. Select the Severity Level for the pair in the drop down menu.

Change LED Pair Configuration

LED Pair Configuration - Alarm Group #1

LED Pair#: 1

Trigger Condition: Specific Event

Severity Level: Condition Met, Red On, Other Not Used

Suspect Parameter Number:

Failure Mode Identifier:

Condition Met, Red On, Other Not Used  
 Condition Met, Amber On, Other Not Used, Horn On  
 Condition Met, Amber On, Red Off  
 Condition Met, Red On, Amber Off  
 Condition Met, Red On, Other Not Used  
 Condition Met, Red On, Other Not Used, Horn On  
 Condition Not Met, Amber On, Other Not Used  
 Condition Not Met, Amber On, Other Not Used, Horn On  
 Condition Not Met, Red On, Other Not Used  
 Condition Not Met, Red On, Other Not Used, Horn On

10. Select the Suspect Parameter Number for the pair in the drop down menu.

Change LED Pair Configuration

LED Pair Configuration - Alarm Group #1

LED Pair#: 1

Trigger Condition: Specific Event

Severity Level: Condition Met, Red On, Other Not Used

Suspect Parameter Number: Emergency Stop Shutdown [970]

Failure Mode Identifier:

Accessory Data Link Fault (J1939 #2) [1231]  
 Emergency Shutdown Override Mode Active Warning [1237]  
 Emergency Stop Shutdown [970]  
 Engine Failure to Start Shutdown [1664]  
 Fuel Tank Leak [1239]  
 Generator Control Not in Automatic Warning [4007]

11. The Failure Mode Identifier does not normally need to be programmed since the Severity Level typically has this information embedded.

To configure the behavior of the LED pairs, enter the LED Pair Configuration screen by selecting Service → LED Pair Configuration.

Each LED pair has four parameters associated with it. Each parameter is dependent on the parameter(s) preceding it (to the left); first Trigger Condition, next Severity Level, then Suspect Parameter Number, and finally Failure Mode Identifier (if required).

### TRIGGER CONDITION

There are three possible selections for Trigger Condition: **SPECIFIC EVENT**, **GENERAL EVENT**, and **DISABLED**.

**SPECIFIC EVENT** is used to assign an LED pair to a specific data link parameter, such as Oil Pressure, Engine Speed, Coolant Temperature, etc. The desired parameter must be chosen in the Suspect Parameter Number column.

**GENERAL EVENT** is used to assign an LED pair as a general alarm or shutdown indicator. When configured as General Event, the LED will not be assigned to a particular parameter. It will respond to any event with a severity level chosen in the Severity Level column, regardless of the Suspect Parameter Number.

For this reason, when General Event is selected, the Suspect Parameter Number cannot be changed.

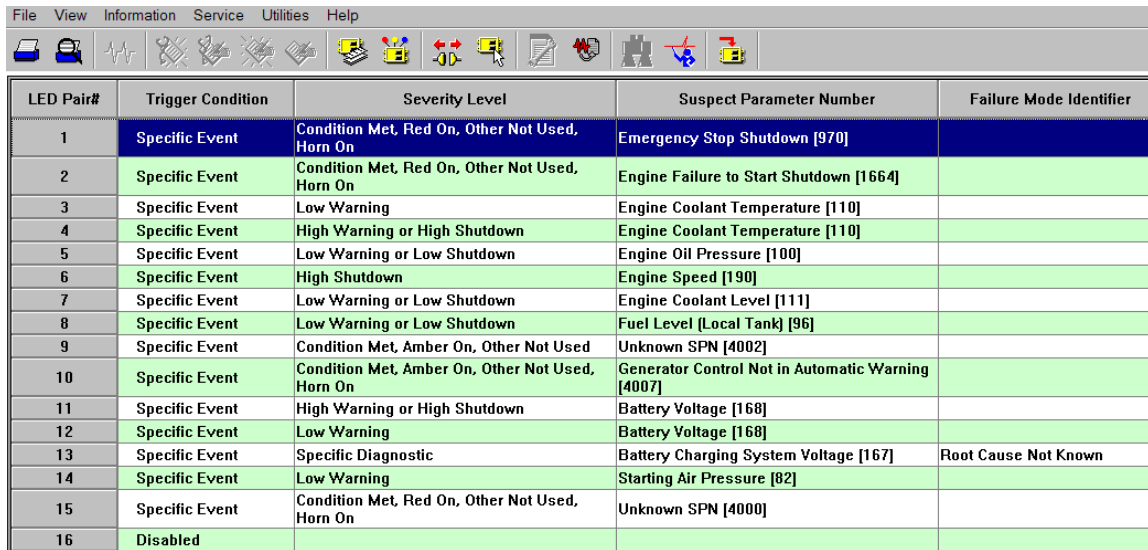

LED Pair#	Trigger Condition	Severity Level	Suspect Parameter Number	Failure Mode Identifier
1	Specific Event	Condition Met, Red On, Other Not Used, Horn On	Emergency Stop Shutdown [970]	
2	Specific Event	Condition Met, Red On, Other Not Used, Horn On	Engine Failure to Start Shutdown [1664]	
3	Specific Event	Low Warning	Engine Coolant Temperature [110]	
4	Specific Event	High Warning or High Shutdown	Engine Coolant Temperature [110]	
5	Specific Event	Low Warning or Low Shutdown	Engine Oil Pressure [100]	
6	Specific Event	High Shutdown	Engine Speed [190]	
7	Specific Event	Low Warning or Low Shutdown	Engine Coolant Level [111]	
8	Specific Event	Low Warning or Low Shutdown	Fuel Level (Local Tank) [96]	
9	Specific Event	Condition Met, Amber On, Other Not Used	Unknown SPN [4002]	
10	Specific Event	Condition Met, Amber On, Other Not Used, Horn On	Generator Control Not in Automatic Warning [4007]	
11	Specific Event	High Warning or High Shutdown	Battery Voltage [168]	
12	Specific Event	Low Warning	Battery Voltage [168]	
13	Specific Event	Specific Diagnostic	Battery Charging System Voltage [167]	Root Cause Not Known
14	Specific Event	Low Warning	Starting Air Pressure [82]	
15	Specific Event	Condition Met, Red On, Other Not Used, Horn On	Unknown SPN [4000]	
16	Disabled			

**Figure 39: Cat Service Tool CAN 2 Annunciator Led Configuration Screen**

**DISABLED** is used to disable the LED pair. When Disabled is selected, the other three parameters cannot be changed.

### SEVERITY LEVEL

Severity Level defines which types of events the LED pair will react to. Selections that begin with Condition Exists will respond to CAN Event messages for Failure Mode Identifier (FMI) 31 Condition Exists.

For example, LED pair #2 is configured for Condition Exists, Red On, Other Not Used, Horn On with SPN 190 (Emergency Stop Active). This means that when the Annunciator received a CAN message indicating Emergency Stop with FMI 31, the Red LED will turn on and the Horn will also turn on.

Other Not Used indicates that the other LED color in the pair is never used.

Green Off (for example) indicates that the green LED lights when the condition chosen for this LED pair is NOT active.

Most Severity Level selections imply (a) CAN Failure Mode Identifier (FMI) code(s):

**CONDITION EXISTS** is equivalent to FMI 31

**HIGH WARNING** can be FMI 15 or FMI 16

**LOW WARNING** can be FMI 17 or FMI 18

**HIGH SHUTDOWN** is equivalent to FMI 0

**LOW SHUTDOWN** is equivalent to FMI 1

**HIGH OR LOW SHUTDOWN** is equivalent to FMI 0 or FMI 1

Since the FMI codes are implied by this column, the FMI column is grayed out for any of these selections.

The only option that will allow an FMI to be configured is **SPECIFIC DIAGNOSTIC**.

### SUSPECT PARAMETER NUMBER

The Suspect Parameter Number column is used to select or type in the SPN for the parameter assigned to the LED pair. Most supported SPNs can be selected from the list. Refer to the UENR1209 Systems Operation Testing and Adjusting Manual for a complete list of supported SPNs.

## 17.2 RS-485 ANNUNCIATOR (EMCP 4.2 ONLY)

The EMCP RS-485 Annunciator serves to display system alarm conditions and status indications. The RS-485 Annunciator has been designed for use on a dedicated EMCP 4 fully isolated two wire RS-485 SCADA Data Link (Half Duplex), and may be used in either Local or Remote applications, providing customers with enhanced site flexibility. The RS-485 Annunciator uses a custom master-slave communication protocol. The EMCP 4.2 controller will be the Master, and the RS-485 Annunciator(s) will be the slave(s). Configuration takes place within the EMCP 4.

In Local application, the RS-485 Annunciator may be mounted on the Package generator set with the EMCP 4 to provide a complete package-mounted monitoring solution.

The RS-485 Annunciator may also be mounted separately from the generator set to provide Remote indication of system operating and alarm conditions.

The number of RS-485 Annunciators is limited by the RS-485 standard.



## ANNUNCIATOR FEATURES

The Annunciator includes:

Sixteen (16) LED pairs for annunciation of up to 32 system events

An additional pair of LED's provides status indication of the dedicated RS-485 Annunciator Network communication connection

Ability to annunciate alarm conditions sent from the EMCP 4 within preconfigured alarm groups

Alarm Horn with Lamp Test and Alarm Acknowledge pushbuttons

Configurable to NFPA 99/110 requirements for local and remote annunciation on Emergency Standby Generator Systems

Provides a simple means to change the labels for the annunciation LED's for site specific requirements (Custom Label provided with Custom Alarm Group #1 and #2 RS-485 Annunciator)

Superior visibility of the LED's in direct sunlight

Graphic symbols along with text labels are provided next to each LED pair to indicate various alarms and events

Configurable with Cat ET via settings within the EMCP 4

Can be mounted either locally on the package generator set or remotely (up to 4000 feet)

Designed and tested to meet stringent Impulse Shock and Operating Vibration requirements

286 mm (11.26 in) High x 157 mm (6.18 in) Wide x 68 mm (2.67 in) Deep

## ANNUNCIATOR SPECIFICATIONS

### ELECTRICAL SPECIFICATIONS

Control Power 12 VDC & 24 VDC nominal (9 – 32 VDC acceptable)

Reverse voltage capability is -32 VDC for 1 hour @ 70°C

Over voltage capability is 80 VDC for 2 minutes @ 70°C

Single, 8-pin connector provides both power and communication

Designed to meet relevant European standards for EMI/RFI/Immunity without the use of external filtering

### ENVIRONMENTAL SPECIFICATIONS

Operating Temperature -40 to 70°C

Storage Temperature -50°C to +85°C

Relative Humidity 90%, non-condensing, 30°C to 60°C.

Failure Point 85°C. If the ambient temperature were to exceed 85°C, the device would **NOT** be expected to return to proper operation.

Can be mounted directly on the generator set panel or remotely

**NETWORK COMMUNICATIONS INTERFACE**

EMCP 4 provides a dedicated, fully isolated RS-485 SCADA Data Link (Half Duplex) separate from the RS-485 (MODBUS) port used on the EMCP 4

Operates at 19200 bits per second

Configuration is accomplished with the Cat Service Tool by connecting to the EMCP 4

**RS-485 ANNUNCIATOR WIRING**

The back of the RS-485 Annunciator module contains an 8-terminal screw terminal block. Attached to the block is an 8-pin Deutsch receptacle, Cat part number 3E-3388 (Deutsch DT04-08PA-E005). The mating plug is Cat part number 155-2264 (Deutsch DT06-08SA-EP08, or equivalent). The pin outs for both the receptacle and terminal block are shown in Figure 40 and Table 18 and 19.

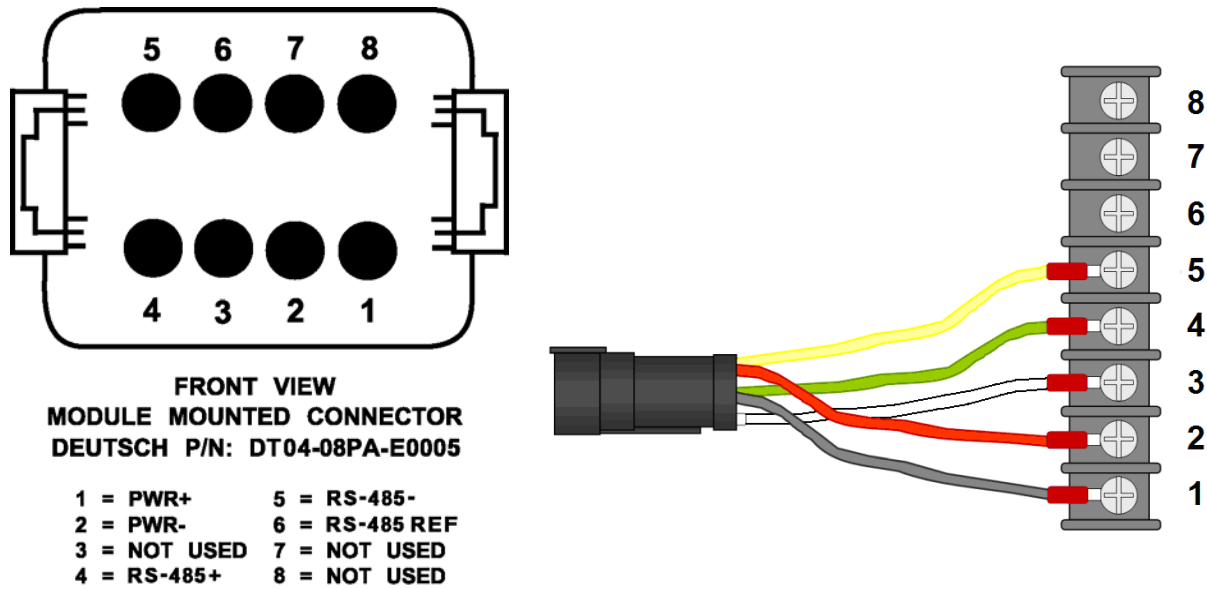

**Figure 40: RS-485 Annunciator Deutsch Connector Pin Configuration and Terminal Block**

RS-485 ANNUNCIATOR DEUTSCH CONNECTOR PIN CONFIGURATION		
Pin #	Function	Comments
1	BATT +	+ Battery input
2	BATT -	- Battery input
3	NA	NA
4	RS-485 B (+)	+ Non-Inverting Positive RS-485 input signal
5	RS-485 A (-)	- Inverting Negative RS-485 input signal
6	RS-485 R	RS-485 Reference
7	NA	NA
8	NA	NA

**Table 18: RS-485 Annunciator Deutsch Connector Pin Configuration**

RS-485 ANNUNCIATOR TERMINAL BLOCK PIN CONFIGURATION		
Terminal #	Function	Description
1	BATT -	- Battery input
2	BATT +	+ Battery input
3	RS-485 R	RS-485 Reference
4	RS-485 B (+)	+ Non-Inverting Positive RS-485 input signal
5	RS-485 A (-)	- Inverting Negative RS-485 input signal
6	Lamp Test SW	Lamp Test
7	Alarm ACK	Alarm Acknowledge
8	Horn Drive	Connects to negative terminal on Horn

**Table 19: RS-485 Annunciator Terminal Block Pin Configuration**

**LED COLORS**

Each pair of LED's on the RS-485 Annunciator consists of two of the following three colors: Green, Amber, and Red, which allows for custom configuration of **STATUS**, **WARNING** and **SHUTDOWN** conditions. The available colors and combinations are listed in Table 20 LED Colors:

LED COLORS					
ROW	LED 1	LED 2	ROW	LED 1	LED 2
1	Red	Amber	9	Red	Amber
2	Red	Amber	10	Red	Amber
3	Red	Amber	11	Red	Amber
4	Red	Amber	12	Red	Amber
5	Red	Amber	13	Green	Amber
6	Red	Green	14	Green	Amber
7	Red	Amber	15	Red	Green
8	Red	Amber	16	Red	Amber

**Table 20: LED Colors**

**MODULE STATUS LED**

A red/green pair located at the bottom of the RS-485 Annunciator, is used to report Module/Network Status. The various states indicated are explained in Table 21.

BEHAVIOR	EXPLANATION
Red solid	Data link diagnostic. For example: the module is wired wrong (Data Link), or no terminating resistor.
Green solid	Data is being received from the EMCP 4
Green flashing	Loss of communication
Red/Green flashing	No application software loaded, or Alarm Group Selection Mode is active

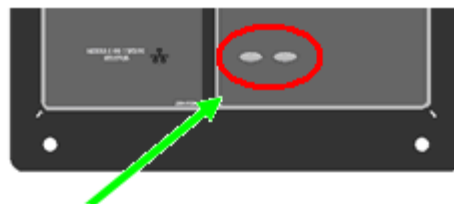

**Table 21: Annunciator Module / Network Status LED Behavior**

## LAMP TEST FUNCTION

The Annunciator supports a lamp test function from a button press on the EMCP 4.

The lamp test function cycles continuously through two test modes while pressing and holding in the Lamp Test button. The first mode is a column test mode. The left column of LED's will be lit for one second while the right column is off. Then the right column of LED's will be lit for one second, while the left column is off. This will occur twice.

During the second run of this test mode (during the first cycle only), the horn will be on.

The second test mode is an individual LED test mode. In this mode, the LED's will light one at a time, starting from the top left LED, down to the left hand module status LED, then over to the right hand module status LED, then up to the top right LED. Each LED will be lit for 1/2 second, after which it will turn off and the next LED will be lit. At the completion of this test mode, the cycle will restart with the first test mode. However, on subsequent runs of the first test mode, the horn will not turn on.

The RS-485 Annunciator returns to normal operation once the lamp test button is released.

## ALARM ACKNOWLEDGE

The RS-485 Annunciator supports an acknowledge event/silence horn function from a button press on the RS-485 Annunciator or from the EMCP 4. Both cases have different behavior and are outlined below.

When an active event is received from the EMCP 4 and is acknowledged locally with a button press on the RS-485 Annunciator module, any flashing LED tied to that event will stop flashing and maintain a steady illumination and the horn will be silenced.

**Note:** Only the local RS-485 Annunciator module that acknowledges the active event will change the state of its flashing LED(s) and silence the horn. The acknowledge signal of the annunciation is not broadcast to any other units on the RS-485 Annunciator Data Link.

When an active event is received from the EMCP 4 and is acknowledged globally with a button press on the EMCP 4 controller, it is transmitted to the RS-485 Annunciator(s) module(s). Any flashing LED tied to that event will stop flashing and maintain a steady illumination and the horn will be silenced.

**Note:** In this case, the EMCP 4 may acknowledge active events on multiple RS-485 Annunciators simultaneously.

The horn silence / acknowledge function will cause the local horn to be silenced until another event causes an LED to be activated.

### **RS-485 ANNUNCIATOR ALARM GROUPS**

The RS-485 Annunciator supports four different Alarm Groups. Alarm Group 01, 02, 03, and Alarm Group 04. Two of these Alarm Groups, 03 and 04, are fixed and are not configurable and two Alarm Groups, 01 and 02, are reserved for custom event settings and are fully configurable.

Selecting which of the four Alarm Groups to configure the RS-485 Annunciator is determined by the film that is placed on the front left panel. The Alarm Groups and the events that make up the films for each of the Alarm Groups are detailed below in Tables 23, 24 and 25. Configuring the RS-485 Annunciator to one of the four Alarm Groups is accomplished through the front panel of the RS-485 Annunciator and is described further in Alarm Group Selection Mode below.

### **ALARM GROUP SELECTION MODE (AGSM)**

The RS-485 Annunciator supports an Alarm Group Selection Mode (AGSM) that provides the ability to configure the RS-485 Annunciator to monitor a predetermined set of 32 events communicated by the EMCP 4 through the dedicated RS-485 Annunciator Data Link.

Alarm Group selection and assignment are determined by the desired functions of the RS-485 Annunciator (Custom or non-configurable) and the film that is placed on the front left panel that reflects the predefined events monitored by the RS-485 Annunciator. When in AGSM, the top first four rows of LED's will indicate which Alarm Group the RS-485 Annunciator has been assigned to by powering 'on' both LED's in each row, i.e. row 1 for Alarm Group 01, row 2 for Alarm Group 02, row 3 for Alarm Group 03, and row 4 for Alarm Group 04. (**Note:** The RS-485 Annunciator will be preprogrammed to Alarm Group 04.)

The RS-485 Annunciator will continue to communicate to the EMCP 4 while in AGSM. Events received from the EMCP 4 while in AGSM will not be annunciated until AGSM has been exited only if the event that is received is an event in the selected Alarm Group.

Once the RS-485 Annunciator has successfully been assigned to an Alarm Group, it shall receive and process any Event transmitted from the EMCP 4 to the assigned Alarm Group without power cycling the module.

The Network Status LED's will alternate flashing at a 2Hz rate at all times while in AGSM.

### **ENTERING AGSM**

The RS-485 Annunciator shall enter AGSM by depressing the two buttons on the front panel of the RS-485 Annunciator (Lamp Test and Alarm ACK) for 3 seconds. The RS-485 Annunciator shall acknowledge entrance of AGSM by flashing the top 4 rows of LED's 4 times at a 1 second rate.

After the 3 second period has timed out, the row representing the currently assigned alarm group address will be powered on, the remaining 11 rows of LED's will not be powered on. See Table 22 AGSM LED Behavior below.

Row	Column 1	Column 2
1	Solid if Assigned to Alarm Group 01, else off	Solid if Selected to Alarm Group 01, else off
2	Solid if Assigned to Alarm Group 02, else off	Solid if Selected to Alarm Group 02, else off
3	Solid if Assigned to Alarm Group 03, else off	Solid if Selected to Alarm Group 03, else off
4	Solid if Assigned to Alarm Group 04, else off	Solid if Selected to Alarm Group 04, else off
5	Off	Off
6	Off	Off
7	Off	Off
8	Off	Off
9	Off	Off
10	Off	Off
11	Off	Off
12	Off	Off
13	Off	Off
14	Off	Off
15	Off	Off
16	Off	Off

**Table 22: AGSM LED Behavior**

### RE-CONFIGURING/SELECTING ALARM GROUP ADDRESS

While the RS-485 Annunciator is still in AGSM it will cycle through the four Alarm Groups by pressing one of the two buttons on the front panel. Pressing the Lamp Test button will cycle up through the 4 Alarm Groups and pressing the Alarm ACK button will cycle down through the 4 Alarm Groups.

Upon reaching Alarm Group 04 (row 4) while cycling down through the Alarm Groups with the Alarm ACK button, an additional Alarm ACK button press will bring the selection to Alarm Group 01 (row 1). Upon reaching the Alarm Group 01 (row 1) while cycling up through the Alarm Groups with the Lamp Test button, an additional Lamp Test button press will bring the selection to Alarm Group 04 (row 4).

When selecting a new Alarm Group address, the left column (red LED) will represent the previously configured Alarm Group selection. The right column (amber LED) will represent the currently selected Alarm Group. When AGSM is exited, the currently selected register address will be configured as the new Alarm Group.

### EXITING AGSM

The Annunciator will exit AGSM under two possible conditions:

- A time out period without any button presses
- Pressing and holding the two buttons (ACK and Horn buttons) for 3 seconds

After a period of 15 seconds without any button presses, the RS-485 Annunciator will automatically exit AGSM and disregard any changes made to the Alarm Group selection and remain configured to the Alarm Group prior to entering AGSM.

When an Alarm Group selection has been made and the two buttons are pressed (Lamp Test and Alarm ACK) and held in continuously for 3 seconds, the RS-485 Annunciator

will update the current configured Alarm Group to the current selected Alarm Group and then exit AGSM.

After exiting AGSM under either one of the two exit conditions listed, the RS-485 Annunciator will flash all 16 rows of LED's for 3 seconds at which time the RS-485 Annunciator will enter regular annunciation mode.

### **RS-485 ANNUNCIATOR CUSTOM ALARM GROUP CONFIGURATION**

The RS-485 Annunciator is field-programmable by the EMCP 4 via the Cat Service Tool when configured for Alarm Group's 01 and 02. Alarm Group's 01 and 02 support customization of the 32 events for the 16 LED's.

The service tool software must be installed on a Windows PC. The Cat communication adapter must be connected between the PC and the CAN Primary data link on which the target EMCP 4 is connected.

### **CUSTOM ALARM GROUP SELECTION**

When the Cat Service Tool is communicating, the EMCP 4 shall be selected as the target module. Located at the top of the Cat Service Tool screen is the tool bar, select Service → RS-485 Annunciator. The RS-485 Annunciator configuration screen will be displayed with the Alarm Group Select at the top left of the screen. There are two possible selections for Alarm Groups: #1 and #2.

To configure the RS-485 Annunciator LED's, select each of the LED's individually. With the selected LED window displayed the initial selection is for Trigger Condition. There are three possible selections for Trigger Condition: **SPECIFIC EVENT**, **GENERAL EVENT**, and **Disabled**.

**SPECIFIC EVENT** is used to assign an LED pair to a specific data link parameter, such as Oil Pressure, Engine Speed, Coolant Temperature, etc. The desired parameter must be chosen in the Suspect Parameter Number column.

**GENERAL EVENT** is used to assign an LED pair as a general alarm or shutdown indicator. When configured as General Event, the LED will not be assigned to a particular parameter. It will respond to any event with a severity level chosen in the Severity Level column, regardless of the Suspect Parameter Number.

For this reason, when General Event is selected, the Suspect Parameter Number cannot be changed.

**DISABLED** is used to disable the LED pair. When Disabled option is selected, the other three parameters cannot be changed.

## SEVERITY LEVEL

Severity Level defines which types of events the LED pair will react to. Selections that begin with Condition Exists will respond to CAN Event messages for Failure Mode Identifier (FMI) 31 Condition Exists.

For example, LED pair #1 is configured for Condition Exists, Red On, Other Not Used, Horn On with SPN 190 (Emergency Stop Active). This means that when the RS-485 Annunciator receives a data from the EMCP 4 over the RS-485 Annunciator Data Link indicating Emergency Stop with FMI 31, the Red LED will turn on and the Horn will also turn on.

Other Not Used indicates that the other LED color in the pair is never used.

Green Off (for example) indicates that the green LED lights when the condition chosen for this LED pair is NOT active.

Most Severity Level selections imply (a) Failure Mode Identifier (FMI) code(s):

**CONDITION EXISTS** is equivalent to FMI 31

**HIGH WARNING** can be FMI 15 or FMI 16

**LOW WARNING** can be FMI 17 or FMI 18

**HIGH SHUTDOWN** is equivalent to FMI 0

**LOW SHUTDOWN** is equivalent to FMI 1

**HIGH OR LOW SHUTDOWN** is equivalent to FMI 0 or FMI 1

Since the FMI codes are implied by the choice made in the Severity Level column, the FMI column is grayed out for any of these selections.

The only option that will allow a specific FMI to be configured is **SPECIFIC DIAGNOSTIC**.

## SUSPECT PARAMETER NUMBER

The Suspect Parameter Number column is used to select one of the listed SPN's in the drop down menu or type in a specific SPN number for an SPN that may not be listed in the drop down menu for the parameter assigned to the LED pair. Most supported SPNs can be selected from the list.

## ENGINE RUNNING

When configuring the RS-485 Annunciator for ENGINE RUNNING, special consideration must be taken to trigger the event. The SPN shall be configured for Auxiliary I/O #1 (SPN 701) and it shall have a Severity Level configured for any one of the Condition Met setpoints. Digital Input #1 shall be physically wired to the active status signal that is to be used to trigger this programmed LED. If it is only to be based upon the status of the generator set controlled by the EMCP, then an output such as Relay Output #2, Fuel Control Relay, or Engine Start Initiated for Common Engine Interface generator sets on the EMCP 4 can be used. The Fuel Control Relay or Engine Start Initiated active status signal is continually active only while the engine is in running.

Alarm Group #3 has LED #15 pre-configured for Auxiliary I/O #1 and requires the actions above to trigger an Engine Running event on the RS-485 Annunciator.

## ALARM GROUPS

The RS-485 Annunciator is capable of being configured for one of four Alarm Groups. Two of these Alarm Groups are fixed, two are configurable. Selection of the Alarm Group to be used is accomplished by using the front panel of the RS-485 Annunciator module as explained above in Alarm Group Selection Mode (AGSM).

The assignment of films for each of the Alarm Groups is outlined below:

Alarm Group # 1 (Custom Configurable 1) - Film #1 (see Table 23) and custom film

Alarm Group # 2 (Custom Configurable 2) - Film #1 (see Table 23) and custom film

Alarm Group # 3 (Fixed) - Film #1 (see Table 23)

Alarm Group # 4 (Fixed) - Film #2, or Film #3 (see Tables 24 and 25)

**Note:** Alarm Groups #1 and #2 are blank until configured.

Row	LED Colors	Default LED and Setpoint Assignments	Horn
1	Red	E-Stop Shutdown	Y
	Amber	Not Used	NA
2	Red	Overcrank	Y
	Amber	Not Used	NA
3	Red	High Coolant Temp Shutdown	Y
	Amber	High Coolant Temp Warning	Y
4	Red	Not Used	NA
	Amber	Low Coolant Temp Warning	Y
5	Red	Low Oil Pressure Shutdown	Y
	Amber	Low Oil Pressure Warning	Y
6	Red	Overspeed Shutdown	Y
	Green	Not Used	NA
7	Red	Low Coolant Level Shutdown	Y
	Amber	Low Coolant Level Warning	Y
8	Red	Low Fuel Level Shutdown	Y
	Amber	Low Fuel Level Warning	Y
9	Red	Not Used	NA
	Amber	Generator Not in Auto Warning	Y
10	Red	High Battery Voltage Shutdown	Y
	Amber	High Battery Shutdown Warning	Y
11	Red	Not Used	NA
	Amber	Low Battery Voltage Warning	Y
12	Red	Not Used	NA
	Amber	Low Cranking Voltage Warning	Y
13	Green	Not Used	NA
	Amber	Battery Charger AC Failure	Y
14	Green	Not Used	NA
	Amber	EPS Supplying Load	N
15	Red	Not Used	NA
	Green	Engine Running	N
16	Red	SCR – Tier 4	Y
	Amber	SCR – Tier 4	Y

**Table 23: Film #1. Alarm Group 01 & 02 default film and Alarm Group 03 film assignments.**

**NFPA 99/110 events. Includes Fuel Level, Engine Running, and Tier 4 SCR events**

Row	LED Colors	Default LED and Setpoint Assignments	Horn
1	Red	E-Stop Shutdown	Y
	Amber	Not Used	NA
2	Red	Overcrank	Y
	Amber	Not Used	NA
3	Red	High Coolant Temp Shutdown	Y
	Amber	High Coolant Temp Warning	Y
4	Red	Not Used	NA
	Amber	Low Coolant Temp Warning	Y
5	Red	Low Oil Pressure Shutdown	Y
	Amber	Low Oil Pressure Warning	Y
6	Red	Overspeed Shutdown	Y
	Green	Not Used	NA
7	Red	Low Coolant Level Shutdown	Y
	Amber	Low Coolant Level Warning	Y
8	Red	Low Fuel Level Shutdown	Y
	Amber	Low Fuel Level Warning	Y
9	Red	Not Used	NA
	Amber	Generator Not in Auto Warning	Y
10	Red	High Battery Voltage Shutdown	Y
	Amber	High Battery Shutdown Warning	Y
11	Red	Not Used	NA
	Amber	Low Battery Voltage Warning	Y
12	Red	Not Used	NA
	Amber	Low Cranking Voltage Warning	Y
13	Green	Not Used	NA
	Amber	Battery Charger AC Failure	Y
14	Green	Not Used	NA
	Amber	EPS Supplying Load	N
15	Red	Air Damper Shutdown	Y
	Green	Not Used	NA
16	Red	SCR – Tier 4	Y
	Amber	SCR – Tier 4	Y

**Table 24: Film #2. Alarm Group 04. NFPA 99/110 events.**

**Includes Fuel Level, Air Damper Shutdown, and Tier 4 SCR events.**

Row	LED Colors	Default LED and Setpoint Assignments	Horn
1	Red	E-Stop Shutdown	Y
	Amber	Not Used	NA
2	Red	Overcrank	Y
	Amber	Not Used	NA
3	Red	High Coolant Temp Shutdown	Y
	Amber	High Coolant Temp Warning	Y
4	Red	Not Used	NA
	Amber	Low Coolant Temp Warning	Y
5	Red	Low Oil Pressure Shutdown	Y
	Amber	Low Oil Pressure Warning	Y
6	Red	Overspeed Shutdown	Y
	Green	Not Used	NA
7	Red	Low Coolant Level Shutdown	Y
	Amber	Low Coolant Level Warning	Y
8	Red	Low Fuel Level Shutdown	Y
	Amber	Low Fuel Level Warning	Y
9	Red	Not Used	NA
	Amber	Generator Not in Auto Warning	Y
10	Red	High Battery Voltage Shutdown	Y
	Amber	High Battery Shutdown Warning	Y
11	Red	Not Used	NA
	Amber	Low Battery Voltage Warning	Y
12	Red	Not Used	NA
	Amber	Low Cranking Voltage Warning	Y
13	Green	Not Used	NA
	Amber	Battery Charger AC Failure	Y
14	Green	Not Used	NA
	Amber	EPS Supplying Load	N
15	Red	Air Damper Shutdown	Y
	Green	Not Used	NA
16	Red	Not Used	NA
	Amber	Not Used	NA

**Table 25: Film #3. Alarm Group 04 film assignments. NFPA 99/110 events.**  
**Includes Fuel Level and Air Damper Shutdown. Does not include Tier 4 SCR**

**CONFIGURING CUSTOM ALARM GROUPS USING CAT SERVICE TOOL**

1. Connect to the EMCP 4 using the Cat Service Tool as stated in Chapter 4.2.
2. Select Service > RS-485 Annunciator Configuration.

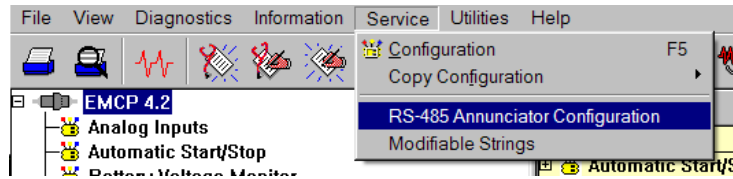

**Note:** This option will not appear if the EMCP 4 was not selected in the ECM Summary Screen when connecting to Cat ET.

3. The LED pairs will become visible in a new window.

The screenshot shows a window titled 'Select Group: Alarm Group #1'. It contains a table with the following data:

LED Pair#	Trigger Condition	Severity Level	Suspect Parameter Number	Failure Mode Identifier
1	Specific Event	Condition Met, Red On, Other Not Used	Emergency Stop Shutdown [970]	
2	Disabled			
3	Disabled			
4	Disabled			
5	Disabled			
6	Disabled			
7	Disabled			
8	Disabled			
9	Specific Event	Condition Met, Amber On, Other Not Used	Generator Control Not in Automatic Warning [4007]	
10	Disabled			
11	Disabled			
12	Disabled			
13	Disabled			
14	Disabled			
15	Disabled			
16	Disabled			

4. Select the Alarm Group for the Annunciator by choosing from the drop down menu.

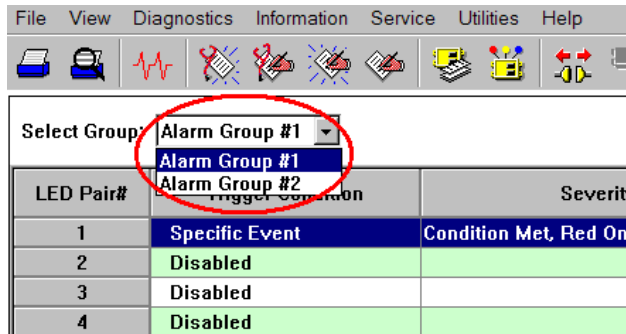

5. Double click on an LED pair to configure the pair.

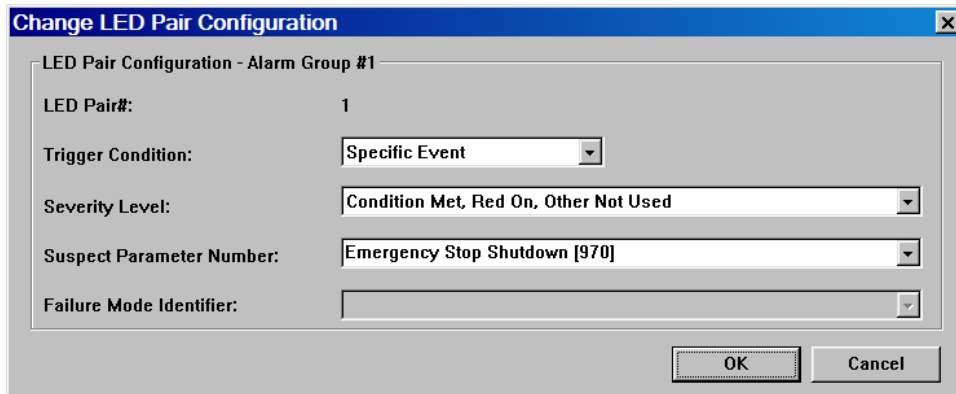

6. Select the Trigger condition for the pair in the drop down menu.

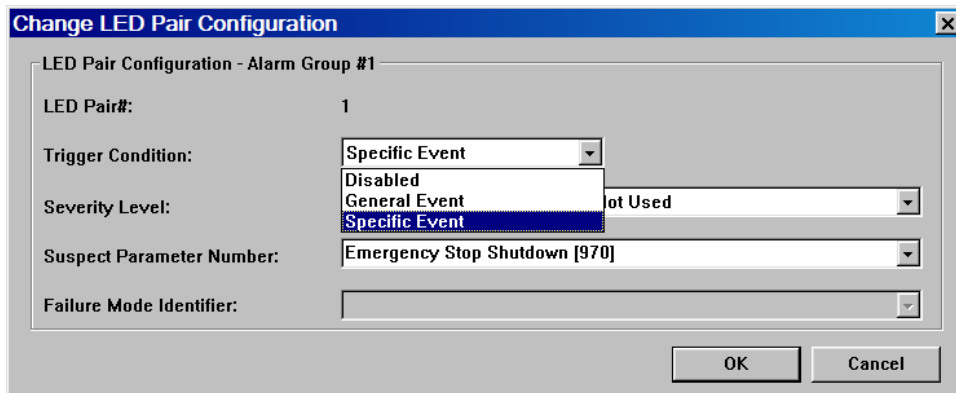

7. Select the Severity Level for the pair in the drop down menu.

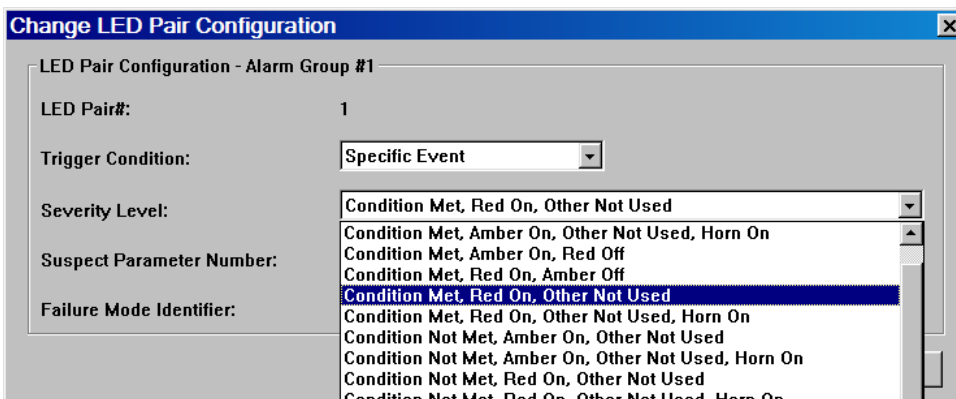

For a complete list of choices for Severity Level, see the tables below.

- Select the Suspect Parameter Number for the pair in the drop down menu.

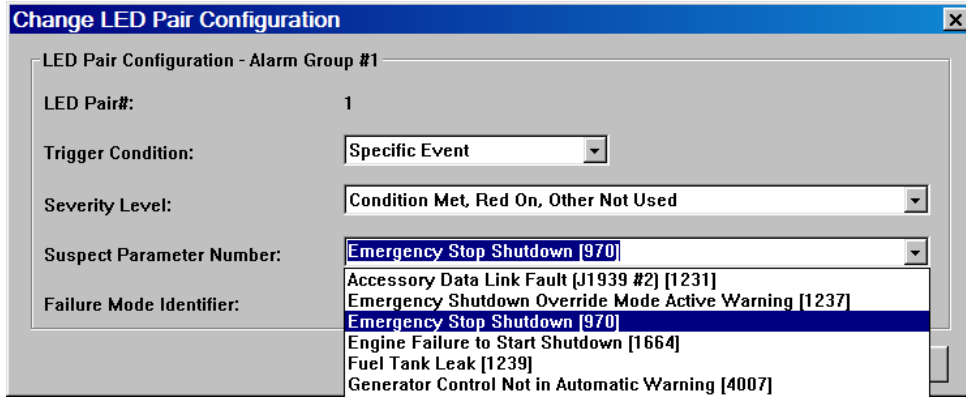

For a complete list of choices for Suspect Parameter Number, see the tables below.

- The Failure Mode Identifier does not normally need to be programmed since the Severity Level typically has this information embedded. See information below for a Diagnostic SPN.

If the LED Trigger Condition is configured as General Event, the Severity Level can be configured according to Table 26.

Trigger Condition Severity Level	Allowed for LED Pairs...		
	1-5, 7-12, 16	13-14	6, 15
Low Warning	√	√	
Low Shutdown	√		√
High Warning	√	√	
High Shutdown	√		√
High or Low Warning	√	√	
High or Low Shutdown	√		√
Low Warning or Low Shutdown	√		
High Warning or High Shutdown	√		
High or Low Warning, High or Low Shutdown	√		
High or Low Warning, High or Low Shutdown or Diagnostic	√	√	√
Diagnostic Other Than Warning / Shutdown / Condition Exists	√	√	

**Table 26: General Event Severity Levels**

If the LED Trigger Condition is configured as Specific Event, the Severity Level can be configured according to Table 27.

Trigger Condition Severity Level	Allowed for LED Pairs...		
	1-5, 7-12, 16	13-14	6, 15
Low Warning	√	√	
Low Shutdown	√		√
High Warning	√	√	
High Shutdown	√		√
High or Low Warning	√	√	
High or Low Shutdown	√		√
Low Warning or Low Shutdown	√		
High Warning or High Shutdown	√		
High or Low Warning, High or Low Shutdown	√		
High or Low Warning, High or Low Shutdown or Diagnostic	√	√	√
Diagnostic Other Than Warning / Shutdown / Condition Exists	√	√	
Specific Diagnostic	√	√	√
Condition Exists, Red On, Other Not Used	√		√
Condition Exists, Amber On, Other Not Used	√	√	
Condition Exists, Green On, Other Not Used		√	√
Condition Exists, Red On, Amber Off	√		
Condition Exists, Red On, Green Off			√
Condition Exists, Amber On, Red Off	√		
Condition Exists, Amber On, Green Off		√	
Condition Exists, Green On, Red Off			√
Condition Exists, Green On, Amber Off		√	
Condition Does Not Exist, Red On, Other Not Used	√		√
Condition Does Not Exist, Amber On, Other Not Used	√	√	
Condition Does Not Exist, Green On, Other Not Used		√	√
Condition Exists, Red On, Other Not Used, Horn On	√		√
Condition Exists, Amber On, Other Not Used, Horn On	√	√	
Condition Exists, Green On, Other Not Used, Horn On		√	√
Condition Does Not Exist, Red On, Other Not Used, Horn On	√		√
Condition Does Not Exist, Amber On, Other Not Used, Horn On	√	√	
Condition Does Not Exist, Green On, Other Not Used, Horn On		√	√

**Table 27: Specific Event Severity Levels**

For Trigger Condition Severity Level listed in the table above from 'Low Warning' to 'Specific Diagnostic' the following Suspect Parameter Number options can be used:

<b>Suspect Parameter Number Text</b>	<b>Value</b>
Fuel Level (External Tank)	38
Aftercooler Temperature	52
Starting Air Pressure	82
Fuel Filter Differential Pressure	95
Fuel Level (Local Tank)	96
Engine Oil Level	98
Oil Filter Differential Pressure	99
Engine Oil Pressure	100
Crankcase Pressure	101
Air Filter Differential Pressure	107
Barometric Pressure	108
Engine Coolant Temperature	110
Engine Coolant Level	111
Battery Voltage (switched)	158
Battery Charging System Voltage	167
Battery Voltage	168
Ambient Air Temperature	171
Inlet Air Temperature	172
Exhaust Temperature	173
Engine Oil Temperature	175
Engine Speed	190
Long Distance Annunciator Data Link Fault (Root Cause Not Known)	625
Primary Data Link Fault (Root Cause Not Known)	639
Emergency Stop Shutdown	970
Analog Input #1 Custom Parameter	1083
Analog Input #2 Custom Parameter	1084
Generator Rear Bearing Temperature	1122
Generator Front Bearing Temperature	1123
Generator Winding Temperature #1	1124
Generator Winding Temperature #2	1125
Generator Winding Temperature #3	1126
Accessory Data Link Fault (Root Cause Not Known)	1231
Unexpected Engine Shutdown (Root Cause Not Known)	1383
Right Exhaust Temperature	2433
Left Exhaust Temperature	2434
Generator Frequency	2436

<b>Suspect Parameter Number Text</b>	<b>Value</b>
Generator AC Voltage	2440
Generator AC Current	2448
Generator Real Power (kW)	2452
Generator Reactive Power (kVAr)	2456
Generator to Bus Synchronization Failure (Low)	2529
Dead Bus Arbitration Failure (Low)	2530
Engine Controller (Abnormal Update Rate)	3543
Modbus Data Link	3581
Generator Breaker Closed	4004
Generator Breaker Open	4013
Utility to Generator Transfer Failure (High)	4015
Analog Input #4 Custom Parameter	4157
Analog Input #3 Custom Parameter	4158
Cranking Voltage	4256

For the Trigger Condition Severity Levels listed in the table above from 'Condition Exists, Red On, other Not Used' to 'Condition Does Not Exist, Green On, other Not used, Horn On' the following Suspect Parameter Number options can be used:

<b>Suspect Parameter Number Text</b>	<b>Value</b>
Digital Input # 1 Custom Event	701
Digital Input # 2 Custom Event	702
Digital Input # 3 Custom Event	703
Digital Input # 4 Custom Event	704
Digital Input # 5 Custom Event	705
Digital Input # 6 Custom Event	706
Digital Input # 7 Custom Event	707
Digital Input # 8 Custom Event	708
Isolated Digital Input #1 Custom Event	3920
Isolated Digital Input #2 Custom Event	3921
Isolated Digital Input #3 Custom Event	3922
Isolated Digital Input #4 Custom Event	3923
Emergency Stop Shutdown	970
Emergency Shutdown Override Mode Active	1237
Fuel Tank Leak	1239
Engine Failure to Start	1664
Service Interval Warning	2648
Generator Unavailable to Start/Run	3677
EPS Supplying Load	3829
Air Damper Closed	4000
ATS in Normal Position	4001
ATS in Emergency Position	4002
Battery Charger Failure	4003
Generator Breaker Closed	4004
Utility Breaker Closed	4005
Engine in Cooldown	4006
Generator Control Not in Automatic Warning	4007
Generator Breaker Failure to Open	4009
Generator Breaker Failure to Close	4011
Generator Breaker Open	4013
Loss of Utility	4017
Generator Breaker Locked Out	4018
Utility Breaker Locked Out	4019
Bus Phase Sequence Incorrect	4024
Generator Phase Sequence Incorrect	4025
Earth Fault	4028
Earth Leakage	4029

If the Trigger Condition Severity Level is programmed for Diagnostic, then the Failure Mode Identifier for any pair of LED's can be configured as any of the following:

Data Erratic, Intermittent, or Incorrect	Abnormal Rate of Change
Voltage Above Normal, or Shorted to High Source	Root Cause Not Known
Voltage Below Normal, or Shorted to Low Source	Bad Intelligent Device or Component
Current Below Normal or Open Circuit	Out Of Calibration
Current Above Normal or Grounded Circuit	Special Instructions
Mechanical System Not Responding or Out of Adjustment	Received Network Data In Error
Abnormal Frequency or Pulse Width or Period	Data Drifted High
Abnormal Update Rate	Data Drifted Low

### 17.3 THERMOCOUPLE MODULE (EMCP 4.2 ONLY)

#### THERMOCOUPLE FEATURES

Reads up to 20 Type J or K thermocouple inputs

Temperatures are configured to indicate the SAE J1939 SPN to be transmitted by that temperature input. Suspect Parameter Numbers (SPNs) for configuration of temperature inputs are customer specific. Resolution: One byte parameters have a resolution of 1 °C / bit and a range of -40 °C to 210 °C. Two byte parameters have resolution of 0.03125 °C / bit and a range of -273 °C to 1735 °C

Cold junction compensation is provided

System throughput has all 20 channels scanned in 2 seconds (100 ms/channel)

Overall drift with temperature is 0.015% / °C of span (maximum)

Module is fully functional during configuration and communications

Parameter values and diagnostic error codes are retained when the modules are de-energized

Open-circuit and short-circuit diagnostics are supported

Can be mounted directly on the generator set panel or remotely

Suitable for moist, high shock and vibration environments

Compact size (see mechanical drawing, Figure 41).



## **THERMOCOUPLE SPECIFICATIONS**

### **ELECTRICAL SPECIFICATIONS**

Accept 5-32 VDC power (12 or 24 VDC nominal)

Over voltage capability is 32 VDC for 1 hour @ 85°C

Power supply inputs are protected against transient surges and short circuits and are isolated from I/O

Three way isolation is provided for the CAN line, inputs and power supply

Burden is limited to less than 200 mA; inrush not to exceed 800 mA

Common mode rejection is -80 db@ 5V p-p (50-60 Hz)

Common mode input range is +/- 4 V minimum

Designed to meet relevant European standards for EMI/RFI/Immunity without the use of external filtering

### **ENVIRONMENTAL SPECIFICATIONS**

Encapsulated in a rugged aluminum housing with watertight Deutsch connectors (IP65 rating)

Operating temperature range -40 to 85°C (-40 to 185°F) (for ambient temperatures exceeding 85°C, the temperature scanner may deviate in accuracy an additional  $\pm 1^\circ\text{C}$ )

The ambient storage temperature range is -50°C to +120°C

It is protected against 95% humidity non-condensing, 30°C to 60°C

### **NETWORK COMMUNICATIONS INTERFACE**

Capable of operating on the EMCP 4 Accessory CAN (2) data link

Node address is auto configurable

Optical isolation is provided for the CAN line

Retains current date and time relative to synchronization every 24 hours (or upon boot up) with equipment system time via an explicit command from the EMCP 4 or Service Tool when the GSC is not available; synchronization time is accurate to within 1 second

Includes a watchdog timer to atomically reboot should the microprocessor lock

Module operates normally with loss of communication link, retaining configured values and error codes in non-volatile memory

Configuration and firmware updates are accomplished with the Cat Service Tool over the CAN network

**THERMOCOUPLE WIRING**

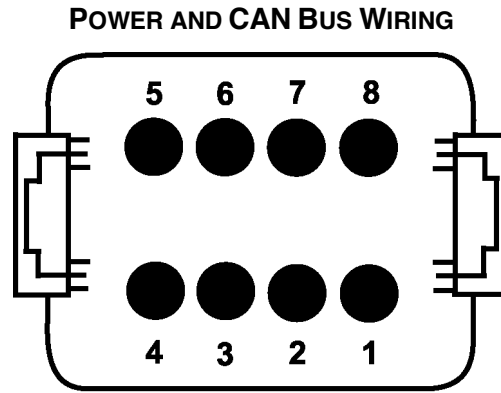

**FRONT VIEW  
MODULE MOUNTED CONNECTOR  
DEUTSCH P/N: DT13-08PA**

- 1 = PWR+      5 = SHIELD
- 2 = CAN-H    6,7,8 = NOT USED
- 3 = CAN-L
- 4 = PWR-

**THERMOCOUPLE SENSOR WIRING**

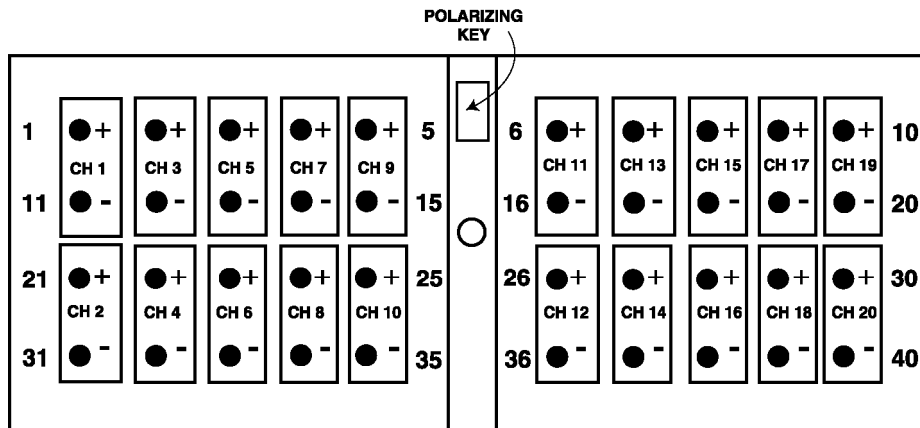

**FRONT VIEW OF  
MODULE MOUNTED CONNECTOR  
DEUTSCH P/N: DRC13-40PA**

**THERMOCOUPLE PHYSICAL LAYOUT**

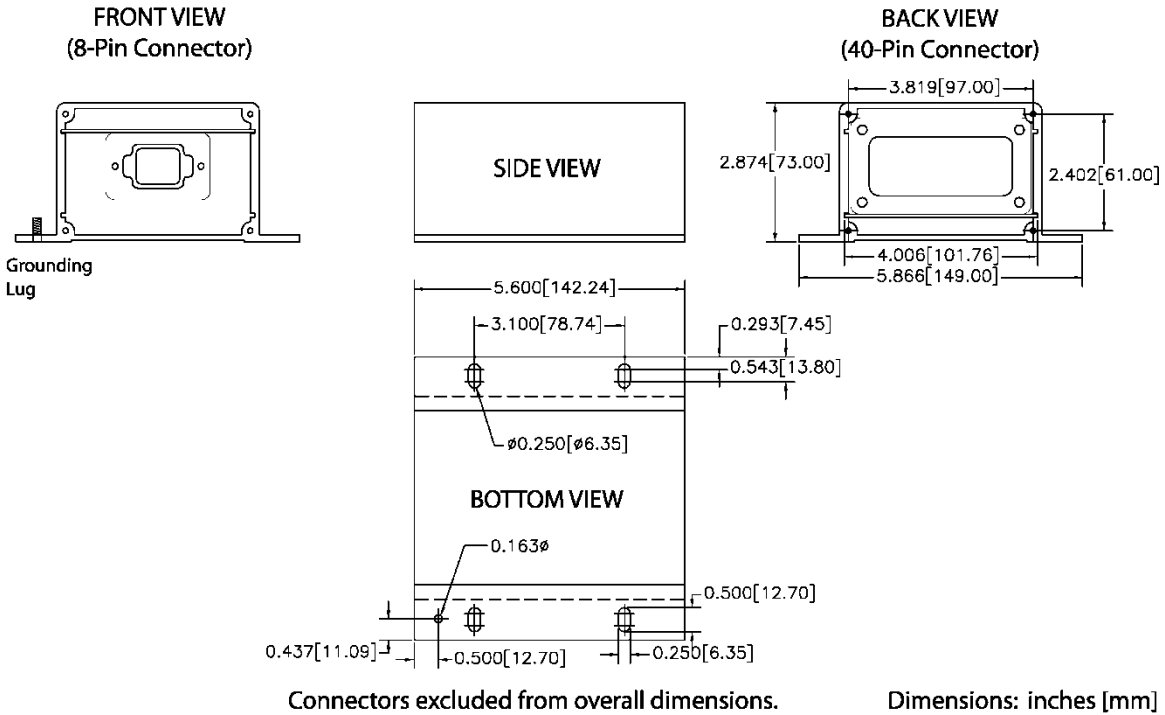
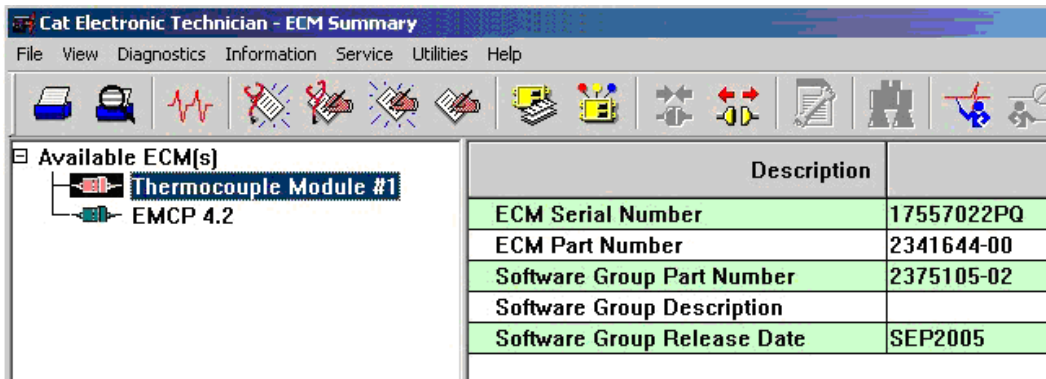

**Figure 41: Thermocouple, RTD, And Discrete I/O Module Physical Layout**

**THERMOCOUPLE MODULE – CONFIGURATION**

The Thermocouple module is field programmable using the Cat Service Tool. It is also flash programmable to update software using the Cat Service Tool.

The service tool software must be installed on a Windows PC. The Cat communication adapter must be connected between the PC and the CAN data link on which the target Thermocouple module is connected. When connecting the Thermocouple module, the user will first see the Module Summary screen shown in Figure 42.

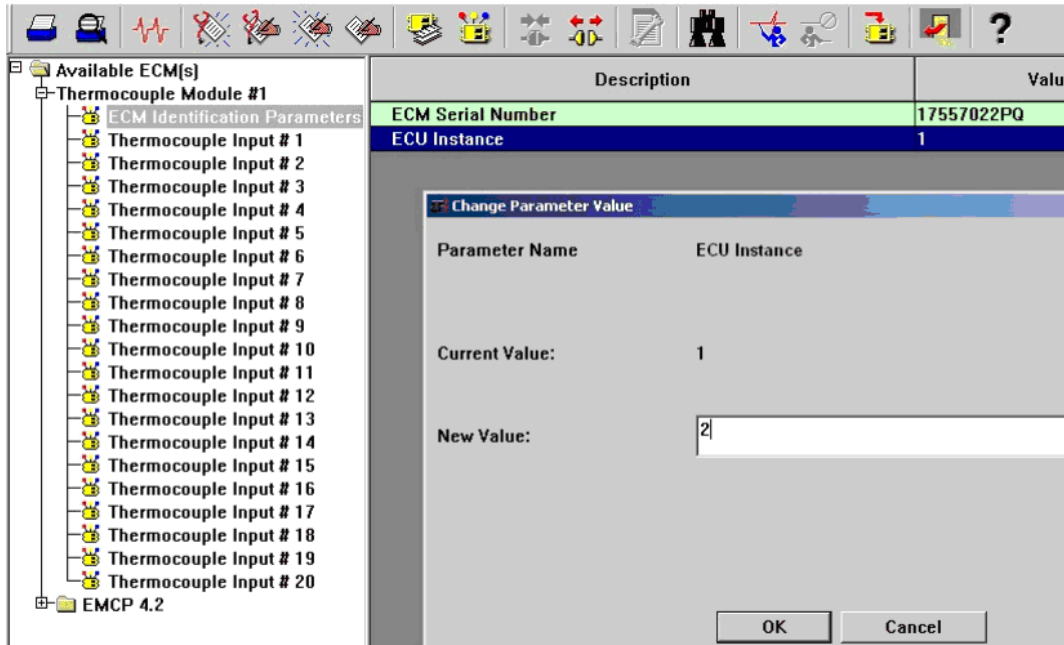

**Figure 42: Cat Service Tool Thermocouple Module Summary Screen**

The service tool configuration tool contains setpoints for configuring the Thermocouple module identification, as well as the thermocouple inputs.

Figure 43 shows the ECM Identification Parameters list. This list shows the ECM serial number (read-only) of the module that is connected, and allows for configuration of the ECU instance. Each thermocouple module on the data link must have a unique ECU instance. If ECU instances are duplicated, one of the modules must be disconnected and the other reconfigured to a different ECU instance.

**Note:** ECU Instance #1 is reserved for the Accessory Data Link (CAN 2), while ECU Instance #2 is reserved for the Primary Data Link (CAN 1).



**Figure 43: Cat Service Tool Thermocouple Module Identification Parameters**

Upon changing the ECU instance, the Cat Service Tool will automatically reconnect to the data link, and the Thermocouple module name should reflect the new ECU instance. In this example, as shown in Figure 44, the module was previously named Thermocouple Module #1, and after the ECU instance is changed to 2 and the service tool reconnects, the name reads Thermocouple Module #2.

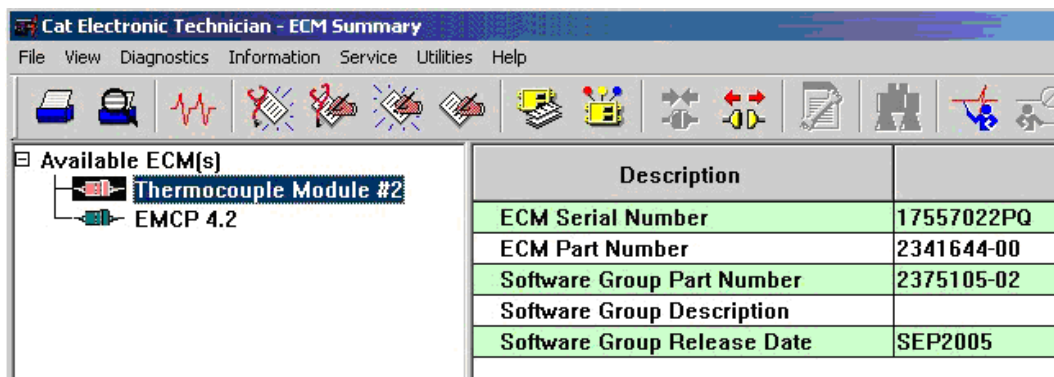

**Figure 44: Cat Service Tool Thermocouple Module After ECU Instance Change**

### CONFIGURING THERMOCOUPLE INPUTS

Figure 45 shows the **THERMOCOUPLE INPUT #1** Configuration list, when using the Cat Service Tool. All twenty thermocouple inputs have identical parameters and options.

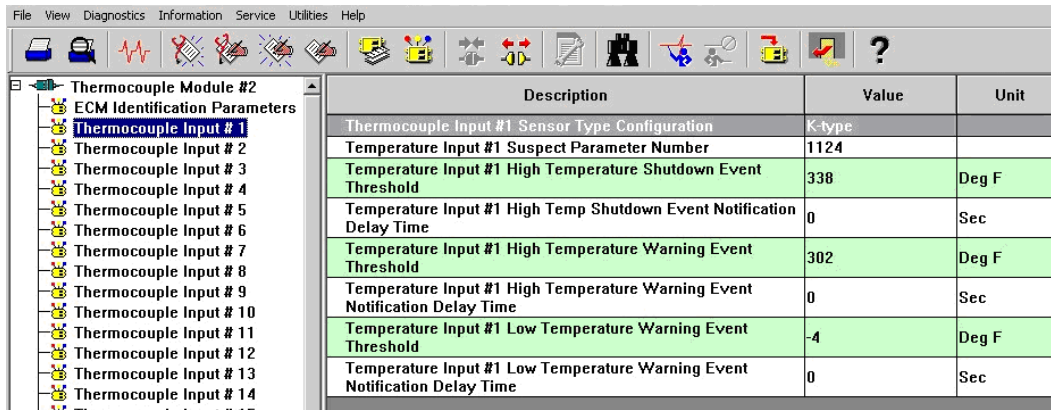

**Figure 45: Cat Service Tool Thermocouple Input Configuration**

The **SENSOR TYPE CONFIGURATION** selects either a J or K type configuration. Select the appropriate configuration based on the type of thermocouple installed. Reference the TC Module specsheet (LEHE0126) for available Temperature Inputs.

The **SUSPECT PARAMETER NUMBER (SPN)** is a numerical entry between a predetermined list of SPNs that are supported by the Thermocouple module. All of the thermocouple inputs support the same list of SPNs. To change the SPN, type in the number that corresponds with the desired parameter as shown in Figure 46. See UENR1209 for specific information on what possible SPN values can be used.

The **HIGH TEMPERATURE SHUTDOWN EVENT THRESHOLD** sets the high temperature at which a high shutdown event will occur.

The **HIGH TEMPERATURE WARNING EVENT THRESHOLD** sets the high temperature at which a high warning event will occur.

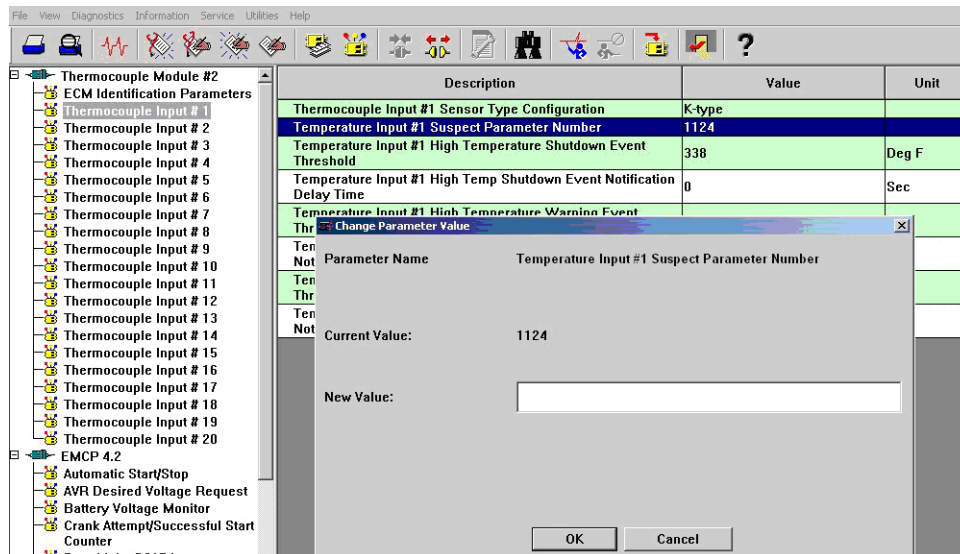

**Figure 46: Cat Service Tool Thermocouple Module Suspect Parameter Number**

The **LOW TEMPERATURE WARNING EVENT THRESHOLD** sets the low temperature at which a low warning event will occur.

The **EVENT NOTIFICATION DELAY TIME** sets the amount of time the threshold must be exceeded until the Thermocouple module triggers that particular event on the data link. Each of the delay time options corresponds with a particular event type.

## 17.4 RTD MODULE (EMCP 4.2 ONLY)

### RTD FEATURES

Reads up to eight (8) Platinum RTD inputs with 2, 3, and 4 wire configurations

System throughput has all 8 channels scanned in 2 seconds (250 ms/channel)

Overall drift with temperature is 15mOhm/°C (maximum)

Module is fully functional during configuration and communications

Parameter values and diagnostic error codes are retained when the modules are de-energized

Suitable for moist, high shock and vibration environments

Compact size (see mechanical drawing, Figure 47)



## **RTD SPECIFICATIONS**

### **ELECTRICAL SPECIFICATIONS**

Accept 5-32 VDC power (12 or 24 VDC nominal)

Over voltage capability is 32 VDC for 1 hour @ 85°C

Power supply inputs are protected against transient surges and short circuits and are isolated from I/O

Optical isolation is 500 VDC from input to ground (three way isolation is provided for the CAN line, inputs and power supply)

Burden is limited to less than 200 mA; inrush not to exceed 800 mA

Designed to meet relevant European standards for EMI/RFI/Immunity without the use of external filtering

### **ENVIRONMENTAL SPECIFICATIONS**

Encapsulated in a rugged aluminum housing with watertight Deutsch connectors (IP65 rating)

Operating temperature range -40 to 85°C (-40 to 185°F) (for ambient temperatures exceeding 85°C, the temperature scanner may deviate in accuracy an additional  $\pm 1^\circ\text{C}$ )

The ambient storage temperature range is -50°C to +120°C

It is protected against 95% humidity non-condensing, 30°C to 60°C

### **NETWORK COMMUNICATIONS INTERFACE**

Operates on the EMCP 4 Accessory CAN Data Links

Node address is auto configurable

Optical isolation is provided for the CAN line

Retains current date and time relative to synchronization every 24 hours (or upon boot up) with equipment system time via an explicit command from the EMCP 4 or Service Tool when the GSC is not available; synchronization time is accurate to within 1 second

Includes a watchdog timer to automatically reboot should the microprocessor lock

Module operates normally with loss of communication link, retaining configured values and error codes in non-volatile memory

Configuration and firmware updates are accomplished with the Cat Service Tool over the CAN network

**RTD WIRING**

**POWER AND CAN BUS WIRING**

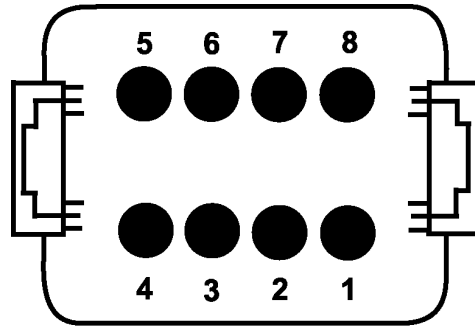

**FRONT VIEW  
MODULE MOUNTED CONNECTOR  
DEUTSCH P/N: DT13-08PA**

- 1 = PWR+    5 = SHIELD
- 2 = CAN-H    6,7,8 = NOT USED
- 3 = CAN-L
- 4 = PWR-

**RTD SENSOR WIRING**

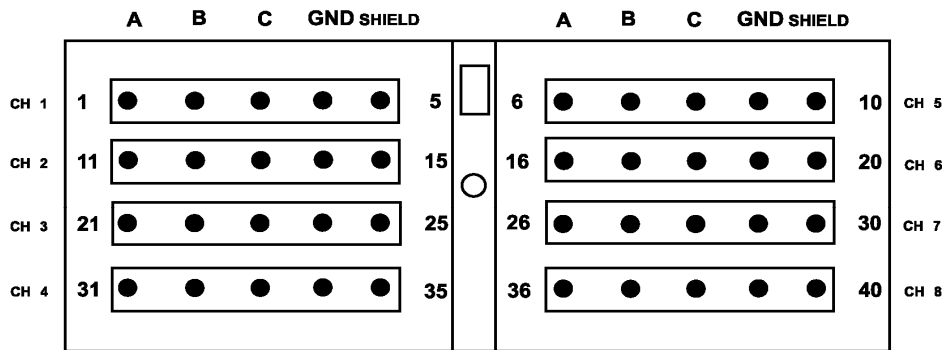

**FRONT VIEW OF  
MODULE MOUNTED CONNECTOR**

**RTD WIRING TYPICAL CONNECTIONS**

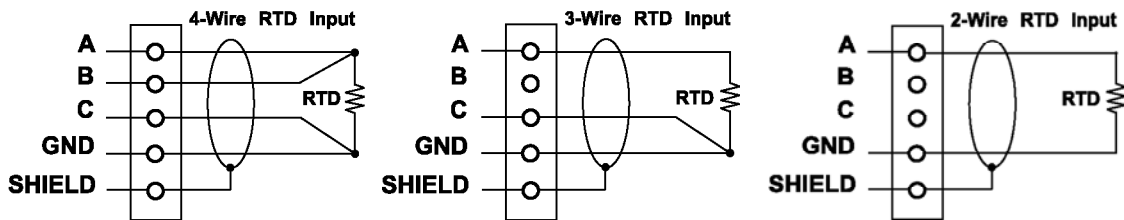

**RTD PHYSICAL LAYOUT**

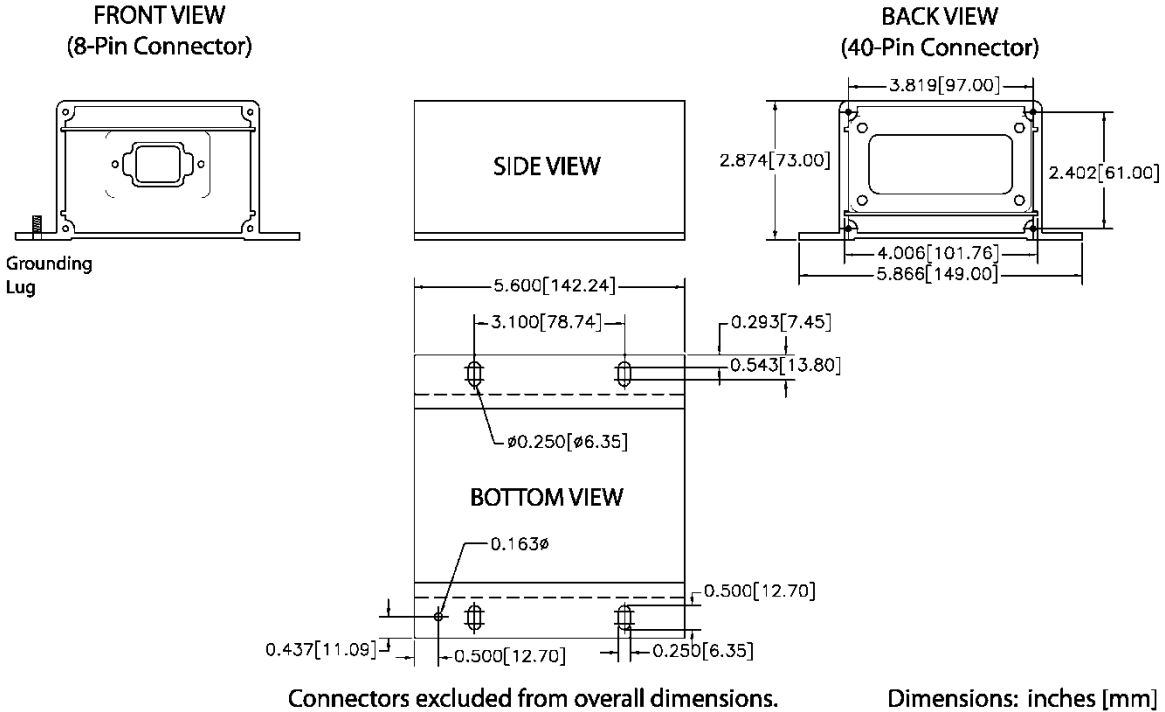

**Figure 47: Thermocouple, RTD, And Discrete I/O Module Physical Layout**

**RTD MODULE – CONFIGURATION**

The RTD (Resistance Temperature Detector) module is field programmable using the Cat Service Tool. It is also flash programmable to update software using the Cat Service Tool.

The service tool software must be installed on a Windows PC.

The Cat communication adapter must be connected between the PC and the CAN data link on which the target RTD module is connected.

When connecting to the RTD module, the user will first see the Module Summary screen shown in Figure 48.

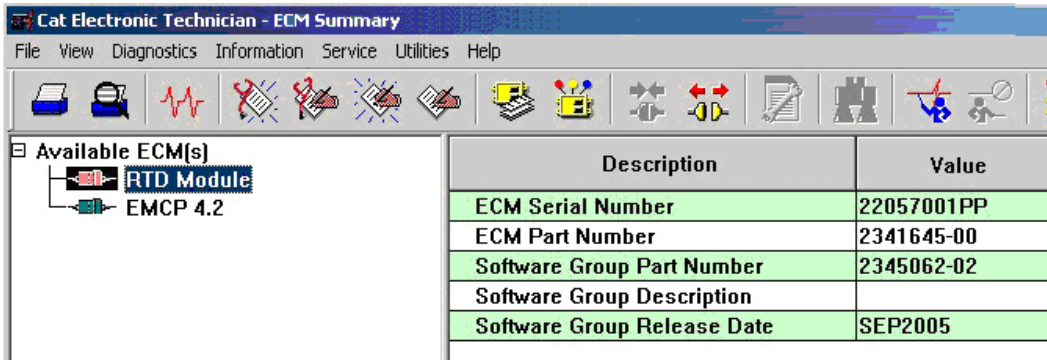
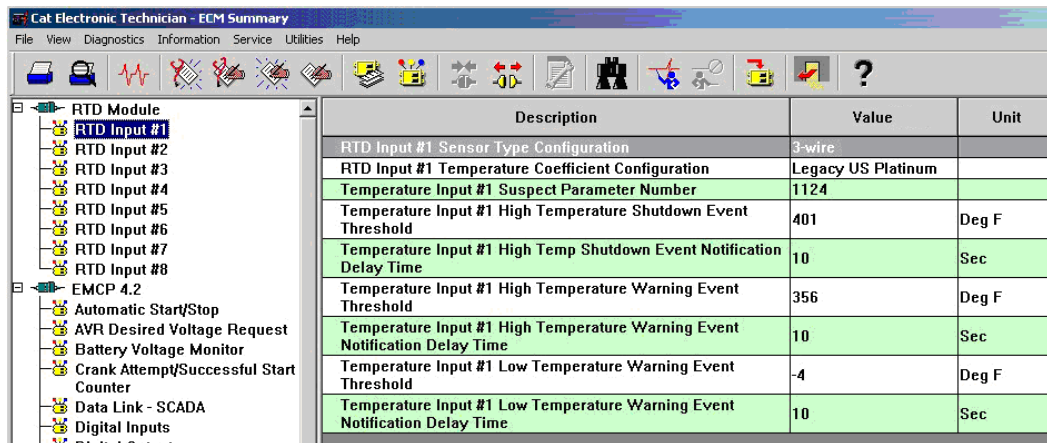

**Figure 48: Cat Service Tool RTD Module Summary Screen**

The service tool configuration tool, accessed by pressing F5 or clicking the configuration tool icon on the toolbar, contains setpoints for configuring the RTD module identification, as well as the RTD inputs.

## CONFIGURING RTD INPUTS

The RTD Input #1 Configuration list of the service tool configuration tool is shown in Figure 49. All eight RTD inputs have identical parameters and options.



Description	Value	Unit
RTD Input #1 Sensor Type Configuration	3-wire	
RTD Input #1 Temperature Coefficient Configuration	Legacy US Platinum	
Temperature Input #1 Suspect Parameter Number	1124	
Temperature Input #1 High Temperature Shutdown Event Threshold	401	Deg F
Temperature Input #1 High Temp Shutdown Event Notification Delay Time	10	Sec
Temperature Input #1 High Temperature Warning Event Threshold	356	Deg F
Temperature Input #1 High Temperature Warning Event Notification Delay Time	10	Sec
Temperature Input #1 Low Temperature Warning Event Threshold	-4	Deg F
Temperature Input #1 Low Temperature Warning Event Notification Delay Time	10	Sec

**Figure 49: Cat Service Tool RTD Module Digital Input Configuration**

The **SENSOR TYPE CONFIGURATION** selects between a 2, 3, or 4 wire configuration. Select the appropriate configuration based on the type of RTD sensor installed. Reference the RTD Module specsheet (LEHE0124) for available Temperature Inputs.

The **TEMPERATURE COEFFICIENT CONFIGURATION** selects between an IEC Platinum, JIS Platinum, Legacy US Platinum, SA MA Platinum or US Platinum type of RTD sensor. Select the appropriate configuration based on the type of RTD sensor installed.

The **SUSPECT PARAMETER NUMBER (SPN)** is a choice between a predetermined list of SPNs that are supported by the RTD module. All of the RTD inputs support the same list of SPNs. To change the SPN, type in the number that corresponds to the desired parameter as shown in Figure 50. See UENR1209 for specific information on what possible SPN values can be used.

The **HIGH TEMPERATURE SHUTDOWN EVENT THRESHOLD** sets the high temperature at which a shutdown event will occur.

The **HIGH TEMPERATURE WARNING EVENT THRESHOLD** sets the high temperature at which a high warning event will occur.

The **LOW TEMPERATURE WARNING EVENT THRESHOLD** sets the low temperature at which a low warning event will occur.

The **EVENT NOTIFICATION DELAY TIME** sets the amount of time the threshold must be reached until the RTD module triggers that particular event on the data link. Each of the delay time options corresponds with a particular event type.

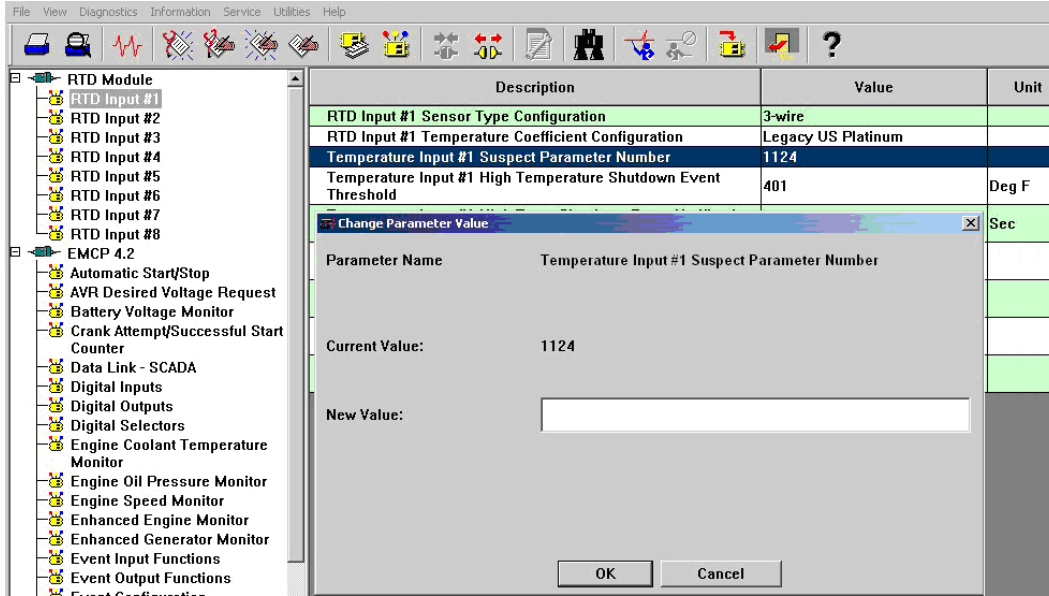

**Figure 50: Cat Service Tool RTD Module Suspect Parameter Number**

**17.5 DISCRETE I/O MODULE (EMCP 4.2 ONLY)**

The EMCP Discrete I/O (DIO) module is designed for mounting on generator sets or remotely, to provide auxiliary switch inputs or relay contact outputs. Up to 4 DIO modules can be used on the EMCP 4.2 Accessory CAN Data Link, given that they are programmed to unique ECU Instance numbers.



**DISCRETE I/O FEATURES**

Reads twelve (12) discrete inputs and sets eight (8) Form C Relay Outputs

Converts between physical I/O and CAN data link commands

System throughput: All channels are scanned in 100 ms

Low-Level input voltage range: 0 to 0.8 V

High-Level input voltage range: 3.75 to 24V

Inputs have internal pull-up resistors

LED to indicate communication network status

Compact size (see mechanical drawing, Figure 51)

## **DISCRETE I/O SPECIFICATIONS**

### **ELECTRICAL SPECIFICATIONS**

Accept 5-32 VDC power (12 or 24VDC nominal)

Over voltage capability is 32 VDC for 1 hour @ 85°C

Resistive Loads rated for 3A@30 VDC

Normally Closed (NC) relay contacts rated for 2A@125 V AC / 2A@30 VDC

Normally Open (NO) relay contacts rated for 2A@125 V AC / 2A@30 VDC

Maximum current draw of 400mA + 50mA per energized relay @ 12VDC

Power supply inputs are protected against transient surges and short circuits and are isolated from I/O

### **ENVIRONMENTAL SPECIFICATIONS**

Encapsulated in a rugged aluminum housing with Deutsch connectors (IP65 rating)

Operating temperature range -40 to 85°C (-40 to 185°F)

The ambient storage temperature range is -50°C to +120°C

It is protected against 95% humidity non-condensing, 30°C to 60°C

Designed to meet relevant European standards for EMI/RFI/Immunity without the use of external filtering

### **NETWORK COMMUNICATIONS INTERFACE**

Operates on the EMCP 4.2 Accessory CAN Data Link

Node address is auto configurable

Optical isolation is provided for the CAN line

Retains current date and time relative to synchronization every 24 hours (or upon boot up) with equipment system time via an explicit command from the EMCP 4 or Service Tool when the GSC is not available; synchronization time is accurate to within 1 second

Includes a watchdog timer to automatically reboot should the microprocessor lock

Module operates normally with loss of communication link, retaining configured values and error codes in non-volatile memory

Configuration and firmware updates are accomplished with the Cat Service Tool over the CAN network

Monitored parameters and alarms are read-only over the network

**DISCRETE I/O WIRING**

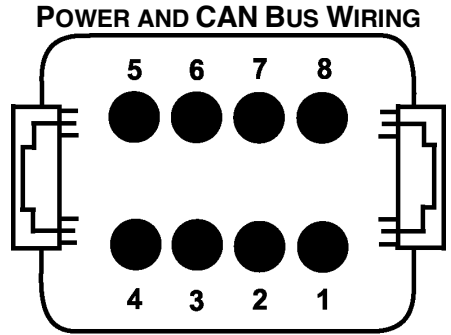

**FRONT VIEW  
MODULE MOUNTED CONNECTOR  
DEUTSCH P/N: DT13-08PA**

- 1 = PWR+    5 = SHIELD
- 2 = CAN-H   6,7,8 = NOT USED
- 3 = CAN-L
- 4 = PWR-

**I/O WIRING TYPICAL CONNECTIONS**

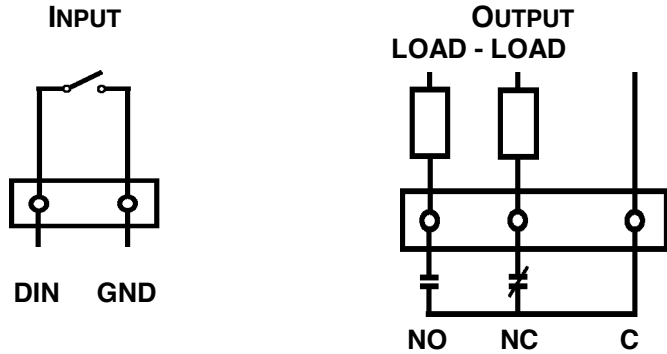

INPUTS	PIN	OUTPUTS	PIN	OUTPUTS	PIN
DIN1	1	NC_1	5	C_6	19
DIN2	11	C_1	6	NO_6	20
DIN3	21	NO_1	7	NC_7	28
DIN4	31	NC_2	15	C_8	29
DIN5	2	C_2	16	NO_7	30
DIN6	12	NO_2	17	NC_8	38
DIN7	22	NC_3	25	C_8	39
DIN8	32	C_3	26	NO_8	40
DIN9	3	NO_3	27		
DIN10	13	NC_4	35		
DIN11	23	C_4	36		
DIN12	33	NO_4	37		
GND	4	NC_5	8		
GND	14	C_5	9		
GND	24	NO_5	10		
GND	34	NC_6	18		

**NO = Normally Open  
NC = Normally Closed  
C = Common**

**Table 28: Discrete I/O**

**Note:** The GND pin is not the package ground, but the Isolated Reference for the module.

**DISCRETE I/O PHYSICAL LAYOUT**

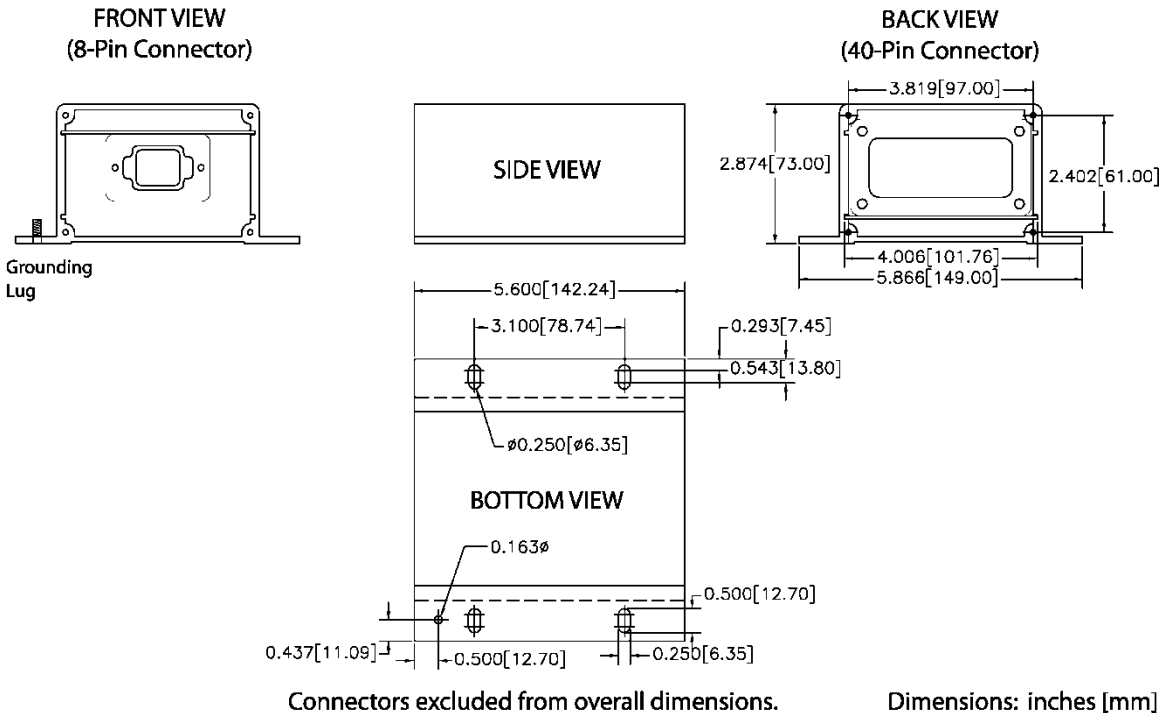
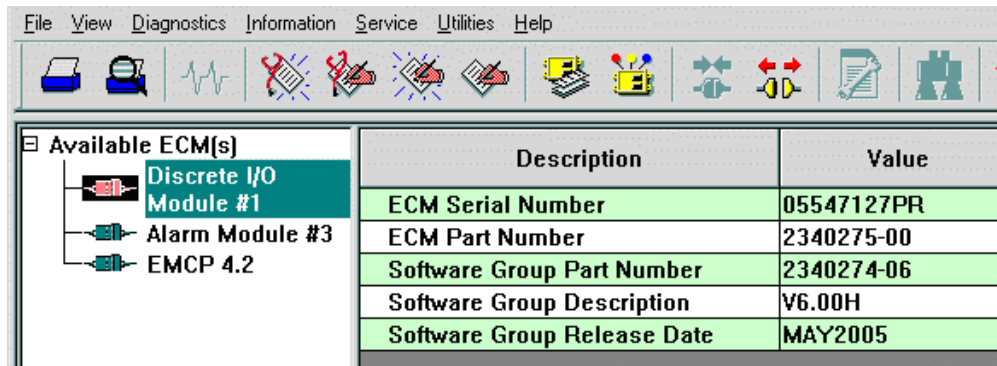

**Figure 51: Thermocouple, RTD, And Discrete I/O Module Physical Layout**

**DISCRETE I/O SOFTWARE CONFIGURATION**

The DIO module is field-programmable using the Cat Service Tool. It is also flash programmable to update software using the Cat Service Tool.

The service tool software must be installed on a Windows PC. The Cat communication adapter must be connected between the PC and the CAN data link on which the target DIO module is connected. (The service tool may be connected to the EMCP 4 Accessory Data Link service connector).



**Figure 52: Cat Service Tool DIO Summary Screen**

When connecting to the DIO, the user will first see the Module Summary screen shown in Figure 52. The service tool configuration tool, accessed by pressing F5 or clicking the configuration tool icon on the toolbar, contains setpoints for configuring the DIO identification, as well as the inputs and outputs.

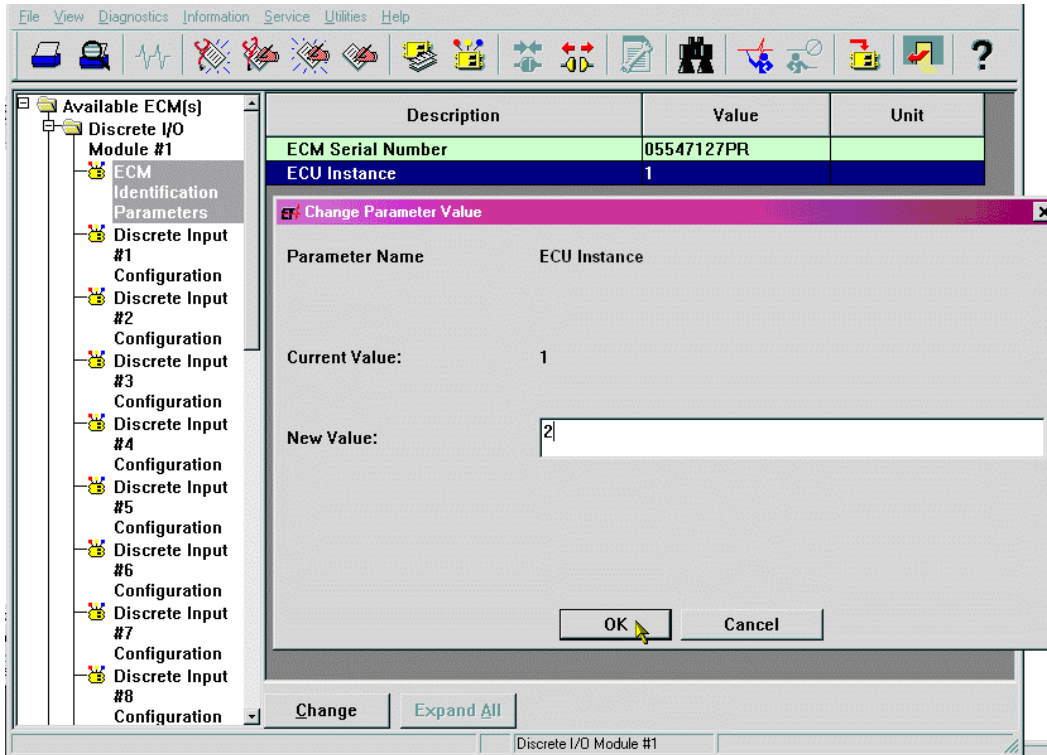

**Figure 53: Cat Service Tool DIO Identification Parameters**

Figure 53 shows the ECM Identification Parameters list. This list shows the ECM serial number (read-only) of the module that is connected, and allows for configuration of the ECU instance.

**Note:** It is important to match a specific module to a certain ECU Instance. The system will not function properly if ECU instances are duplicated.

Upon changing the ECU instance, the Cat Service Tool will automatically disconnect and reconnect to the data link, and the DIO module name should reflect the new ECU instance.

In the example shown in Figure 54, the module was previously named Discrete I/O Module #1, and after the ECU instance is changed to 2 and the service tool reconnects, the name reads Discrete I/O Module #2.

Description	Value
ECM Serial Number	05547127PR
ECM Part Number	2340275-00
Software Group Part Number	2340274-06
Software Group Description	V6.00H
Software Group Release Date	MAY2005

**Figure 54: Cat Service Tool DIO After ECU Instance Change**

## CONFIGURING DIGITAL INPUTS

Figure 55 shows the Discrete Input #1 Configuration list using the service tool configuration tool. All twelve discrete inputs have identical parameters and options.

Description	Value	Unit
Event Input Function #1 Active State Configuration	Low	
Event Input Function #1 Event Notification Delay Time	0	Sec
Event Input Function #1 Suspect Parameter Number	Fuel Level	
Event Input Function #1 Failure Mode Identifier	Low Warning	

Parameter Name	Event Input Function #1 Suspect Parameter Number
Current Value:	Fuel Level
New Value:	<ul style="list-style-type: none"> <li>Air Damper Closed</li> <li>Air Damper Closed</li> <li>Air Filter Differential Pressure</li> <li>Ambient Air Temperature</li> <li>ATS in Emergency Position</li> <li><b>ATS in Normal Position</b></li> <li>Battery Charger Failure</li> <li>Battery Charging System Voltage</li> <li>Battery Voltage</li> </ul>

**Figure 55: Cat Service Tool DIO Digital Input Configuration**

The *active state configuration* determines which state (high or low) triggers the event, and depends on the sensor/switch wiring configuration.

The *event notification delay time* sets the amount of time the input must remain active until the DIO module triggers an event on the data link.

## SUSPECT PARAMETER NUMBER (SPN)

The *suspect parameter number* (SPN) is a choice from a predetermined list of SPNs that are supported by the DIO module. All of the discrete inputs support the same list of SPNs, except Custom Event.

Discrete Input #1, when set to Custom Event, will trigger an event for Custom Event #1. Discrete Input #2, when set to Custom Event, will trigger an event for Custom Event #2; likewise for all twelve discrete inputs.

## FAILURE MODE IDENTIFIER (FMI)

The **FAILURE MODE IDENTIFIER** (FMI) configures what type of failure this event will represent. The technician is free to configure any FMI for any SPN, but discretion must be used. Certain combinations may not be meaningful (i.e. the EMCP 4 may not be configurable to display or trigger a response for certain combinations of SPN and FMI).

For example, a Fuel Level SPN with a Condition Exists FMI is not meaningful; the EMCP 4 can be configured to display or react to only fuel level low or high warnings or shutdowns.

## CONFIGURING RELAY OUTPUTS

The Relay Output #1 Configuration list of the service tool configuration tool is shown in Figure 56. All eight Relay Outputs have identical parameters and options.

The *suspect parameter number* (SPN) is a choice from a predetermined list of SPNs that are supported by the DIO module. If you wish to configure the DIO to trigger an output based on an event on the data link related to a specific SPN, the SPN must be selected here.

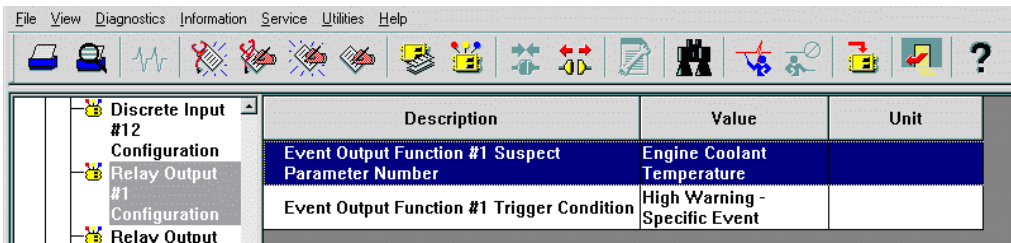

**Figure 56: Cat Service Tool DIO Relay Output Configuration**

The *trigger condition* is a list of conditions that will trigger this output. For the conditions labeled specific event, the relay will be activated upon receiving a category of events (either a single FMI or a set of FMIs) for the SPN selected in the *suspect parameter number* parameter. For the conditions labeled general event, the relay will be activated upon receiving a category of events (either a single FMI or a set of FMIs) for *any* SPN. In this case, the DIO module will ignore the entry in the *suspect parameter number* parameter. If the disabled condition is chosen, the Relay Output will not activate on any condition.

## 18 SCADA (MODBUS) DATA LINK (EMCP 4.2 ONLY)

The **SCADA DATA LINK** or **MODBUS** is supported on the EMCP 4.2.

The EMCP 4.2 has a **SUPERVISORY CONTROL AND DATA ACQUISITION (SCADA)** communications link between the controller and a host device using the **MODBUS** protocol. The host device is able to remotely monitor or control the genset package equipped with the EMCP 4 in much the same way an operator does from the panel.

- The host device connects to the EMCP GSC through an RS-485 SCADA Data Link (Modbus RTU, Half Duplex).
- The data is transmitted in a binary format over the serial connection.
- The host device acts as Modbus Master, and the EMCP 4 acts as the Modbus Slave, also called a **REMOTE TRANSMITTER UNIT (RTU)**.
- The host device initiates all communication, sending commands or requests for information to the EMCP 4.
- The EMCP 4 then takes action based on the query and/or sends a response to the query over Modbus.

Baud rates can be configured on the EMCP 4. Various data rates between 9600 bits/second (baud) and 57,600 bits/second are available. See the SOFTWARE CONFIGURATION Chapter 18.3 for instructions.

**Note:** This port may be required to be used to communicate to switchgear or other monitoring device. Only a single device can be used with this port.

### 18.1 WIRING

**SCADA COMMUNICATION** wires are brought out of the EMCP 4.2 as part of the 70-pin connector. The pins, as designated on the EMCP connector, are shown in Table 29.

SCADA COMMUNICATION WIRES		
Pin #	Name	Description
3	MODBUS –	Optically isolated half-duplex differential (-) for Modbus
4	MODBUS Reference	Half-duplex RS-485 Reference for Modbus
5	MODBUS +	Optically isolated half-duplex differential (+) for Modbus

**Table 29: SCADA Pins on Amp Connector**

**MODBUS DATA TRANSMISSION** over RS-485 is accomplished over a single shielded twisted pair for differential signaling with transmit and receive alternating over the same wire pair (**MODBUS+** and **MODBUS-**). The Reference (**MODBUS REF**) should be connected to the shield, to prevent ground loop currents.

- Figure 57 shows a possible wiring configuration to a RS-485 device.
- Figure 58 shows a possible wiring configuration to a RS-485 to RS-232 converter.

**Note:** See documentation of connected device to verify wiring configuration.

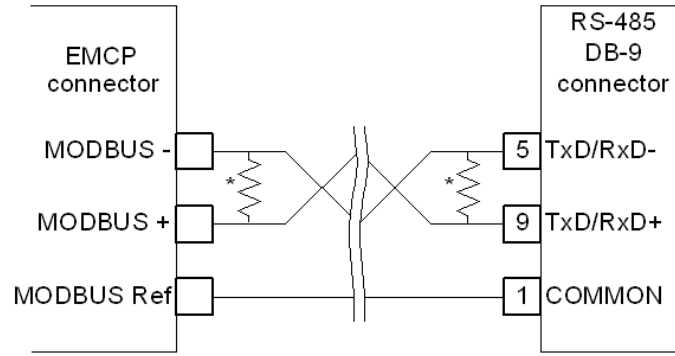

\* - For multipoint network, terminate with 120 ohm resistors at ends of network trunk

**Figure 57: Possible Wiring Configuration To An RS-485 Device**

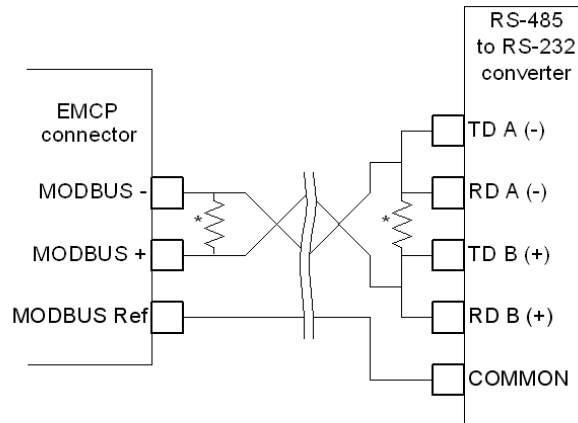

\* - For multipoint network, terminate with 120 ohm resistors at ends of network trunk

**Figure 58: Possible Wiring Configuration To An Rs-485 To RS-232 Converter**

## 18.2 LINE TERMINATION

Both ends of the Modbus lines (or the extreme ends of the trunk, for a multipoint network) should have termination between MODBUS+ (B) and MODBUS- (A).

A 0.5W 150Ω resistor may be adequate.









If line polarization is implemented (see Software Configuration Chapter 18.3), a better choice is a 10 μF capacitor (10V minimum) in series with a 0.25W 120Ω resistor.

**Note:** For more details on setting up a Modbus network over a serial line, please refer to RS-485 specifications or Modbus specifications. See the Software Configuration Chapter 18.3 for instructions on enabling line polarization.

## 18.3 SOFTWARE CONFIGURATION

### CONFIGURING THE SCADA DATA LINK USING THE DISPLAY

The **SCADA DATA LINK** may require software configuration. The configuration parameters are accessible on the EMCP 4 via the following menu options:

<p>At <b>MAIN MENU</b>, scroll <b>DOWN</b>  to <b>CONFIGURE</b></p> <p>Press the <b>OK KEY</b> </p>	<p>MAIN MENU CONTROL <b>CONFIGURE</b></p>
<p>Scroll <b>DOWN</b>  to <b>ALL SETPOINTS</b></p> <p>Press the <b>OK KEY</b> </p>	<p>CONFIGURE INPUTS &amp; OUTPUTS <b>ALL SETPOINTS</b></p>
<p>Scroll <b>DOWN</b>  to <b>NETWORK</b></p> <p>Press the <b>OK KEY</b> </p>	<p>SETPOINTS GEN MONITOR/PROTECT <b>NETWORK</b></p>
<p>Scroll <b>DOWN</b>  to <b>DATA LINK - SCADA</b></p> <p>Press the <b>OK KEY</b> </p>	<p>NETWORK <b>RS-485 SCADA</b></p>
<p>Press the <b>OK KEY</b>  to edit the current <b>SCADA DATA LINK BAUD RATE</b>.</p>	<p>SCADA DATA LINK BAUD RATE <b>9600 BAUD</b></p>

Select the **SCADA DATA LINK BAUD RATE** that you want to program

Press the **OK KEY** 



Scroll **DOWN**  to **SCADA DATA LINK PARITY**

Press the **OK KEY**  to edit the current **SCADA DATA LINK PARITY**.



Select the **SCADA DATA LINK PARITY** that you want to program

Press the **OK KEY** 



Scroll **DOWN**  to **SCADA DATA LINK SLAVE ADDRESS**

Press the **OK KEY**  to highlight the current **SCADA DATA LINK SLAVE ADDRESS**. Select the **SCADA DATA LINK SLAVE ADDRESS** that you want.

Press the **OK KEY** 



Scroll **DOWN**  to **RS-485 BIAS RESISTOR ENABLE STATUS**

Press the **OK KEY**  to edit the current **RS-485 BIAS RESISTOR ENABLE STATUS**.

Select the **RS-485 BIAS RESISTOR ENABLE STATUS** that you want to program

Press the **OK KEY** 

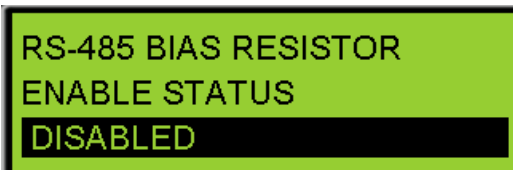

### CONFIGURING THE SCADA DATA LINK USING THE CAT SERVICE TOOL

The EMCP 4 SCADA Data Link can be configured using the Cat Service Tool. To program this Data Link, do the following steps:

1. Connect to the EMCP 4 using the Cat Service Tool as stated in Chapter 4.2.

2. Select Data Link – SCADA on the left.

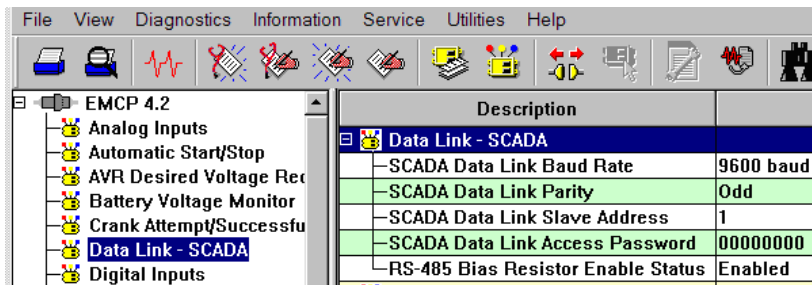

3. Double click SCADA Data Link Baud Rate to change this to the desired value from the drop down menu. Click the OK button to program.

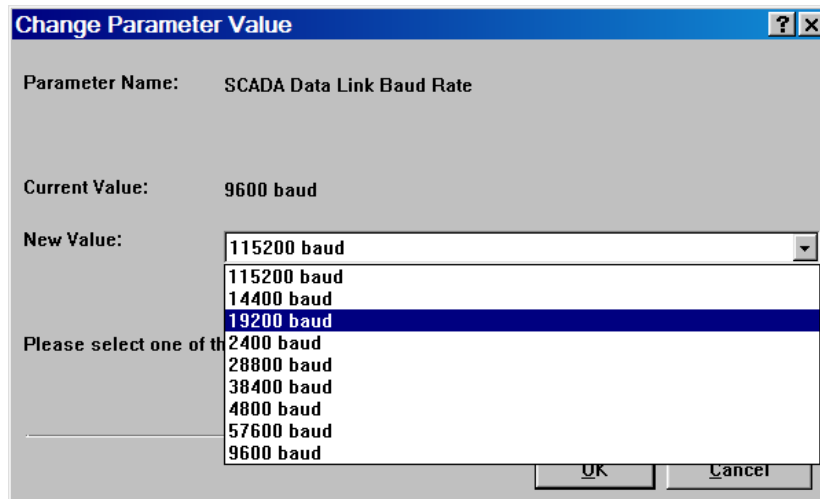

4. Double click SCADA Data Link Parity to change this value from the drop down menu. Click the OK button to program.

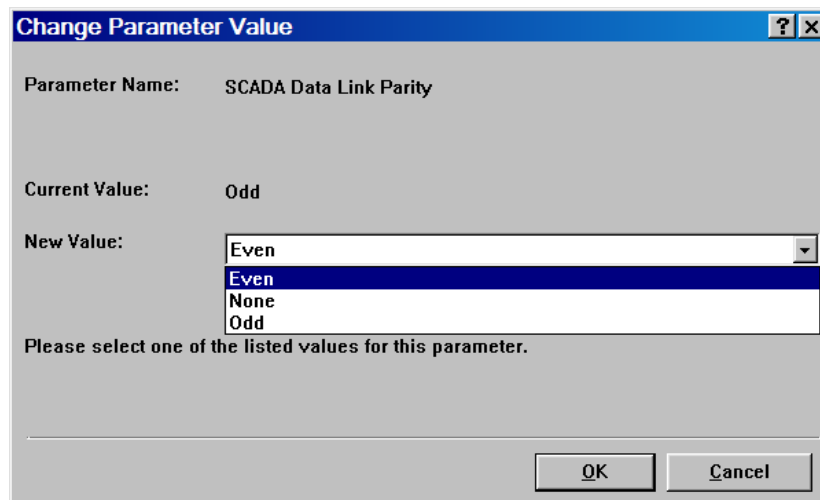

5. Double click SCADA Data Link Slave Address. Change this value by typing a new value. Click the OK button to program.

The screenshot shows a dialog box titled "Change Parameter Value" with a blue header bar containing a help icon and a close button. The dialog has a light gray background. It contains the following text and controls:

- Parameter Name:** SCADA Data Link Slave Address
- Current Value:** 1
- New Value:** A text input field containing the number "2".
- At the bottom right, there are two buttons: "OK" and "Cancel".

6. Double click SCADA Data Link Access Password. Change this value by typing a new value. Click the OK button to program.

The screenshot shows a dialog box titled "Change Parameter Value" with a blue header bar containing a help icon and a close button. The dialog has a light gray background. It contains the following text and controls:

- Parameter Name:** SCADA Data Link Access Password
- Current Value:** 00000000
- New Value:** A text input field containing "24".
- Below the input field, the text reads: "Please enter a text string of 8 characters or less."
- At the bottom right, there are two buttons: "OK" and "Cancel".

7. Double click RS-485 Bias Resistor Enable Status to change this value from the drop down menu. Click the OK button to program.

The screenshot shows a dialog box titled "Change Parameter Value" with a blue header bar containing a help icon and a close button. The dialog has a light gray background. It contains the following text and controls:

- Parameter Name:** RS-485 Bias Resistor Enable Status
- Current Value:** Enabled
- New Value:** A dropdown menu with "Disabled" selected. The dropdown list is open, showing "Disabled" (highlighted in blue) and "Enabled".
- Below the dropdown, the text reads: "Please select one of the listed values for this parameter."
- At the bottom right, there are two buttons: "OK" and "Cancel".

## 19 INSTALLING & UPGRADING SOFTWARE

The EMCP 4 supports field-programming (called flashing) of software for all of the modules. This is done by using the Cat Service Tool software and a Cat Communication Adapter. The Primary Data Link (CAN 1) service connector must be used for modules connected to the Primary Data Link. The Accessory Data Link (CAN 2) service connector must be used for modules connected to the Accessory Data Link. Refer to your generator set package documentation for the location of the service connectors.

To flash the EMCP 4 requires the following hardware and software:

### SOFTWARE AND HARDWARE REQUIRED

- The Cat Service Tool software installed and licensed on a PC
- A Cat Communication Adapter
- A 9-pin Deutsch service connection to the Primary Data Link (CAN 1)
- The new application software flash file for the EMCP 4

In order to install software into the EMCP 4, the genset must be stopped. If upgrading software, it may be important to back up the current configuration (see Chapter 4.2). Flashing application software does not affect the setpoints. However, if a problem occurs during flashing, this backup can be used to quickly configure a replacement module.

Record the current software version information. This is seen in the ECM Summary screen. See Figure 59. This information is useful to obtain the correct flash file if it is desired to return to the previous version of software after flashing.

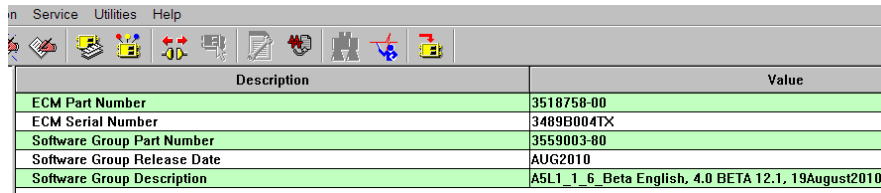

Description	Value
ECM Part Number	3518758-00
ECM Serial Number	3489B004TX
Software Group Part Number	3559003-80
Software Group Release Date	AUG2010
Software Group Description	A5L1_1_6_Beta English, 4.0 BETA 12.1, 19August2010

**Figure 59: ECM Summary Information**

Flashing of modules other than the EMCP 4 follow similar steps as the ones outlined below.

In order to flash an EMCP 4 module, do the following steps:

1. Connect to the EMCP 4 using the Cat Service Tool as stated in Chapter 4.2.
2. Enter the WinFlash Utility by selecting Utilities > WinFlash,

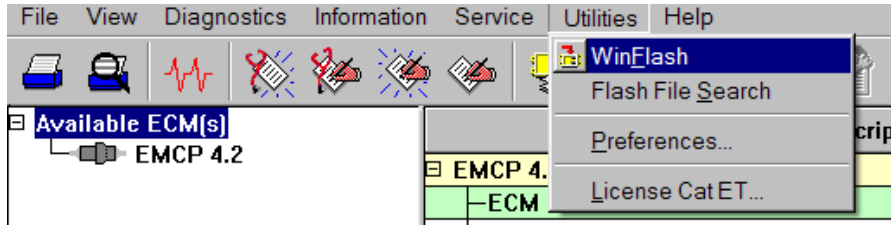

or by clicking the WinFlash Icon.



3. The WinFlash screen will appear.

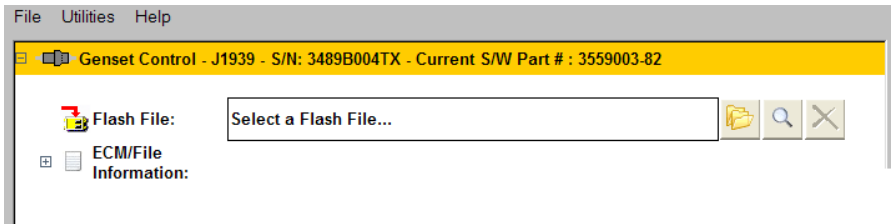

**Note:** If WinFlash does not find all of the modules on the J1939 data link to which it is connected, re-scan the data link by pressing F8 (or selecting File > Update ECM List).

4. Select the Genset Control if multiple modules are listed, then click the “Browse for a File” button on the right hand side.

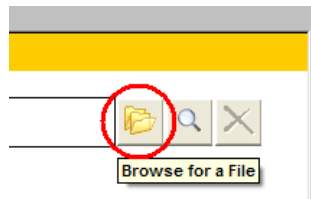

- Browse to the appropriate file and click “Open”.

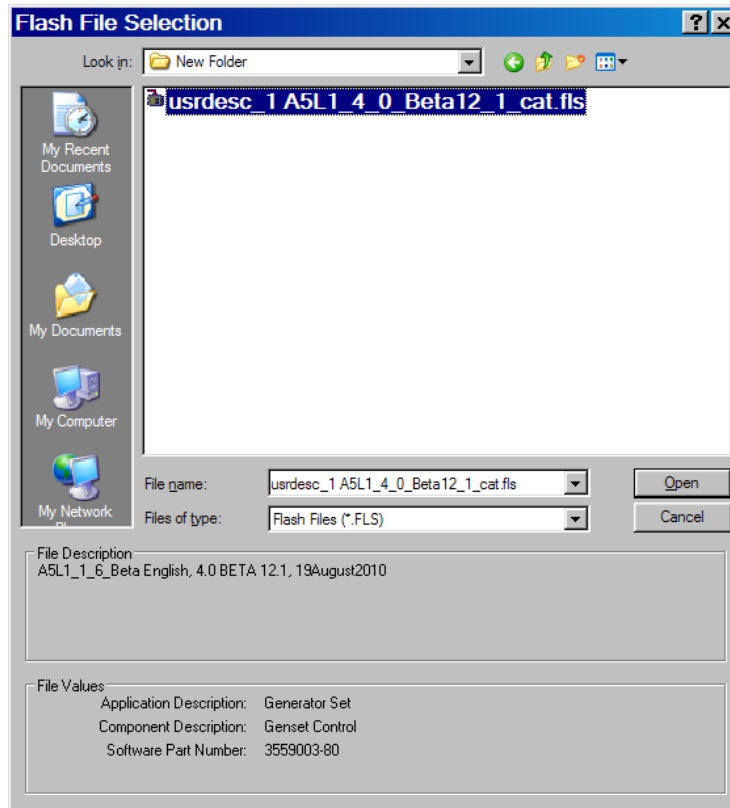

- The new file information will be displayed.

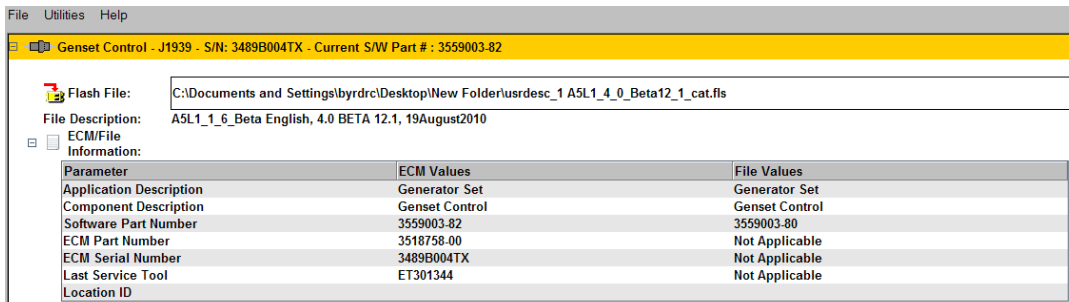

- Click “Begin Flash” in the lower left corner.

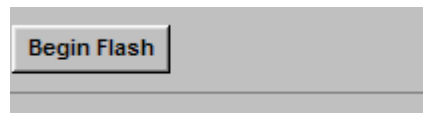

8. A confirmation screen will appear. Click “OK”.

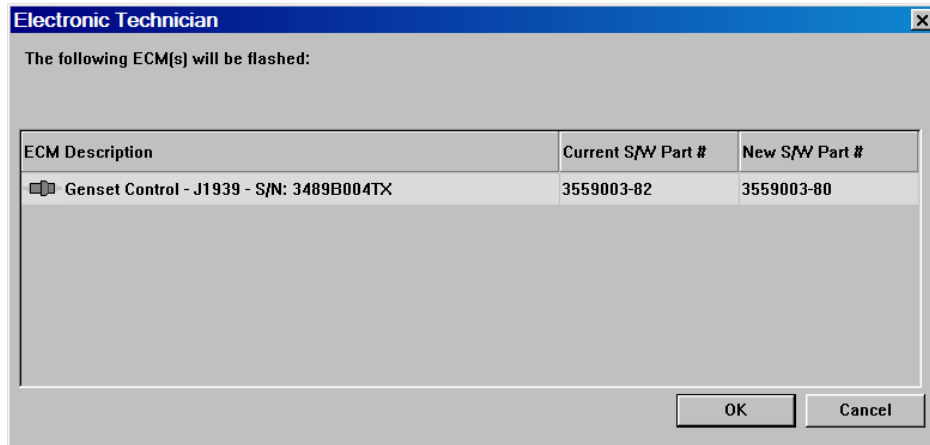

9. A progress meter will show the status of the flash and the EMCP display will show that software installation is occurring.
10. When the flashing process is complete, the ECM that was flashed will reboot. Also, WinFlash will bring up a window giving options for what to do next. This indicates that the software has finished flashing, and is ready to use.

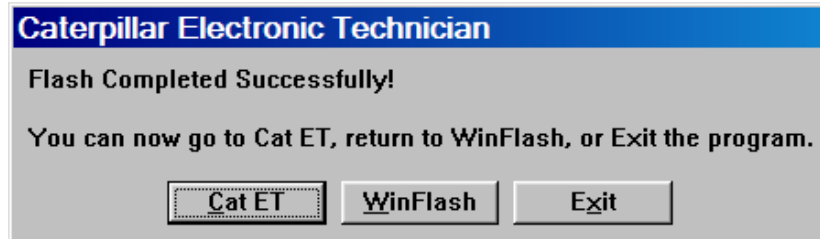

11. On startup, the EMCP 4 shows the software part number. Verify the software part number matches the new application software that was flashed.

## APPENDIX A MENU STRUCTURES

For details on the setpoints available within each submenu, refer to the appropriate section above.

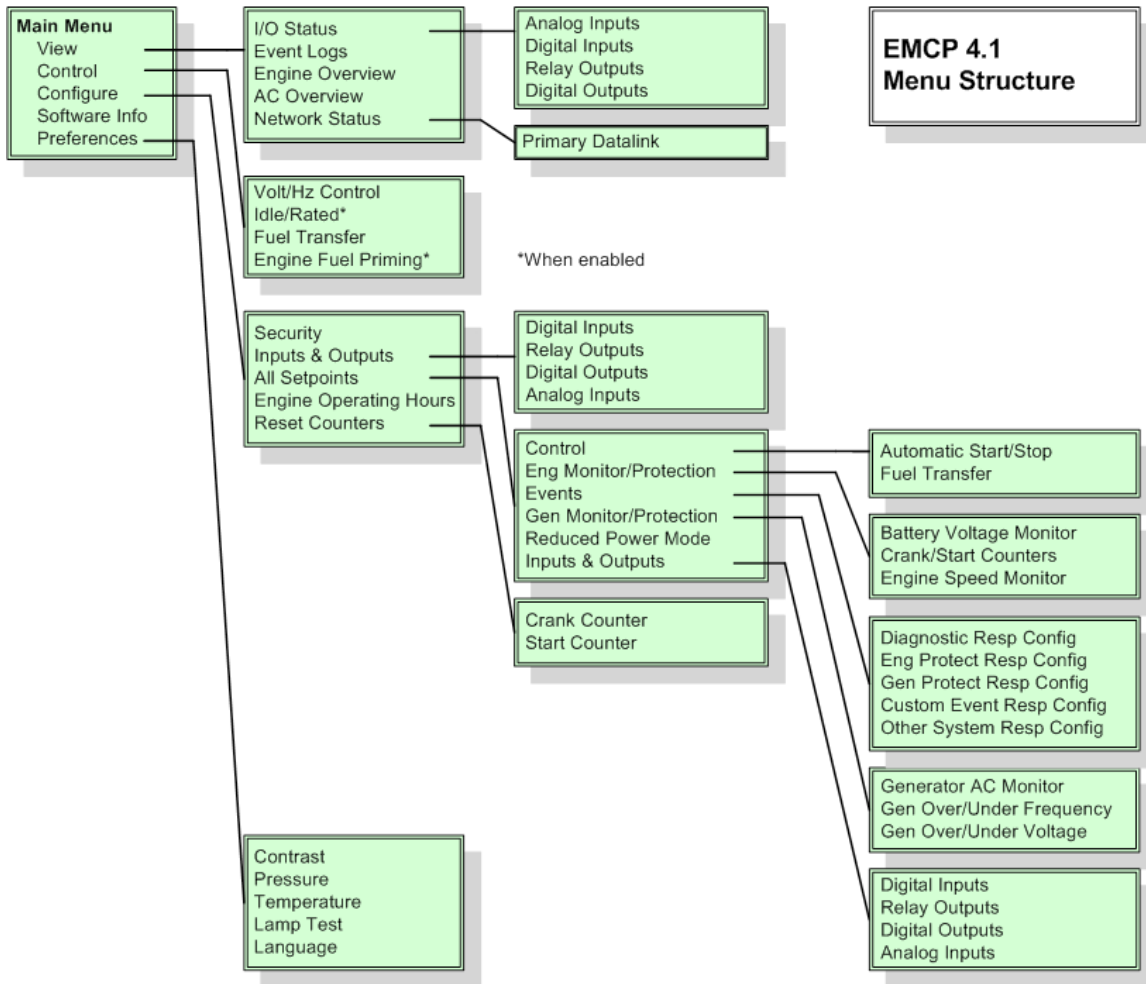

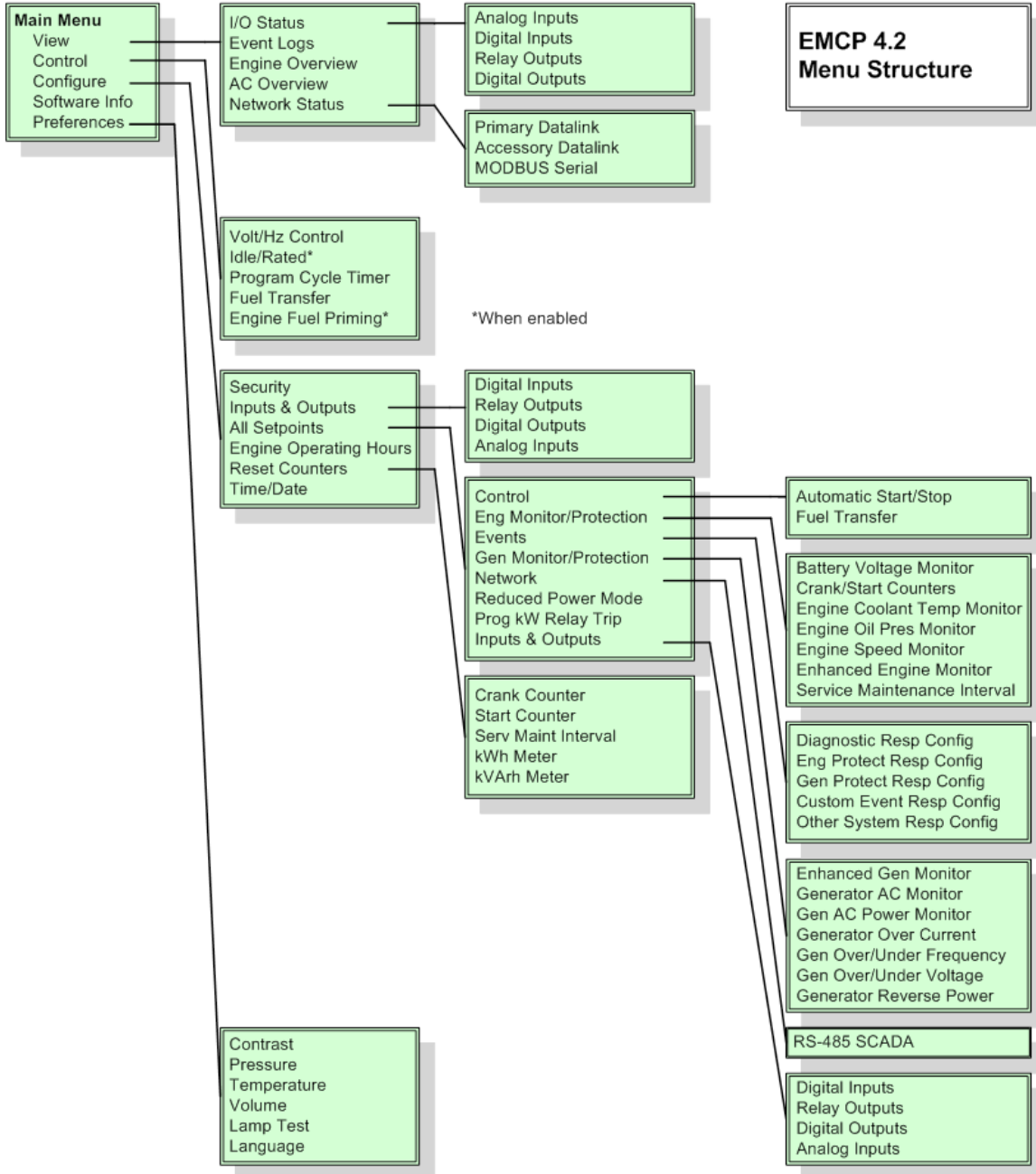

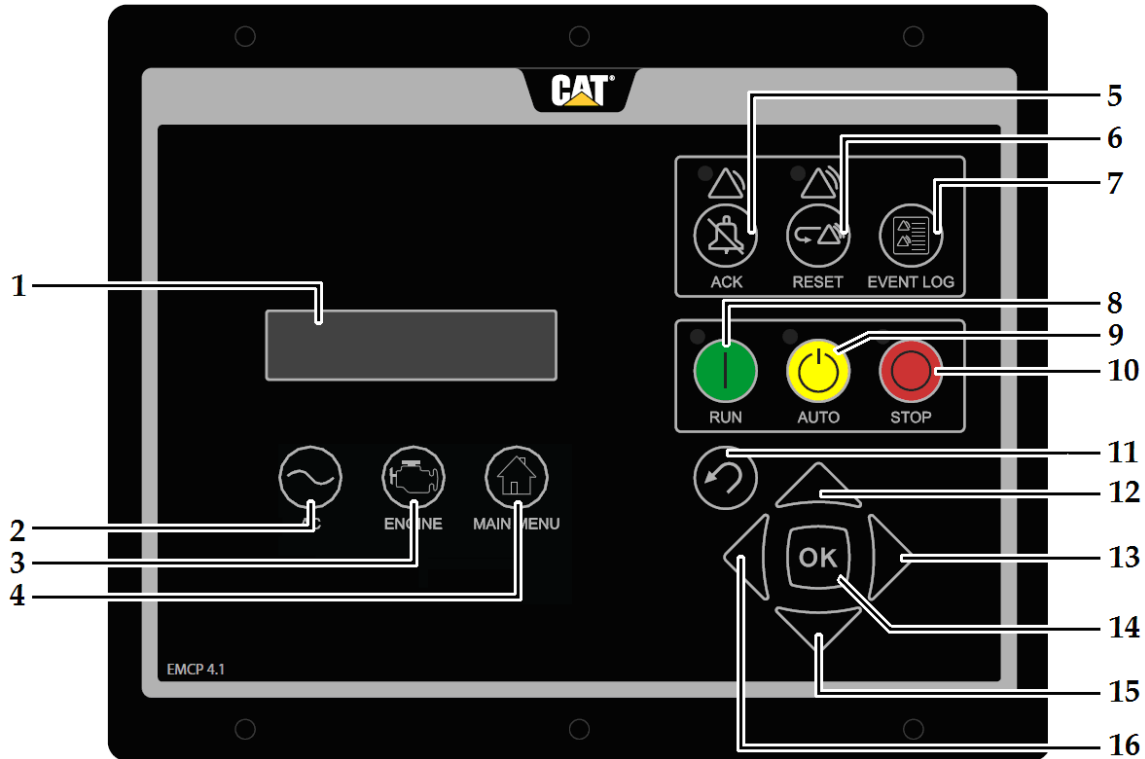
**APPENDIX B EMCP 4 FRONT VIEW & NAVIGATION KEYS****EMCP 4.1 AND 4.2****(1) Display Screen****(2) AC Overview Key****(3) Engine Overview Key****(4) Main Menu Key****(5) Alarm Acknowledge/Silence Key with Amber Warning Lamp****(6) Event Reset Key with Red Shutdown Lamp****(7) Event Log Key****(8) Run Key****(9) Auto Key****(10) Stop Key****(11) Escape Key****(12) Scroll Up Key****(13) Scroll Right Key****(14) OK Key****(15) Scroll Down Key****(16) Scroll Left Key****(1) SCREEN**

Displays various genset information and parameters.

**(2) AC OVERVIEW**

The AC Overview Key will navigate the display to the first screen of AC information. The AC Overview Key information contains various AC parameters that summarize the electrical operation of the generator set.

**(3) ENGINE OVERVIEW**

The Engine Overview Key will navigate the display to the first screen of engine information. The Engine Overview information contains various engine parameters that summarize the operation of the generator set.

- (4) MAIN MENU** The Main Menu key will navigate the display to the main menu directly without having to navigate out of menus.
- (5) ALARM ACKNOWLEDGE / SILENCE** Pressing the Alarm Acknowledge/Silence Key will cause the horn Relay Output to turn off and silence the horn. Pressing the key will also cause any amber or red flashing lights to turn off or to become solid depending on the active status of the alarms. The Alarm Acknowledge/Silence Key may also be configured to send out a global alarm silence on the CAN Data Link which will silence horns on Annunciators, if the CAN Annunciator is configured to respond.
- (6) EVENT RESET** The Event Reset button will clear all inactive fault conditions.
- (7) EVENT LOG** The Event Log button will navigate the display to the list of event logs.
- (8) RUN** Pressing the RUN Key will cause the EMCP to enter the RUN mode.  
**Note:** If a Digital Input is programmed for ECS in Auto, or Stop, and a maintained switch latches that input to make it active, the front panel RUN key will not have any effect.
- (9) AUTO** Pressing the AUTO Key will cause the EMCP to enter the AUTO mode.  
**Note:** If a Digital Input is programmed for ECS in RUN, or Stop, and a maintained switch latches that input to make it active, the front panel AUTO key will not have any effect.
- (10) STOP** Pressing the STOP Key will cause the EMCP to enter the STOP mode.  
**Note:** If a Digital Input is programmed for ECS in Auto, or RUN, and a maintained switch latches that input to make it active, the front panel STOP key will not have any effect.
- (11) ESCAPE** The Escape Key is used during menu navigation in order to navigate up through the menu/sub-menu structure. Each key press causes the user to move backwards/upwards through the navigation menus. The Escape Key is also used to cancel out of data entry screens during setpoint programming. If the Escape Key is pressed during setpoint programming, none of the changes made on screen will be saved to memory. Pressing this key will bring the user back one menu/submenu.
- (12) SCROLL UP** The Scroll Up Key is used to navigate up through the various menus or monitoring screens. The Scroll Up Key is also used during setpoint entry. During numeric data entry the Scroll Up Key is used in order to increment the digits (0-9). If the setpoint requires selection from a list, the Scroll Up Key is used to navigate through the list.
- (13) SCROLL RIGHT** The Scroll Right Key is used during setpoint adjustment. During numeric data entry, the Scroll Right Key is used to choose which digit is being edited. The Scroll Right Key is also used during certain setpoint adjustments to select or deselect a check box. If a box has a check mark inside the box, pressing the Scroll Right Key will cause the check mark to disappear, disabling the function. If the box does not have a check mark inside the box, pressing the Scroll Right Key will cause a check mark to appear, enabling the function.

- (14) OK** The OK Key is used during menu navigation to select menu items in order to navigate forward/downward in the menu/sub-menu structure. The OK Key is also used during setpoint programming in order to save setpoints changes. Pressing the OK Key during setpoint programming causes setpoint changes to be saved to memory.
- (15) SCROLL DOWN** The Down Key is used to navigate down through the various menus or monitoring screens. The Down Key is also used during setpoint entry. During numeric data entry the Down Key is used in order to decrement the digits (0-9). If the setpoint requires selection from a list, the Down Key is used to navigate down through the list.
- (16) SCROLL LEFT** The Scroll Left Key is used during setpoint adjustment. During numeric data entry, the Scroll Left Key is used to choose which digit is being edited. The Scroll Left Key is also used during certain setpoint adjustments to select or deselect a check box. If a box has a check mark inside the box, pressing the Scroll Left Key will cause the check mark to disappear, disabling the function. If the box does not have a check mark inside the box, pressing the Scroll Left Key will cause a check mark to appear, enabling the function.

## **ALARM INDICATORS**

### **AMBER WARNING LIGHT**

The Amber Warning Light is located directly above the Alarm Acknowledge/Silence Key (5). A flashing amber light indicates that there are unacknowledged active warnings. A solid amber light indicates that there are acknowledged warnings active. If there are any active warnings, the amber light will change from flashing yellow to solid amber after the Alarm Acknowledge/Silence Key (5) is pressed. If there are no longer any active warnings, the amber light will turn off after the Alarm Acknowledge/Silence Key (5) is pressed.

### **RED SHUTDOWN LIGHT**

The Red Shutdown Light is located directly above the Event Reset Key (6). A flashing red light indicates that there are unacknowledged active shutdown events. A solid red light indicates that there are acknowledged shutdown events active. If there are any active shutdown events the red light will change from flashing red to solid red after the Alarm Acknowledge/Silence Key (5) is pressed. Any condition that has caused an EMCP shutdown event must be manually reset. If there are no longer any active shutdown events, the red light will turn off.

## *Glossary of Terms*

EMCP 4	Electronic Modular Control Panel 4. This is the Cat generator set control panel, consisting of a generator set control (GSC).
ECM	Electronic Control Module. This is a general term and can refer to any microprocessor-based module that is part of a control system. The engine ECM is an ECM dedicated to the task of engine timing and air/fuel control.
FMI	Failure Mode Indicator. The CAN term for a failure code associated with a particular Suspect Parameter Number. For a complete list of FMI codes, refer to the Systems Operation Troubleshooting Testing and Adjusting guide.
GSC	Generator Set Controller. This is the module responsible for the overall generator protection and control functions. It is the master module on the generator set, interfacing with the user as well as the engine ECM and any other accessory modules.
RMS	A mathematical approach of representing a useful average for varying quantities; this is useful to indicate AC quantities.
RS-232	Recommended Standard 232, maintained by the Electronics Industries Alliance (EIA). Also known as EIA-232.
RS-485	Recommended Standard 485, maintained by the Electronics Industries Alliance (EIA). Also known as EIA-485.
RTU	Remote Transmitter Unit. This term refers to a Slave device in a MODBUS network that merely responds to requests from the Master. The EMCP 4.2 can function as an RTU on a SCADA system via the RS-485 SCADA port.
SCADA	Supervisory Control And Data Acquisition. This term represents any computing system designed to perform high-level control and monitoring over various subsystems. On the EMCP 4, we provide a MODBUS interface to allow any SCADA systems to connect and collect data about the operations of the control and the generator set(s).
SPN	Suspect Parameter Number. The CAN term for any parameter whose data is transmitted over a CAN network, such as the EMCP 4 primary or accessory data link. For a complete list of SPNs supported by the EMCP 4, refer to the Diagnostic Trouble Code List in the Systems Operation Troubleshooting Testing and Adjusting guide.

