

EEG6550 Enhanced Electronic Governor

With Quikset Display

+1-413-233-1888

www.governors-america.com

1 INTRODUCTION

GAC's EEG6550 Series enhanced electronic governor controller is designed to regulate engine speed on diesel and gasoline reciprocating engines. With flexibility, precision, and accurate control of governed speed, the EEG is designed for industrial engine applications from generator sets and mechanical drives, to pumps or compressors. The EEG6550 Series Quikset Display allows its operator to monitor and configure parameters without needing configuration software or a PC.

- Simple LCD User Interface; No potentiometer, No PC required
- 2 Fixed (Rated, Idle) and Variable Speed; Selectable Isochronous, Droop, & Variable Governing
- 5K Ω resistive, 0-5 V or 4-20 mA Variable Speed Input
- Speed Range to 12 KHz (6000 RPM) with Frequency Display
- Configurable Speed Switch
- AUX Input for Synchronization and Load Sharing; Selectable AUX Input Polarity
- Speed Ramping (Any Transient Speed Change)
- Standard GAC AUX Input for Synchronizing and Load Sharing
- J1939 Engine Speed Output
- Fault Protection with Overcurrent Sensing
- Adjustable Starting Fuel Strategy (Black Smoke Reduction)
- Hour Meter and Service Reset Hour Meter
- J1939 Engine Speed Output Variable Speed/Load Input with Service Info and Fault Condition
- Compatible with all GAC actuators except ATB T4 Series, ADB335, and ACB2001.



2 SPECIFICATIONS



PERFORMANCE	
Isochronous Operation	± 0.25 %
Speed Range / Governor	100 Hz -12 kHz (200 - 6000 RPM w/120 tooth flywheel) continuous
Idle Adjust	Up to 1500 RPM
Droop Range	1 - 25 % regulation
Speed Trim	Programmable ± 120 Hz
INPUT / OUTPUT	
Supply	12 - 24 V DC Battery Systems (7.0 to 32.0 V DC)
Polarity	Negative Ground (Case isolated)
Power Consumption	200 mA MAX continuous plus actuator current
Speed Sensor Signal	1.0 - 60.0 V RMS
Actuator Current	8 -10 A Continuous, Momentary 12A MAX. PWM output constant 500 Hz
Load Share/ Synchronizer Input	0 - 10 V DC (5 V nominal, reversed polarity, 145 Hz / V)
Reverse Power Protection	Yes
Transient Voltage Protection	60 V

ENVIRONMENTAL	
Ambient Temperature	-40 to 85 °C [-40 to 185 °F]
Relative Humidity	up to 90 %
All Surface Finishes	Fungus Proof and Corrosion Resistant
PHYSICAL	
Dimension	See Section 3 , Installation
Weight	1.8 lbf (820 gf)
Mounting	Any position, Vertical Preferred
RELIABILITY	
Vibration	7 g, 10 - 2000 Hz
Shock	20 g Peak
Testing	100 % Functional Test
COMPLIANCE / STANDARDS	
Agency	CE, (EN55011, EN50081-2 and EN50082-2)
Communications	SAE J1939 (Optional)

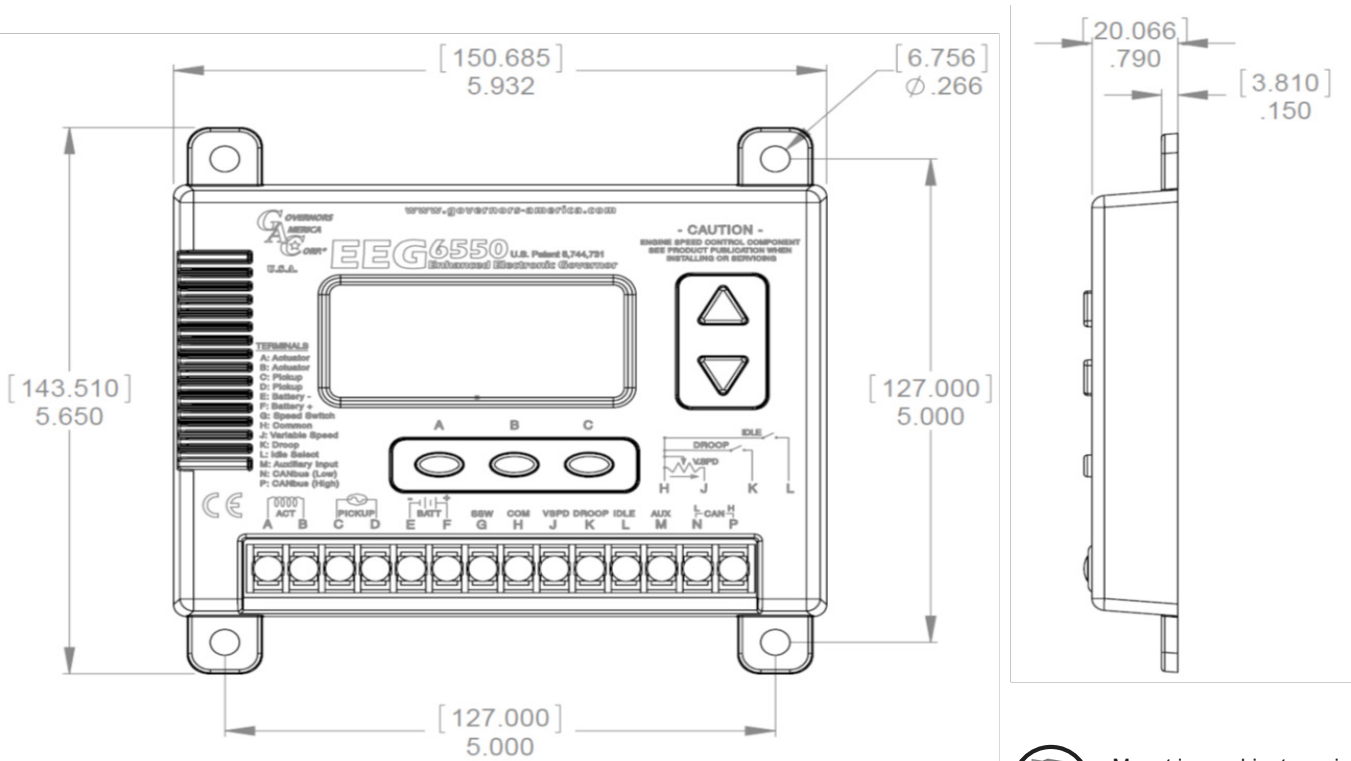
3 INSTALLATION



Dimensions: [mm]
in

-  Mount in a cabinet, engine enclosure, or sealed metal box.
-  Vertical orientation allows for the draining of fluids in moist environments.
-  Avoid Extreme Heat



- Use an overspeed shutdown device, independent of the governor system, to prevent loss of engine control which may cause personal injury or equipment damage.
- Do not rely exclusively on the governor system electric actuator to prevent overspeed. A secondary shutoff device, such as a fuel solenoid must be used.

4 WIRING

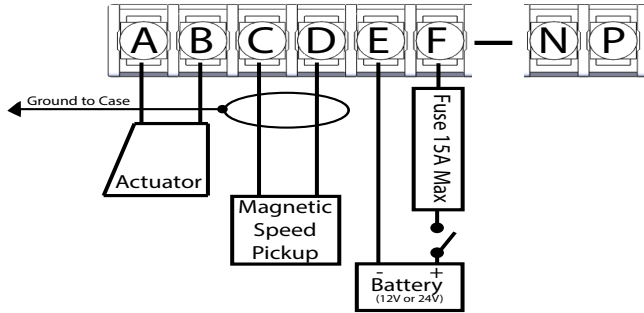

0 - 5 V DC OR 4-20 MA* VARIABLE SPEED INPUT

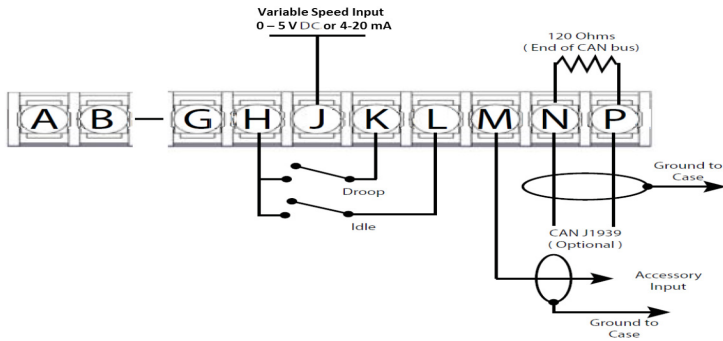

5K Ω RESISTIVE SPEED TRIM POT

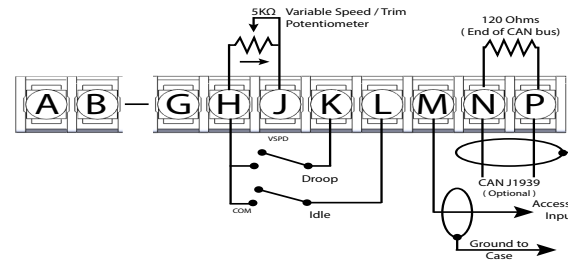

* 4-20mA input requires an external 200 Ω resistor across Terminals H & J



If EEG detects no input from the magnetic pickup, the EEG will set the actuator to 0 V and set the speed to 0 RPM. The display will flash the RPM along with the Warning Indicator. Parameters will be unchangeable.

IMPORTANT

When installing controller be sure there's a good connection between the case of the EEG6550 and the chassis / battery ground.

TERMINAL	DEFINITION	GAUGE / mm ²	NOTES
A	Actuator (+)	16 / 1.31	
B	Actuator (-)	16 / 1.31	
C	Magnetic Pickup (+)	20 / 0.52	* Twisted wires 14 turns per foot. 0.02in (.51mm) gap between sensor and gear teeth.
D	Magnetic Pickup (-)	20 / 0.52	
E	Battery (-)	16 / 1.31	
F	Battery (+)	16 / 1.31	A 15 A fuse must be installed in the positive battery lead to protect against any overload or short circuit
G	Speed Switch (SSW)		Speed switch relay; normally open (nO) or normally closed (nC)
H	Ground Signal	16 / 1.31	Reference for variable speed/trim input & switches
J	Variable Speed Input	20 / 0.52	5K Ω Resistive, 0 - 5 V DC or 4-20 mA. Increasing voltage or resistance of current increases speed.
K	Droop Select	16 / 1.31	Active when connected to Terminal H
L	Idle Select	16 / 1.31	Active when connected to Terminal H
M	Aux Input	20 / 0.52	Load sharing / synchronizing, 5V nominal (0 -10 V DC), configurable polarity
N	CAN L	20 / 0.52	Twist wires 14 turns per foot.
P	CAN H	20 / 0.52	

RECOMMENDATIONS

- Shielded cable should be used for all external connections to the EEG control. One end of each shield, including the speed sensor shield, should be grounded to a single point on the EEG case.
- Case should be grounded

5 DISPLAY & CONTROLS

PARAMETER VALUE

Displays the value of a selected parameter or live running parameter. This area will blink if a system shutdown and restart is required.



PARAMETER UNITS

Displays the units for the parameter (e.g. RPM)



QUICKSET MENU

The quickset menu displays one row of parameters at a time.

COLUMN SELECT BUTTONS



To change displayed parameters:

Tap any

To view a specific parameter value row:

Hold

- For: SPEED Hold button: 1
- For: IDLE Hold button: 2
- For: FUEL LIM Hold button: 3



ADJUST PARAMETER VALUE

Parameter Adjust Up

Increment a Parameter Value:

HOLD and TAP or



Rapidly Increment a Value:

HOLD and HOLD or

Parameter Adjust Down

LOCK / UNLOCK

Once the LOCK parameter on the main menu is enabled (ON), the display can be manually unlocked. See row 2 column 3.

SPEED RAMP V.SPEED LOCKED

Locking/Unlocking the Display

Press and hold both the UP and DOWN arrows simultaneously for 3 seconds to UNLOCK or to LOCK the display.

OVERCURRENT



If the EEG detects an actuator overcurrent it will terminate power to the actuator, the display will flash Actuator Current along with the warning indicator. You must power cycle to restart.

FUEL LIMIT



If the EEG detects that the FUEL LIMIT setting has been exceeded, the display will flash the FUEL LIMIT along with the warning indicator. Parameters will be unchanged.

MENU DETAILS

PRIMARY PARAMETER VALUE

(Blinks if restart required)

PRIMARY PARAMETER UNITS

SECONDARY PARAMETER

ACTUATOR DUTY CYCLE

Example:

- 100 % = 11 Bars
- 90 - 99 % = 10 bars
- 10 - 19 % = 2 bars
- 1 - 95 % = 1 bar
- 0 % = 0 bars

ENGINE SPEED

- Middle bar = set point
- Top bar = Set point + 10 RPM
- Bottom bar = set point - 10 RPM

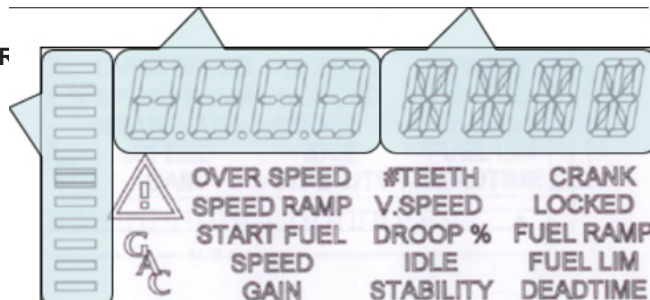

PRIMARY PARAMETER (UNITS)

- Engine Speed (RPM)
- Duty Cycle (%)
- Actuator Current (A)
- Engine Speed (Hz)
- Battery Voltage (V DC)
- Hour Meter (Hrs)
- Service Time (SHR)

SECONDARY PARAMETER

- Actuator Duty Cycle
- Engine Speed relative to set point

Press UP or DOWN arrow to move between the primary and secondary parameters to the next parameter set. The list moves in one direction.

6 FEATURES

TRIM or VARIABLE SPEED OPERATION

Trim Function - Performs finer adjustments (e.g. generator frequency) The resistive input speed function is active when the VSPD (Variable Speed) parameter is OFF (default value is OFF). 5K Ω potentiometer typical.

Variable Speed Function - Operates over a larger RPM range. Variable speed 0 - 5.0 V DC input to Terminal J is active when VSPD (Variable Speed) parameter is ON.

SPECIAL MENU PARAMETER		QUIKSET MENU PARAMETERS	
VSPD	MODE	SPEED	V. SPEED
OFF	Trim (Default)	Application Rated Speed (e.g., 1500 RPM)	Speed Trim (10 = \pm 10 Hz)
ON	Variable Speed	Minimum speed when potentiometer is at lowest resistance (e.g., 1000 RPM)	Maximum Speed when potentiometer is at the highest resistance (e.g., 2000 RPM)



Increasing voltage, resistance or current increases speed.

Variable Speed Input Signal, the EEG6550 controller accepts Resistive, Current and Voltage input signals selected from the VSMD parameter on the Advanced Menu page.

Variable Speed Response to External Voltage Input Variable Speed Parameter (VSPD)- ON, 5 K Potentiometer Between Terminal H & J Configured for 900 to 1800 RPM.

- **Current Input:** (Select CUr) Add an external 200 Ω resistor across Terminals H and J for a 4-20 mA input signal. The SPEED parameter sets the low speed at 4 mA, V.SPEED parameter sets the high speed at 20 mA. If the input current drops below 4 mA, variable speed will be clamped at 0 %. If the input current level exceeds 20 mA, variable speed will be clamped at 100 %. RPM response to current is linear.
- **Voltage Input:** (Select 5dc) voltage to 4.25 V, above 4.25 V the variable speed function will be clamped at 100 %, RPM response to voltage is linear.
- **Resistive Input:** (Select rES) Connect a 5K potentiometer between Terminals H and J. Maximum operating voltage is 5.0 V DC, response to this input is slightly non-linear.

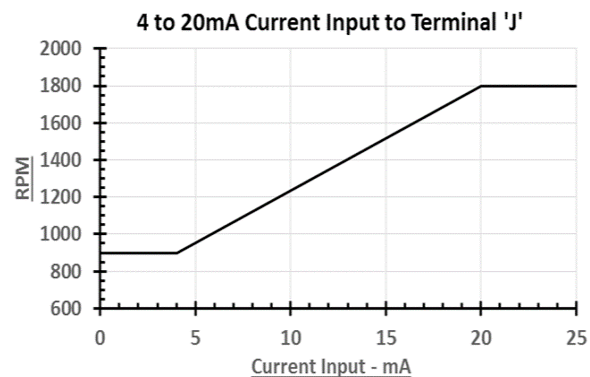
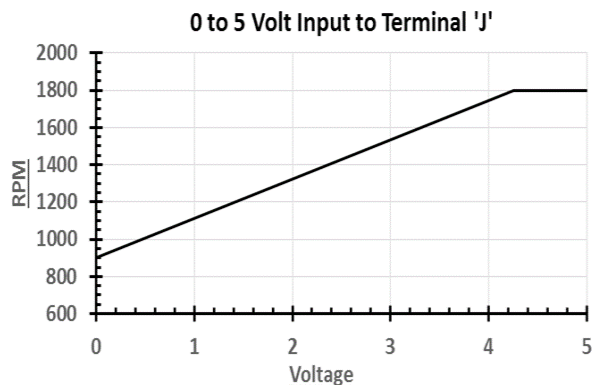

IMPORTANT

Increasing voltage or resistance increases speed.

6 FEATURES (CONTINUED)

POTENTIOMETER, VOLTAGE OR MILLIAMP INPUT TO TERMINAL J

Conversion Formulas:

$$\text{Hertz}_{\text{MAG PICKUP}} = \frac{(\text{RPM} \times \# \text{ Teeth})}{60\text{sec}}$$

$$\text{RPM} = \frac{(\text{Hertz}_{\text{MAG PICKUP}} \times 60\text{sec})}{\# \text{ Teeth}}$$

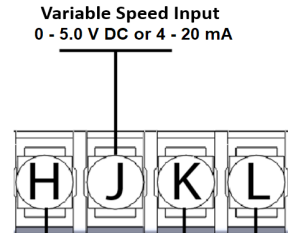
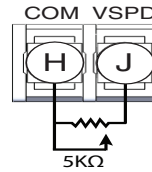

4 - 20 mA input requires an external 200 Ω resistor across Terminals H & J

LIGHT FORCE GOVERNOR

Turning the Light Force Governor, (LFG) feature ON (default is OFF) scales the governor's proportional response (GAIN) for the best resolution when controlling small actuators, including the **ATBT1, ALR, ALN, 100, 103, or 104** series and normally closed Cummins EFC actuators. Turn the LFG feature ON for use with these low current actuators.

The letters LFG display in place of the Primary Parameter Units when adjusting GAIN and STABILITY to indicate the feature is ON. The LFG Feature can only be turned ON or OFF when the engine is not running.

LEAD CIRCUIT

Turning the Lead Circuit (LEAD) ON (default is ON) enables the governor to be more responsive and typically increases the range of GAIN adjustment. Turn Lead Circuit ON when there is slow or moderate hunting at higher GAIN settings.

SPEED ANTICIPATION

Turning the Speed Anticipation feature (**SANT**) ON (default is OFF) reduces RPM recovery time during high load transients, it requires both no load (NLCU) and full load current (FLCU) values to be entered correctly.

IDLE SPEED

The optional external switch must be connected between Terminals H and L. A pressure switch may also be used as a method of enabling. When enabled, IDLE has an independent Gain adjustment.

AUXILIARY INPUT

The Auxiliary (Aux) input, Terminal M, accepts signals from auto synchronizers, load sharing units, and other GAC accessories. Auxiliary Input Polarity (AUXP) set for InC: Increases Speed w/ Increased Voltage or dEC: Decreases Speed w/ Increased Voltage. Aux input is nominally 5.0 V +/-

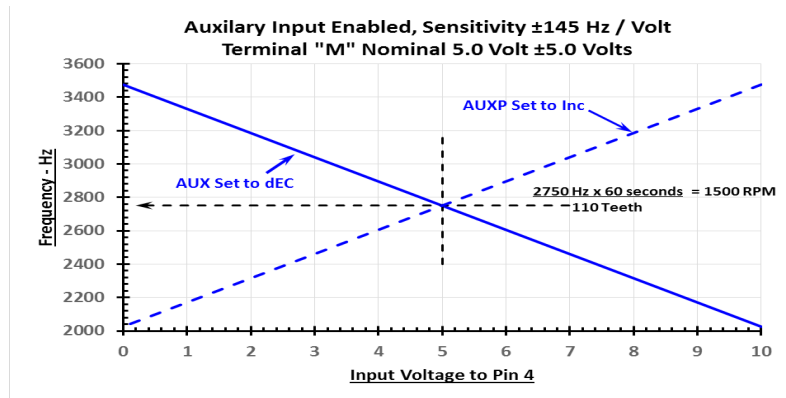

SPEED SWITCH SETTINGS

SSWS is the SPEED SWITCH setting, RPM range is 250 to 4000 RPM. Default setting is 2000 RPM.

SSWP sets the output polarity at either nO (normally open) or nC (normally closed). Default is set at nO.

SSWL sets the speed switch LATCH. With the Latch ON and the speed switch setting exceeded (based on SSWP) the output state is latched until power is cycled. With the Latch setting OFF, the output state of the terminal automatically resets at 0 RPM. Default is ON.

6 FEATURES (CONTINUED)

SERVICE HOUR METER

SRVT sets the hour meter for an alert at the selected service interval. Range of adjustment is 1 to 2000 hours, the default value is 500 hours. If the service time is expired, the displayed number will be '0' or negative.

Disable SRVT by selecting OFF on the Advanced Menu parameter page. Default is Disabled - OFF.

7 ADVANCED PARAMETERS MENU

Display Special Menu Parameters:

Hold ALL 3  until AUX appears in display

Selecting Parameters:

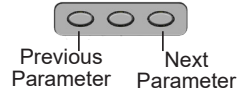

Adjust Parameters:

Increase Parameter 

Decrease Parameter 

Return to Quikset Menu:

Hold ALL 3  for 2 seconds

1. After 3 minutes of no user input, EEG switches to Quikset Menu.
2. Lock is displayed when attempt to change a Read-Only parameter.

ADVANCED MENU PARAMETERS (CONFIGURABLE)

PARAMETER	DEFINITION	RANGE	DEFAULT
AUX	Auxiliary Input Enable 145 Hz/V, 5 V nominal Range: 1-9 V	Off, On	Off
AUXP	Auxiliary Input Polarity V DC: Speed Increases w/ Increased Voltage or dEC: Speed Decreases w/ Increased Voltage	dEC, InC	dEC
VSPD	Variable Speed or Trim Select (On=Variable Speed, Off=Trim)	Off, On	Off
VSMD	Variable Speed Input Signal Resistive / Current / Voltage	rES/ Cur/5dc	5dc
VGLO	Variable speed GAIN, low speed setting	1 - 100	50
VGHI	Variable speed GAIN, high speed setting	1 - 100	50
LFG	Light Force Governor	Off, On	Off
LEAD	Lead Circuit - For Increased Response / Increased GAIN Adjustment	Off, On	ON
SANT	Speed Anticipation Improved Transient Performance	Off, On	Off
NLCU	No Load Current - Amps	0.0 - 9.5	0.5
FLCU	Full Load Current - Amps	0.5 - 10.0	4.0
SSWS	Speed Switch Setting - RPM	100 to 4000	2000
SSWP	Speed Switch: Normally Closed (nC) or Normally Open (nO)	nC / nO	nO
SSWL	Speed Switch Latch On - Resets after Cycling Power, Latch Off Automatically Resets at '0' RPM	On / Off	ON
JADR	CAN J1939 Address	0 - 253	0
SRVT	Service Reset - Hours	1 - 2000	Off

ADVANCED MENU PARAMETERS (READ ONLY)

PARAMETER	DEFINITION
SREV	Software revision number
BID	Software build identifier
AREV	Assembly revision: Identifies board hardware configuration, not software.
FLTH	Highest fault code since power up. Aids in trouble shooting.
DATL	Supplemental data associated with last fault code. Aids in troubleshooting.
FLTL	Last fault code detected. Associated data is DATL and aids in trouble shooting.

JADR parameter identifies J1939 addresses, 0 to 253. Default set to '0'. See Section 13, J1939 CAN Information, for a description of the transmittable data.

Set the following parameters before starting the engine:

#TEETH	Input the Number of Teeth on the Flywheel. This can not be changed while engine is running.
CRANK	Input the Crank Termination (RPM)
SPEED	Input the Fixed Speed of the Engine (RPM)

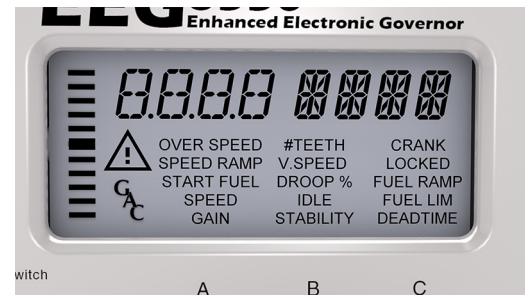

ADJUSTABLE QUIKSET PARAMETERS		
OVER SPEED *	#TEETH	CRANK *
Range: 400 - 6000 RPM Default: 2000 RPM	Range: 60 - 250 Default: 120	Range: 100 - 1000 RPM Default: 400 RPM
RPM to automatically shutoff the actuator	Number of teeth on flywheel	RPM which EEG switches from starting fuel limit to fuel limit
SPEED RAMP	V.SPEED *	LOCKED
Range: 25 - 2000 Default: 300	Range: 0-6000 RPM (vspd) 0-120 Hz (trim) Default: 1800 RPM (vspd) : 0 Hz (trim)	Range: OFF, ON Default: OFF
Rate at which speed changes from idle to set speed and back, or rate change in variable speed mode.	Maximum speed change allowed from trim input	Enables Manual/Auto locking of display. Press and hold UP and DOWN arrows simultaneously for 3 seconds to UNLOCK or LOCK the display.
START FUEL	DROOP%	FUEL RAMP
Range: 0 - 100 % Default: 100 %	Range: 0 - 25.0 % Default: 5.0 %	Range: 1 - 100 % / Sec. Default: 10 %
Initial actuator position at the start of cranking	Droop to apply under maximum load (based on current of actuator)	Actuator position increase in percent per second from cranking to low idle speed, starting from the Start Fuel position
SPEED *	IDLE *	FUEL LIM
Range: 0-6000 RPM (fixed) 0-6000 RPM (droop) Default: 1500 RPM (fixed) 50 RPM (droop)	Range: 150 - 1500 RPM Default: 900 RPM	Range: 0 - 100% Default: 100%
Operating speed of engine	Speed of engine when IDLE input is closed	Maximum actuator percentage allowed
GAIN	STABILITY	DEADTIME
Range: 1 - 100, 100 = Max Gain Default: 50 (rated) : 10 (idle)	Range: 1 - 100, 100 = fastest response Default: 50	Range: LOW, HI Default: HI
Proportional (P) set point of the PID control at operating SPEED and IDLE	Integral (I) set point of the PID control	Derivative (D) set point of the PID control

* 12 KHz MAX

9

ADJUSTING FOR STABILITY

Once the engine is running at operating speed and at no load, the following controller performance adjustments can be made to increase engine stability.

GAIN - RATED SPEED & IDLE SPEED

The EEG6550 is equipped with two separate gains, one for rated speed, the other for idle speed. Both are set using the GAIN setting on the Quikset Menu.

GAIN TYPE	ADJUSTMENT PROCEDURE	
RATED SPEED	1.	Selected when IDLE input is disconnected.
IDLE SPEED	1.	Connect the idle input to ground.
	2.	Change GAIN value.
	3.	Disconnect Idle input from ground to switch back to rated. Idle icon will blink.

QUIKSET MENU		
PARAMETER	ADJUSTMENT PROCEDURE	
A.	GAIN	<ol style="list-style-type: none"> Increase this parameter until instability develops. Then, gradually decrease this parameter until stability returns. Finally, decrease this parameter one increment further to ensure stable performance. If instability persists, adjust the next parameter.
B.	STABILITY	<ol style="list-style-type: none"> Follow the same adjustment procedure as the GAIN parameter. If instability persists, adjust the next parameter.
C.	DEADTIME	<ol style="list-style-type: none"> If fast instability occurs, switch DEADTIME to low and repeat steps A & B.

NOTE Normally adjustments made at no load achieve satisfactory performance. For further performance see Section 14, System Troubleshooting.

10

ADJUSTING FOR DROOP

After the initial set up is completed and the # of Teeth, Crank Termination Speed and Rated Speed are set, position the external switch connecting Terminals H and K on to activate the DROOP mode following these sequence steps.

- On the EEG, press and hold all three buttons simultaneously for two seconds to switch to Advanced Menu.
- Confirm that the VSPD (Variable Speed / Fixed Speed Control) is OFF. Default position is off.
- Confirm that the LEAD circuit is OFF. Default position is on.
- Set the NLCU (No Load Current) to the measured / displayed current value when operating at no load rated speed (default value is 0.5 amps.)
- Set the FLCU (Full Load Current) to the measured / displayed current value when operating at full load rated speed (default value is 4.0 amps.)
- Return to the Main Menu: Press and hold all three buttons simultaneously for two seconds to switch to the Main Menu.
- Select and set DROOP to the desired percentage.
- Change the Speed parameter, this now displays DROOP OFFSET. This sets the RPM, above operating speed; this is used when DROOP is enabled. This is an offset value.

EXAMPLE

1500 RPM operating speed x 0.05 (5.0% droop) = 75 RPM Input 75 RPM, this is the offset value.

11

VARIABLE SPEED GAIN

When in variable speed operation, the PID will use the VGLO (Variable Gain Low) and VGHI (Variable Gain High) in place of the GAIN parameter on the main screen. These variable speed Gain values are used to interpolate between the low and high points in parallel with speed to provide gain ramping as speed is adjusted.

NOTE If the GAIN on the main menu is changed while in variable speed mode, the unit will flash LOCK to indicate the parameter is not available in that mode.

12 FAULT CODES

ADVANCED MENU PARAMETERS (CONFIGURABLE)			
CODE	CAUSE	EFFECT	CUSTOMER ACTION
1	Actuator over current (continuous)	Actuator turned off for 30 s.	Check actuator wiring.
2	Loss of speed signal (inc/dec in speed by more than 64 Hz in 4 ms, 16 K Hz/s)	WARNING indicator blinks then system shutdown	Check speed pickup.
3	Over speed (speed exceeds OVER SPEED setting for 12 ms)	WARNING and OVER SPEED indicators blink then system shutdown.	Check fuel system as well as OVER SPEED, SPEED, and V.SPEED
203	Variable Speed settings are reversed. V.SPEED is lower than SPEED.	WARNING indicator blinks, speed set to V.SPEED setting, variable speed input unresponsive.	Flip V.SPEED and SPEED settings.
206	No potentiometer/signal detected on variable speed input when VSPD enabled.	WARNING indicator blinks, speed set to SPEED setting.	Check potentiometer wiring.
241	New software loaded. Configuration not compatible.	Default configuration used.	Reset configuration.
251	Software loaded on incompatible hardware.	WARNING indicator blinks then System shutdown.	Return unit to GAC
307	FLCU / NLCU Setting invalid	Load calculation done with 0.5 & 4.0 A values	Adjust NLCU / FLCU

IMPORTANT

For all other codes, note the condition and contact GAC. The WARNING indicator will blink and failures will cause a system shut down.

13 J1939 CAN INFO

Data transmitted on the J1939 Bus:

PGN	DEFINITION	NOTES
61443	Variable Speed (SPN91) / Load Input (SPN92)	0 - 100 %
61444	Engine Speed (SPN190)	0 - 100 %
64914	Operating State (SPN3543) / Shutdown Request (SPN3607)	Stopped, Starting, Running, Post-Run
65216	Service Information (SPN916)	Service Time, +/- 20,000 Hours
65252	Fault Condition (SPN2814)	Engine Alarm Output Command Status, No Shutdown Requested (SPN1110)
65253	Engine Run Time (SPN247)	0 - 65,500 Hours
65271	Battery Voltage (SPN158)	0 - 64.0 V DC

SYSTEM INOPERATIVE

If the engine governing system does not function, the fault may be determined by performing the voltage tests described in Steps 1 through 3. Positive (+) and negative (-) refer to meter polarity. Should normal values be indicated during troubleshooting steps, then the fault may be with the actuator or the wiring to the actuator. Tests are performed with battery power on and the engine off, except where noted. See your actuators installation manual for testing procedures for that actuator.

STEP	WIRES	NORMAL READING	PROBABLE CAUSE OF ABNORMAL READING
1	F(+) & E(-)	Battery Supply Voltage (12 or 24 V DC)	<ol style="list-style-type: none"> DC battery power not connected. Check for blown fuse Low battery voltage Wiring error
2	C & D	1.0 V AC RMS min. While Cranking	<ol style="list-style-type: none"> Gap between speed sensor and gear teeth too great Improper or defective wiring to the speed sensor Resistance between Terminals D and C should be 130 to 1200 Ω. Defective speed sensor.
3	F(+) & A(-)	1.0 - 2.0 V DC While Cranking	<ol style="list-style-type: none"> SPEED or IDLE parameter set incorrectly CRANK or START FUEL set incorrectly Short/open in actuator wiring Defective speed control Defective actuator, see your actuator troubleshooting documentation.

INSTABILITY

INSTABILITY	SYMPTOM	PROBABLE CAUSE OF ABNORMAL READING
Fast Periodic	The engine seems to jitter with a 3Hz or faster irregularity of speed.	<ol style="list-style-type: none"> Readjust the GAIN and STABILITY for optimum control. In extreme cases, change the DEADTIME parameter.
Slow Periodic	Speed irregularity below 3Hz. (Sometimes severe)	<ol style="list-style-type: none"> Check fuel system linkage during engine operation for: <ol style="list-style-type: none"> binding high friction poor linkage DEADTIME Parameter set too high.
Non-Periodic	Erratic Engine Behavior	<ol style="list-style-type: none"> Increasing the GAIN should reduce the instability but not totally correct it. If this is the case, there is most likely a problem with the engine itself. Check for: <ol style="list-style-type: none"> engine mis-firings an erratic fuel system load changes on the generator set voltage regulator.

UNSATISFACTORY PERFORMANCE

SYMPTOM	NORMAL READING	PROBABLE CAUSE OF ABNORMAL READING
Engine Over Speeds	<ol style="list-style-type: none"> Do Not Crank. Apply DC power to the governor system. 	<ol style="list-style-type: none"> If the actuator is at minimum fuel position and there exists an erroneous speed signal, then check speed sensor.
	<ol style="list-style-type: none"> Manually hold the engine at the desired running speed. Measure the DC voltage between Terminals A(-) & F(+) on the speed control unit. 	<ol style="list-style-type: none"> If the voltage reading is 1.0 to 2.0 V DC: <ol style="list-style-type: none"> SPEED parameter set above desired speed Defective speed control unit If voltage reading is > 2.0 V DC then check for: <ol style="list-style-type: none"> actuator binding linkage binding If the voltage reading is below 1.0 V DC then defective speed control unit
	<ol style="list-style-type: none"> Check #TEETH parameter. 	<ol style="list-style-type: none"> Incorrect tooth count entered.
Over Speed shuts down engine before or after running speed is reached	<ol style="list-style-type: none"> Examine the SPEED and OVER SPEED operating parameters for the engine 	<ol style="list-style-type: none"> SPEED parameter set too high. OVER SPEED set too close to SPEED. Check SPEED RAMP parameter. Check if VSPD is ON by mistake Check if AUX is ON by mistake Actuator or linkage binding. Speed Control unit defective. Gain too low.
Over Speed shuts down engine before running speed is reached	<ol style="list-style-type: none"> Check resistance between Terminals C&D. Should be 130 to 1200 Ω. See specific Magnetic Pick-up data for resistance. 	<ol style="list-style-type: none"> OVER SPEED set too low If the speed sensor signal is erroneous, then check the wiring.

14 SYSTEM TROUBLESHOOTING (CONTINUED)

UNSATISFACTORY PERFORMANCE

SYMPTOM	NORMAL READING	PROBABLE CAUSE OF ABNORMAL READING
Actuator does not energize fully	1. Measure the voltage at the battery while cranking.	1. If the voltage is less than: a. 7 V for a 12 V system, or b. 14 V for a 24 V system, Then: 1. Check wiring 2. Check circuit protection/relay 3. Check charging system 4. Check battery
	2. Momentarily connect Terminals A and F. The actuator should move to the full fuel position.	1. Actuator or battery wiring in error 2. Actuator or linkage binding 3. Defective actuator 4. Fuse open. Check for short in actuator or harness. 5. Check START FUEL and CRANK
Engine remains below desired governed speed	1. Measure the actuator output, Terminals A & B, while running under EEG control.	1. If voltage measurement is within 2 V DC of the battery supply voltage level, then fuel control is restricted from reaching full fuel position, possibly due to mechanical governor, carburetor spring, or linkage interference. 2. Check SPEED, IDLE, GAIN, START FUEL, and CRANK

DISPLAY ACCESS - LOCK / UNLOCK

To lock or unlock the display, press and hold both the UP and DOWN arrows simultaneously for 3 seconds.



If unsuccessful in solving instability, contact [GAC for assistance](mailto:GAC@governors-america.com).
GAC@governors-america.com or call: 1-413-233-1888



EEG6550 Technical Assistance Worksheet

Please provide the following information so we assist you with timely, technical recommendations:

Date: _____

Company Name: _____

Contact Info: E-Mail Address: _____

Phone Number: _____

Reported Problem: _____

Engine Make, Model & Application: _____

Controller Model and Serial Number: _____

Actuator Model and Serial Number: _____

EEG6550 CONTROLLER SETTINGS		
Parameter	Factory Settings	Customer Settings
# of Teeth	120	
Crank	400 RPM	
Speed Ramp	300 RPM/s	
Overspeed	2000 RPM	
V.Speed	1800 RPM (VSPD) 0 Hz (Trim)	
Start Fuel %	100	
Droop %	5.0	
Fuel Ramp %	10	
Speed	1500 RPM	
Idle	900 RPM	
Fuel Limit %	100	
Gain	50 (Rated) 10 (Idle)	
Stability	50	
Deadtime	HI	

ELECTRICAL CHECKS		
F(+) & E (-)	12 or 24 V DC	
C & D	1.0 V AC RMS MIN at Cranking	
F (+) & A (-)	1.0 to 2.0 V DC While Cranking	

ADVANCED SETTINGS		
Parameter	Factory Settings	Customer Settings
AUX	Off	
AUXP	dEC	
VSPD	Off	
VSMD	5dc	
VGLO	50	
VGHI	50	
LFG	Off	
LEAD	ON	
SANT	Off	
NLCU	0.5	
FLCU	4.0	
SSWS	2000 RPM	
SSWP	nO	
SSWL	ON	
JADR	0	
SRVT	OFF	
FLTL	-----	
DATL	-----	

ADVANCED MENU PARAMETERS (READ ONLY)		
Parameter	Factory Settings	Software Revision Number
SREV	-----	